

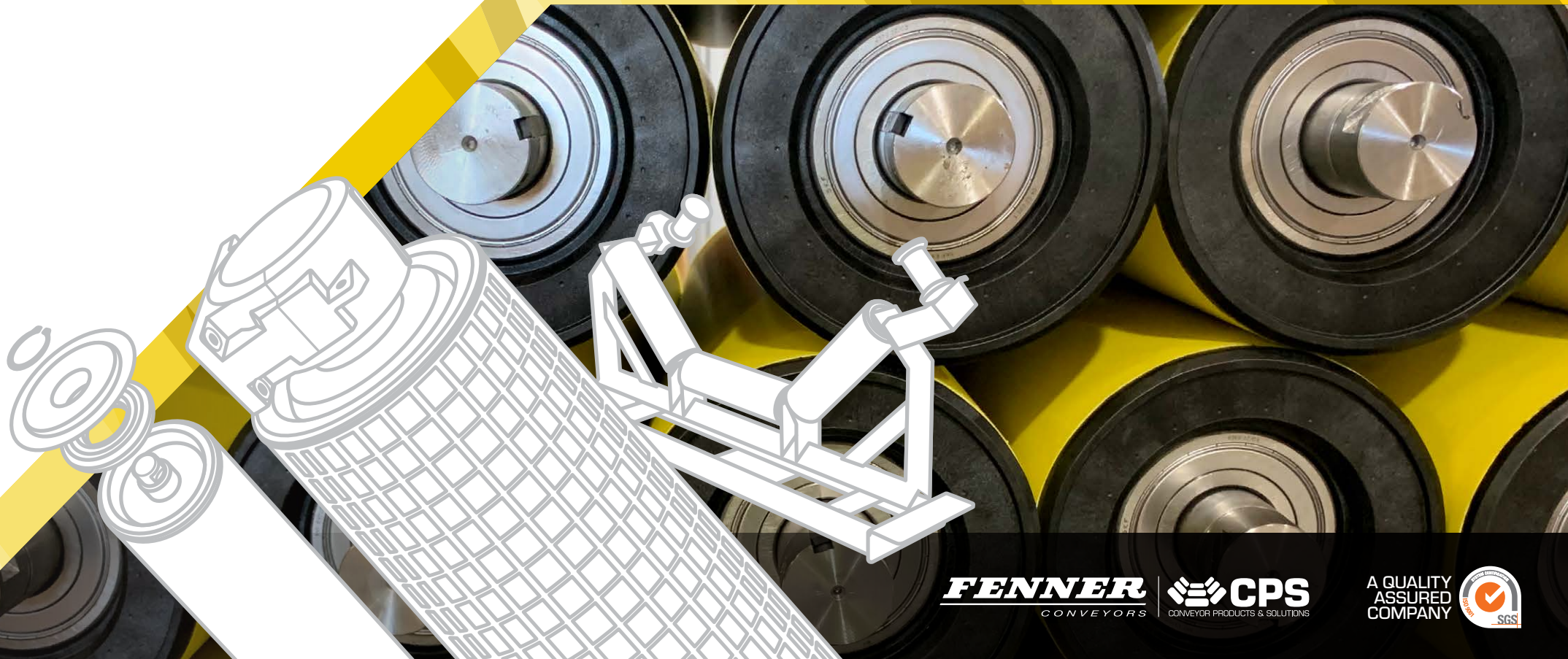

QUICK PRODUCT GUIDE



FENNER
CONVEYORS



A QUALITY
ASSURED
COMPANY



A Better Way Forward

Conveyor Products and Solutions (CPS) is a proud leader in innovation and technology in the conveyor industry. CPS is an Australian manufacturer specialising in high quality conveyor rollers, idlers, pulleys and associated bulk materials handling components. The company is committed to excellence in both quality in the manufacturing process and service; regardless of customer location or order quantity by ensuring we deliver right, in full and on time.



In 2022 Fenner Conveyors acquired CPS. The acquisition strengthened the Fenner Conveyors Group's capability to provide Australian and global customers with a comprehensive end-to-end solution for all conveyor related requirements. Combining our businesses aligns with our commitment to quality local manufacturing and comprehensive customer service and support. It also gives CPS broader reach into a greater skill-set and resources to truly provide complete conveyor solutions.

Ongoing investment in automation with a dedicated focus on innovation and the continuous improvement of our manufacturing processes, ensure CPS conveyor products are of consistent quality, fit-for-purpose and meet the requirements of our customers.

We are committed to producing high quality products that deliver sustainable value to our clients. We are also committed to leading the industry with our engineering innovation, building long term relationships and delivering cost-effective solutions that meet the requirements of our customers globally.



Engineering Capabilities, **Innovations & Solutions**

The Engineering department at CPS is responsible for the continuous improvement of our products and manufacturing systems. Our team utilises the latest computer-aided design and simulation software to assist in ensuring client needs are consistently exceeded. Engineering resources have been invested in automation systems, maximising our capacity and guaranteeing our products are quick to market while cost effective. The team aids our clients with technical support and can also provide in-depth on-site assistance. Extensive R&D and roller failure analysis is carried out in our dedicated CPS test centre.

As a solutions specialist, we offer the following services:

- Technical and service personnel available for on-site analysis, inspections and custom solutions for key problem areas.
- Design, modification, analysis and optimisation of idler components.
- 3D CAD drafting software to create detailed in-situ models.
- Reduction of downtime through innovative and practical engineering.
- Provide long term solutions, reducing the Total Cost of Ownership (TCO).
- Conveyor design review analysis, engineering services (on-site and off-site) and operation and maintenance consultancy services.

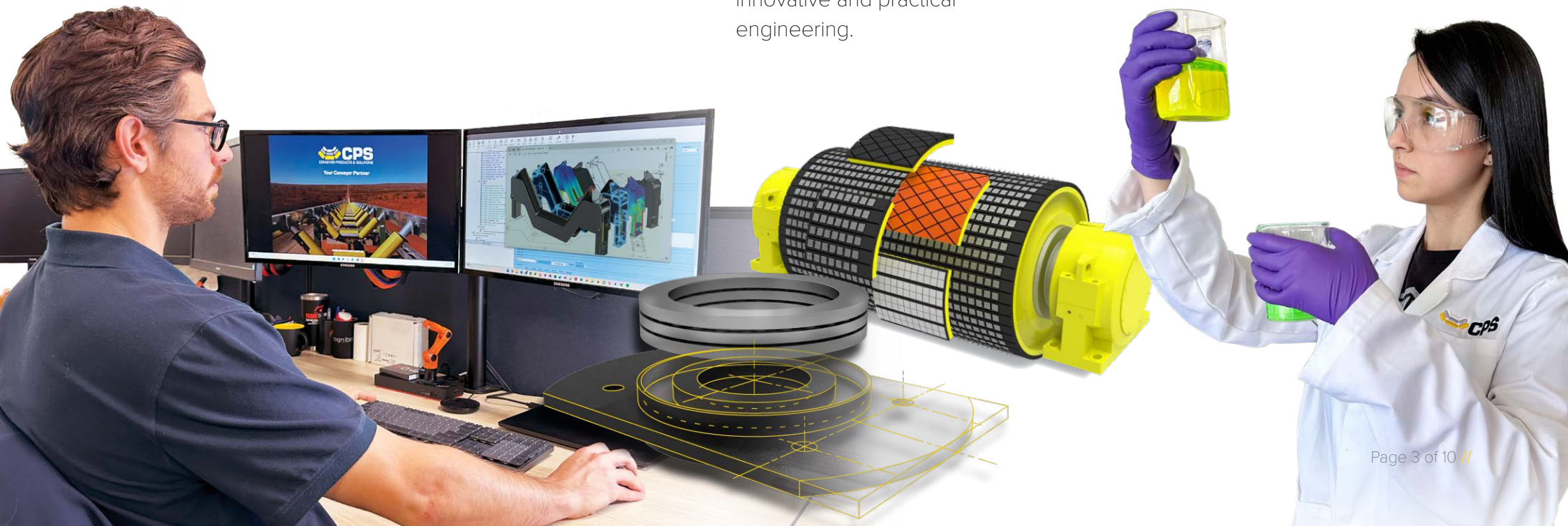

CPS Rollers

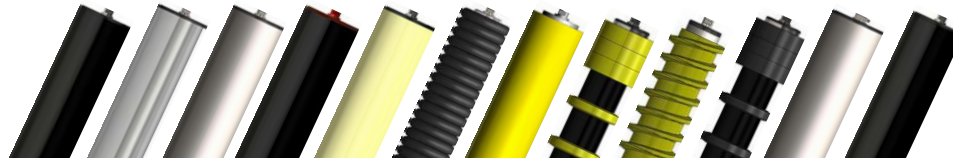

CPS manufacture a complete range of light, medium, and heavy duty conveyor rollers using Composite Bearing Housing technology which are suitable for all applications. The roller construction and manufacturing methods contain several unique features that result in significant improvements over traditional rollers.



Composite Bearing Housing Technology (CBH)

CPS manufactures conveyor rollers using composite bearing housing technology (CBH™). This technology is now used to produce all our steel, aluminium, Yeloroll HD composite and Yeloroll conveyor rollers. Through innovation in design since 2003, we provide a complete range of rollers for light, medium and heavy-duty applications. Our unique design and manufacturing process results in a roller series manufactured to ensure optimum quality, reliability and durability. The roller construction and manufacture incorporate several unique features resulting in significant improvements over traditional rollers.

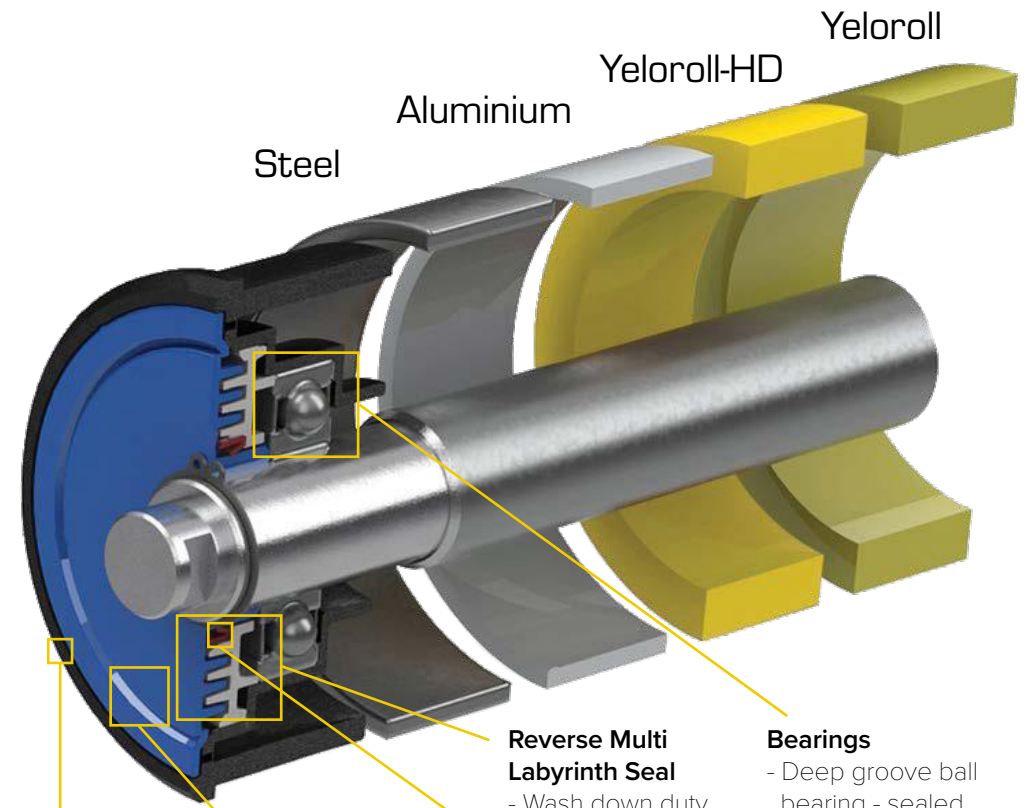

Precision Injected Moulded Housing
 - Anti static pin
 - Press fit / no weld
 - No 'pizza cutter' slicing belts

Fixed Face Flinger
 - Non rotational
 - Covers 80% roll end
 - No rock jams
 - No roller seizures

Contact Seal
 - Water tight
 - No dust
 - No rust

Reverse Multi Labyrinth Seal
 - Wash down duty

Bearings
 - Deep groove ball bearing - sealed for life
 - Extra heavy duty spherical bearings



Yeloroll (114 - 152Ø)

These all-round polymer rollers are 45% lighter than equivalent steel idlers and are highly corrosion-resistant, non-magnetic, and impact-resistant.



Yeloroll HD (127 - 219Ø)

This "Heavy Duty" fibre-reinforced high-density polyethylene shell has increased strength, stiffness, creep resistance, dimensional stability, and has three times the abrasion resistance of standard polymer shell rollers.

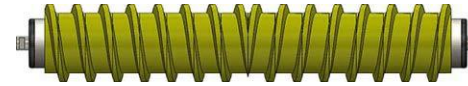

Polyurethane Cleaning Roller (140 & 165Ø)

Manufactured using high wear-resistant polyurethane spiral rings which prevent and assist in cleaning off sticky carry back from the belt.



Rubber Impact Roller (133, 159, & 203Ø)

Manufactured using steel shell and rubber discs, Impact Rollers are used in conveyor loading and transfer point applications to protect the belt where lump material is dropped from height in the transfers.



Polyurethane Full Sleeve Impact Roller (133, 159, 203)

An excellent longer lasting alternative to bullnose or impact disc rollers, these are manufactured using a heavy-duty steel shell and highly wear-resistant polyurethane.



Rubber Disc Roller (133 & 159Ø)

Manufactured using steel shell and rubber discs, they offer a maintenance-free solution in areas where return rollers are failing regularly due to carry back and shell wear.



Polyurethane Disc Roller (133, 159, 181, & 203Ø)

CPS PU Disc Roller is an even longer lasting solution than rubber disc rollers, in areas where return rollers are failing regularly due to carry back and shell wear.



Weigh Roller (89 - 178Ø)

These specialised rollers are machined accurately to 0.05 TIR (Total Indicator Run-out), a 3.2 µm surface finish, and a maximum imbalance of 0.014 Nm/Roll and balance quality G16 as per ISO 1940-1.



Steel Roller (89 - 219Ø)

Produced using CBH™, these belt-friendly steel rollers provide superior balance and high impact resistance.

Hollow Shafts ▷

Further reductions in the weight of rollers are achievable through the employment of hollow shafts. When designed and constructed correctly, this reduction in weight is achieved without compromising shaft strength requirements.

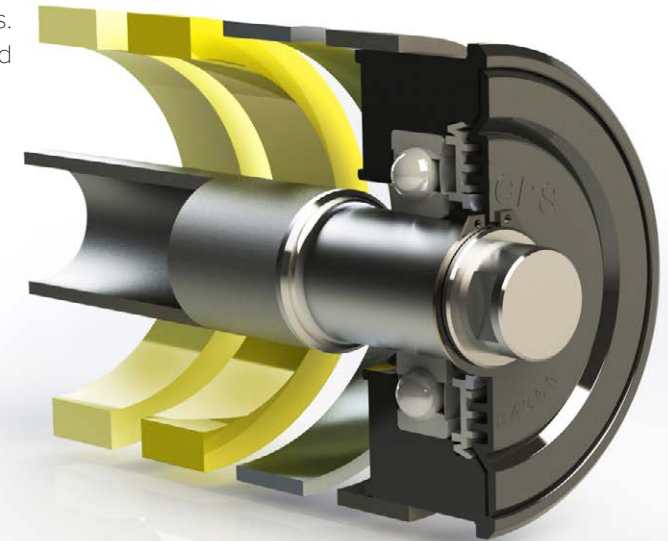

Steel Low Noise Roller (89 - 178Ø)

These have the same extremely tight balance, surface finish, and TIR requirements of weigh rollers. CPS's steel low noise rollers are the quietest rollers tested at TUNRA in almost ten years - June 2016.



Aluminium Low-Noise Roller (89 - 178Ø)

Manufactured using a high-quality alloy tube, these enable the TIR (Total Indicated Run-out) & MIS (Maximum Indicated Slope) of our lightweight, low noise aluminium roller to be naturally low.



Anti Rollback Roller (102,114,127,152,178Ø)

The CPS anti-rollback conveyor roller is a one-directional roller with a patented internal safety device to prevent an inclined conveyor from running backwards in the event of a belt snap or power outage.



Steel Hybrid FRAS Roller (127 - 178Ø)

Specifically manufactured for underground coal mining applications and compliant to the requirements of MDG3608. The Steel Hybrid FRAS roller range combines a steel shell and the CPS FRAS Composite Bearing Housing technology.

Idlers/Frames

CPS designs and manufactures premium quality conveyor idler frames in standard belt width sizes or completely customised to suit individual client requests. Frames are designed using the latest 3D Computer Aided Design software, then processed through our ANSYS Finite Element Analysis system to ensure the frames are fit for duty. CPS utilise multiple manufacturing methods, including robotic welding, to produce idler frames and other associated structures to tolerance and quality levels previously unseen in the conveyor industry.



Decades of experience delivering overland conveyor (OLC) projects make CPS uniquely positioned with proven experience and capability to meet the volume and exacting tolerance demands of large-scale OLC projects as well as smaller after market supply arrangements.

Key strengths include:

- **Engineering Expertise:** Deep understanding of conveyor and idler loadings, supported by our ability to apply standards like BS7608 and AS4100 to handle complex fatigue and overload.
- **Precision In-House Fabrication:** Expertise in meeting strict tolerances while maintaining high output through collaboration with our fabrication teams.
- **Advanced Robotic Processes:** Investment in cutting-edge robotic welding technology has accelerated our prototype-to-production process, ensuring faster and more precise production.



Dual Jacking Impact

Dual Jacking Impact idlers are used where current frames are not sufficiently robust, with rigidity issues, fatigue fracturing, and roller slot elongation due to plastic deformation from repeated impacts and rattling against the hard roller shaft.

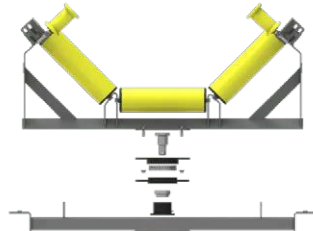

Training/Tracking Frames

CPS Training Frames are designed and equipped with CPS dual bearing pivot for smooth, accurate and reliable belt tracking functions that are built to last. These frames can be manufactured in all typical frame configurations as well as specifically designed for all applications.

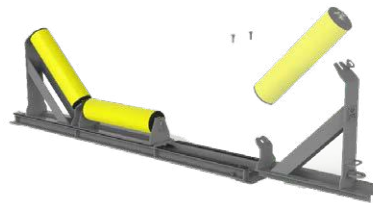

Retractable Idler Frames

Designed and engineered according to industry standards, the CPS Retractable Idler Frames are a great solution for impact zones that require frequent roller change-outs. It enables easy access to rollers without the need to raise the belt. Roller change-outs can be made easier with the CPS retractable idler frames, increasing maintenance efficiencies.



Transition

Transition idlers are adjustable idlers, used in the belt transition zone, which assist the conveyor belt to change from a flat profile across pulleys to a troughed angle. Transition idlers can be custom made for any belt width, with either slotted or drilled hole adjustments.



Flat Carry

Used in take up areas, the Flat Carry idler supports the return side of the belt where no troughing angle is necessary. Like all CPS idlers, Flat Carry idlers can be custom made to suit your project requirements.



Jacking Carry

Jacking carry impact idlers are a heavy-duty, high performance solution used in conveyor impact zones under the skirt. CPS pioneered single jacking impact idlers for extreme-duty applications. Jacking idlers can be designed in multiple configurations including single and dual arrangements for any belt.



Retractable Carry

Maintenance-friendly Retractable Carry idlers provide HSE safety benefits by allowing roller change outs from walkways. Retractable Carry idlers can be custom made for any belt width, in multiple roll configurations to suit your project requirements.



5 Roll Carry

As they distribute conveyor loads across more bearings, 5 Roll Carry idlers allow for lighter weight rollers, providing significant HSE safety benefits. 5 Roll Carry idlers can be custom made to any width to suit your project requirements.



Carry Training

Carry Training idlers provide a method for actively realigning the belt during operation, resulting in better overall performance and reduced downtime. CPS' custom designed pivot assembly is fully serviceable and replaceable. Carry Training idlers can be custom made for any belt width to your project requirements.



Flat Return Training

Flat Return Training idlers provide a similar dynamic alignment method for the carry side of the belt as the Carry Training idler provides to the return side. These positive action training frames can be custom made for any belt width to your project requirements. CPS' custom designed pivot assembly is fully serviceable and replaceable.



Flat Return

Providing support for the return length of the belt, Flat Return idlers support the belt in flat areas near pulleys. CPS can custom manufacture these idlers using quality materials right here in Australia to suit your project requirements. Flat return idlers can be supplied with a low-maintenance cleaning solution complete with the CPS PU Disc Rollers.



Flat Disc Return

Flat Disc Return idlers are a low-maintenance cleaning solution complete with the CPS PU Disc Roller. Flat Disc Return idlers can be custom made for any belt width to your project requirements.



Vee Return

The Vee Return idler provides best value to applications where a vee orientation is required on the return side to assist with tracking and ensure peak performance. Vee Return idlers can be custom made for any belt width to your project requirements. Vee return idlers can be supplied with a low-maintenance cleaning solution complete with the CPS PU Disc Rollers.



Suspended Return

Chain return style Suspended Return idlers are an easy removal option primarily used in underground coal. When set up correctly, similar to Vee Return Idlers, Suspended Return idlers can assist with centralising the belt. Suspended Return idlers can be custom made for any belt width to your project requirements.





Precision Engineered Conveyor Pulleys

CPS uses the highest quality engineering processes and standards to ensure every pulley is optimised. This includes utilising industry-leading FEA techniques to design and understand the whole pulley assembly under design conditions, as opposed to looking at each component separately. Our engineering approach also drives long-time cost reductions, providing cost-effective refurbishment and commonality capacity within each design.

Customised Specifications for Varied Applications

CPS offers a significant and custom range of pulley specifications to suit any application. Our engineering specifications allow our clients to select and choose from an endless variety of options. As with everything we design and manufacture for the bulk materials handling industry, CPS believes that ongoing close collaboration with our clients ultimately drives the best specifications and hence, we pride ourselves on our bespoke engineering approach to ensure the right specification for the right application.

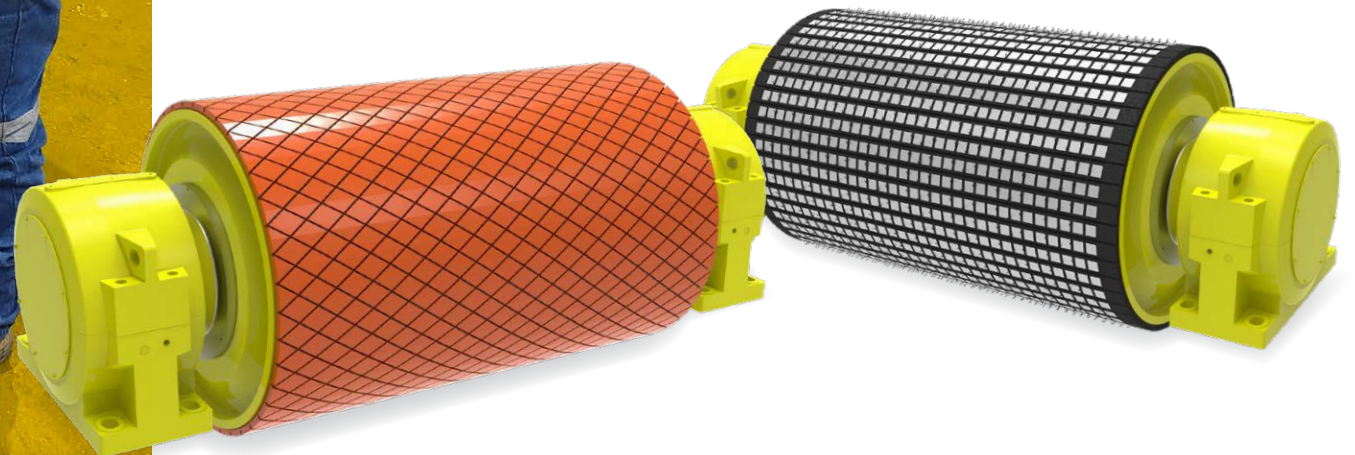

End Disc Options

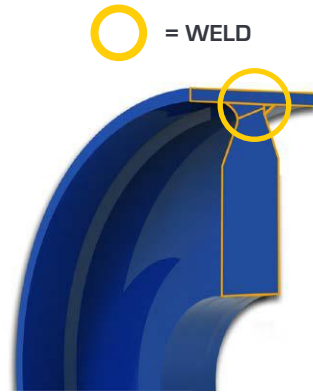

T-Section

- Solid end discs
- Machined to eliminate welds on end disc
- Joins with butt welds and rim to form 'T' cross section
- Meets customer specific load and tensions
- Fabric and steel cable belts over 2500 PIW
- Designed for use with heaviest series of keyless locking devices

Turbine End Disc

- Solid profiled end disc
- Machining both sides reduces stress and eliminates hub to end disc welds
- Designed for keyless locking devices
- Stress free assembly without damaging effect of keyways

Lagging Options

CPS pulleys can be customised with a variety of lagging systems to protect the pulley face from wear and provide better traction to the belt including:

- Direct Bond Ceramic
- Hot Cast Polyurethane
- Cold Bond
- Hot Vulcanised

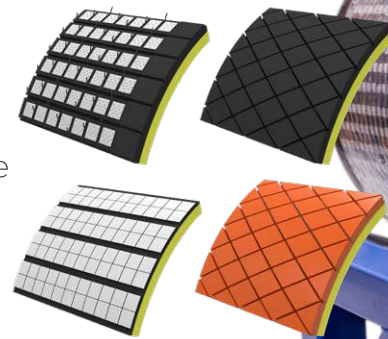

Pulley Refurbish

At CPS we refurbish a myriad of conveyor pulley types to provide a significant cost saving and greatly reduced lead time compared to the build of a new pulley. In addition, our six-step preliminary inspection (provided as standard), can eliminate thousands of dollars potentially wasted on attempting to strip & assess pulleys that are no longer workable.





Head Office
Perth, Western Australia

69 Dowd Street, Welshpool, WA 6106

Phone: +61 8 9458 4366 **Fax:** +61 8 9458 4388

Sales: sales@cpsconveyors.com.au

General Inquiries: info@cpsconveyors.com.au

Pulley and Fabrication Facility
Perth, Western Australia

34 Clune Street, Bayswater, WA 6053

LATAM Sales Office
Santiago, Chile

Phone: +56 9 6229 2601

General Inquiries:

info@cpsconveyors.cl