



**HE2020**  
HOSPITALITY EQUIPMENT 2020 PTY LTD



# ICE MACHINES & ICE BINS BROCHURE



**HOSPITALITY EQUIPMENT 2020 Pty Ltd.**  
Unit 3/49-63 Victoria Street, Smithfield,  
NSW 2164 Australia  
[www.greenline.net.au](http://www.greenline.net.au) | [www.he2020.com.au](http://www.he2020.com.au)  
02 9637 3737 | [salesnsw@he2020.com.au](mailto:salesnsw@he2020.com.au)

# ICE MAKER SELF CONTAINED



## INVEST IN YOUR OWN ICE MAKER

Having a restaurant, bar, hotel or casino means that there will be a constant demand for cold beverages from your customers.

And while you have the option to source your ice from a third-party supplier, investing in your own commercial ice maker is still one of the smartest moves that you can make to save time, money and resources while making sure that you keep your customers satisfied.

### QC25A (25KG)

W500 x D485 x H840mm

#### Features:

Stainless steel construction Light doors  
Durable spray system  
Ambient temperature: 21 °C  
Water Temperature: 10 °C

#### Specifications

Production capacity: 25kg/24hrs  
Storage: 16kg  
Cube size: 22 x 22 x 22mm  
Ice tray: 5\*8  
Compressor: Donper  
Voltage: 220V/50Hz  
Power: 260W

### QC40A (40KG)

W500 x D485 x H840mm

#### Features:

Stainless steel construction Light doors  
Durable spray system  
Ambient temperature: 21 °C  
Water Temperature: 10 °C

#### Specifications

Production capacity: 40kg/24hrs  
Storage: 16kg  
Cube size: 22 x 22 x 22mm  
Ice tray: 5\*10  
Compressor: Donper  
Voltage: 220V/50Hz  
Power: 350W

### QC50A (50KG)

W500 x D620 x H840mm

#### Features:

Stainless steel construction Light doors  
Durable spray system  
Ambient temperature: 21 °C  
Water Temperature: 10 °C

#### Specifications

Production capacity: 50kg/24hrs  
Storage: 21kg  
Cube size: 22 x 22 x 22mm  
Ice tray: 5\*12  
Compressor: Donper  
Voltage: 220V/50Hz  
Power: 400W

### QC130A (130KG)

W665 x D725 x H910mm

#### Features:

Stainless steel construction Light doors  
Durable spray system Ambient temperature: 21 °C  
Water Temperature: 10 °C

#### Specifications

Production capacity: 130kg/24hrs  
Storage: 35kg  
Cube size: 22 x 22 x 22mm  
Ice tray: 8\*18  
Compressor: Donper  
Voltage: 220V/50Hz  
Power: 900W



CALL US - 02-9637 3737

EMAIL US - salesnsw@he2020.com.au

WEBSITE: greenline.net.au

2

# ICE MAKER SELF CONTAINED



QC25A

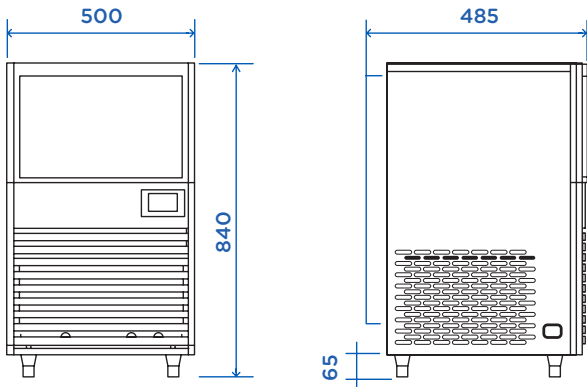

QC40A

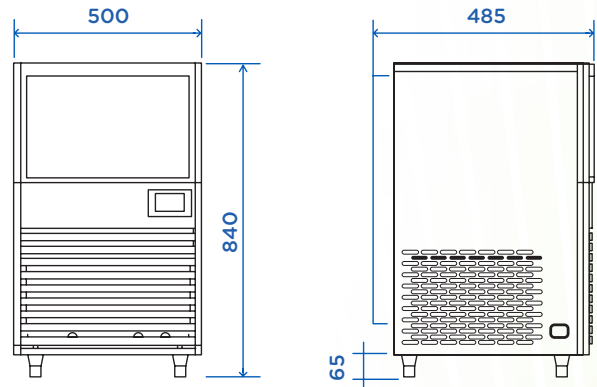

QC50A

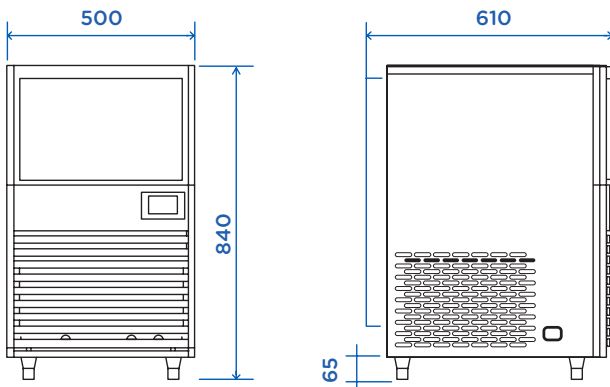

QC130A

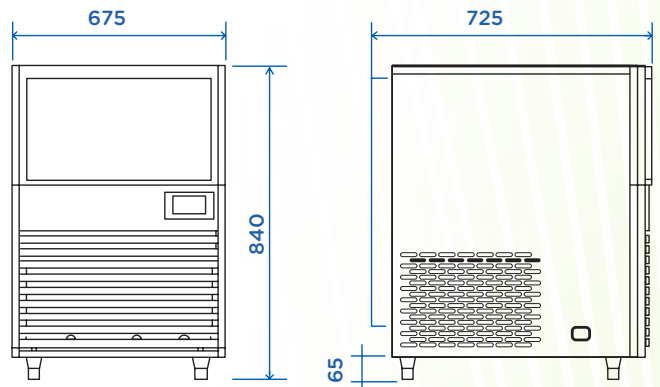

CALL US - 02-9637 3737

EMAIL US - [salesnsw@he2020.com.au](mailto:salesnsw@he2020.com.au)

WEBSITE: [greenline.net.au](http://greenline.net.au)

3

**HE2020**  
HOSPITALITY EQUIPMENT 2020 PTY LTD

HOSPITALITY EQUIPMENT 2020 Pty Ltd.  
[www.he2020.com.au](http://www.he2020.com.au)  
Unit 3/49-63 Victoria Street,  
Smithfield, NSW 2164 Australia

LAVA  
RANGE

lamber®

Jemi®  
Simply The Best

# MODULAR ICE MAKER



## ICE MAKERS THAT CAN CREATE UP TO 450 KG A DAY



### QC250A (250KG) W785 x D930 x H600mm (w/o bin)

#### Features:

Stainless steel construction  
Light doors  
Durable spray system Ambient temperature: 21 °C Water Temperature: 10 °C

#### Specifications

Production capacity: 250kg/24hrs  
Storage: 200kg  
Cube size: 22 x 22 x 22mm  
Ice tray: 15\*18  
Refrigerant: R404a  
Compressor: Embraco  
Voltage: 220V/50Hz  
Power: 1350W

### QC300A (330KG) W785 x D930 x H685mm (w/o bin)

#### Features:

Stainless steel construction  
Light doors  
Durable spray system Ambient temperature: 21 °C Water Temperature: 10 °C

#### Specifications

Production capacity: 300kg/24hrs  
Storage: 200kg  
Cube size: 22 x 22 x 22mm  
Ice tray: 17\*18  
Refrigerant: R404a  
Compressor: Embraco  
Voltage: 220V/50Hz  
Power: 1350W

### QC450A (450KG) W785 x D930 x H795mm (w/o bin)

#### Features:

Stainless steel construction  
Light doors  
Durable spray system Ambient temperature: 21 °C Water Temperature: 10 °C

#### Specifications

Production capacity: 450kg/24hrs  
Storage: 455kg  
Cube size: 22 x 22 x 22mm Ice tray: 22\*20  
Refrigerant: R404a  
Compressor: Tecumseh  
Voltage: 220V/50Hz  
Power: 2350W

You can rely on our team to help you find the best commercial ice maker machine to suit your needs. We have ice makers that can create up to 450 kilos of ice in 24 hours, but we also have smaller varieties that can produce 40 kgs of ice in a day. You can opt for a small commercial ice maker machine or a big one, depending on the capacity that you need for your operations.



### QCB140 (140KG) W585 x D910 x H920+160mm

### QCB200 (200KG) W785 x D930 x H1000+160mm

Storage Capacity 200kg Suitable for Ice makers: QC250A , QC300A

### QCB140 140KG W1230 x D1030 x H1000+160mm

Storage Capacity 455kg Suitable for Ice makers: QC450A



CALL US - 02-9637 3737

EMAIL US - salesnsw@he2020.com.au

WEBSITE: greenline.net.au

4

**HE2020**  
HOSPITALITY EQUIPMENT 2020 PTY LTD

HOSPITALITY EQUIPMENT 2020 Pty Ltd.  
www.he2020.com.au  
Unit 3/49-63 Victoria Street,  
Smithfield, NSW 2164 Australia



# MODULAR ICE MAKER



**QC250A**

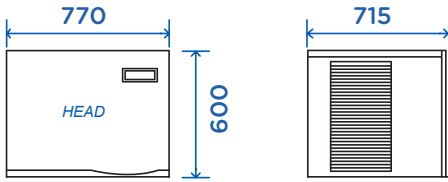

**QC300A**

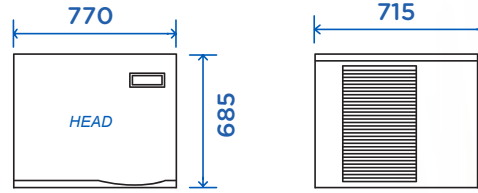

**QC450A**

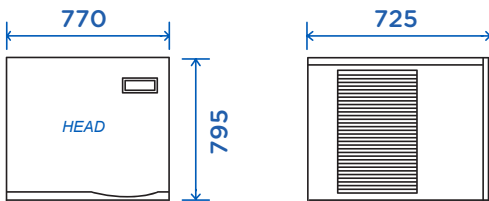

**QCB140**

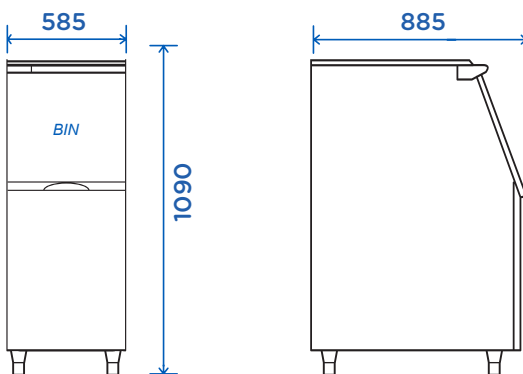

**QCB200**

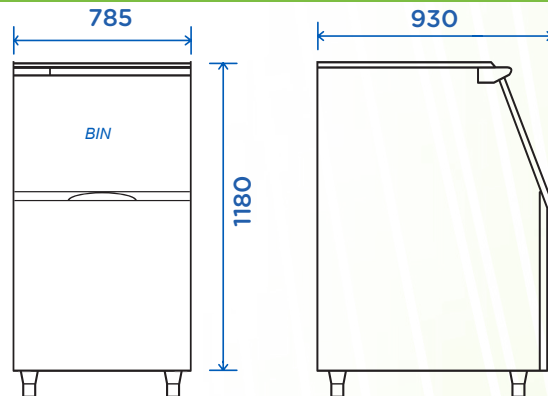

**QCB455**

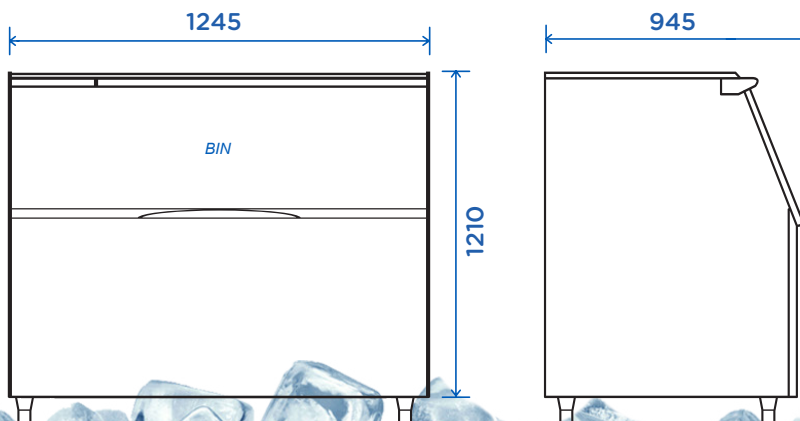

CALL US - 02-9637 3737

EMAIL US - salesnsw@he2020.com.au

WEBSITE: greenline.net.au

5

**HE2020**  
HOSPITALITY EQUIPMENT 2020 PTY LTD

**HOSPITALITY EQUIPMENT 2020 Pty Ltd.**  
www.he2020.com.au  
Unit 3/49-63 Victoria Street,  
Smithfield, NSW 2164 Australia





# GREEN

# Line



**CONTACT US FOR A SOLUTION THAT WORKS FOR YOU!**

Unit 3/49-63 Victoria Street, Smithfield, NSW 2164 Australia

02 9637 3737 | [salesnsw@he2020.com.au](mailto:salesnsw@he2020.com.au)

[www.he2020.com.au](http://www.he2020.com.au) | [www.greenline.com.au](http://www.greenline.com.au)

