

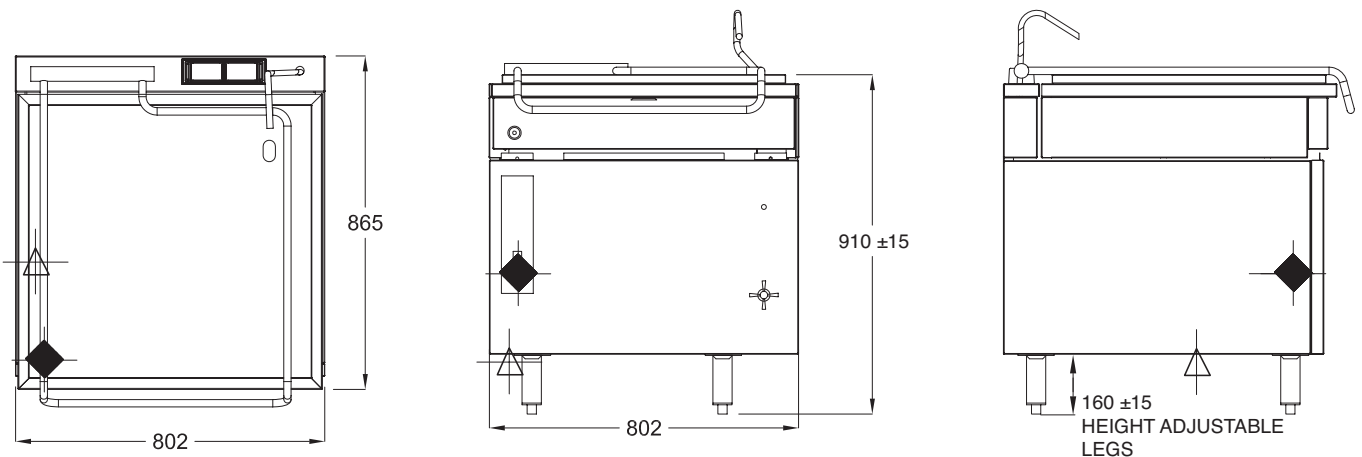

# 800 SERIES PRATT PAN

## TPE80 - Electric

- Capacity of 60 litre Stainless Steel Pan
- 10mm thick Duplex seamless Stainless Steel base provides improved heat retention, even heat and ease of cleaning
- Electric tilt as standard
- Thermostatically controlled
- Ergonomically designed counter balanced lid with heavy duty hinge
- Heavy duty fully welded Stainless Steel frame ensures rigidity and durability



### TPE80

#### SPECIFICATIONS

<b>Dimensions (WxDxH)</b>	802 x 865 x 920 mm
<b>Working height</b>	825 mm
<b>Pan Size (WxDxH)</b>	695 x 670 x 195 mm
<b>Capacity</b>	60 L

◆ Electrical Wire Inlet (12kW/3 Phase)

⚓ 1/2" Pipe Water Inlet

<b>Electric Connection</b>	3 phase, 415V+N+V
<b>Rating</b>	12 kW
<b>Weight</b>	159 kg
<b>Packed</b>	0.6 m <sup>3</sup>

Australia's premier food service  
equipment manufacturer

[goldstein.com.au](http://goldstein.com.au)

211-217 Woodpark Road, Smithfield NSW 2164  
1800 013 123 | +61 2 9604 7333

 **MIDDLEBY AUSTRALIA**

