

# Grande Flammes MILLENIUM

## 975.5 MLG/MSG/MiG

### DESIGN

The MILLENIUM range of attractive ergonomically-designed rotisseries, boasts a number of innovative features for increased functionality and are an ideal show-piece used throughout the world in hotels, restaurants and deli stores.

The naked flame from Rotisol's patented burners lick the cast iron hearth creating a spectacular visual, whilst being safe and simple to operate and easy to clean. Spits are driven by individual motors rotating at 2 ½ times per minute allowing meat or poultry to constantly baste itself, sealing in natural juices and cooking to perfection.

### FEATURES

- Energy Efficient
- Independent motors
- 2 tempered glass doors
- Safety with installed thermocouple
- Equipped with bottom drip tray with drainage tap
- Powerful halogen lamp.

### FINISHES

Standard model in black enamel. A choice of other colours are available. Choses a colour scheme for Millenium.



With chrome or brass trims.

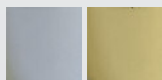

All Millenium models are supplied as standard with;

- a full set of chicken spits (either model CUI prongless spits, or BP spits with prongs), and
- a set of spit adjustment tools (model DEC)

### ACCESSORIES









A variety of accessories are available for the unit. Video of available [accessories](#) and video of [vertical spit system](#).



**975.5MLG**

Full black enamel finish w/-  
luxe brass trims

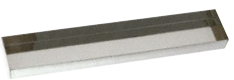

<b>CUI975</b> Anti-cutting prongless spit. 	<b>BP975</b> Chicken spit. 	<b>BRC975</b> Basket spit. 
<b>BS975</b> Sabre spit for ham / turkey. 	<b>BRRO975</b> Roast-clamp spit. 	<b>BA975</b> Lamb/suckling- pig spit. On demand. 
<b>GCP975</b> Spare rib rack. 	<b>GSV975</b> Raised rack for meat storage. 	<b>PID975</b> Stainless steel tray to unspit. 

**Front view**  
Rotisserie with roof (optional)  
and base on casters (optional)

**Side view**  
Rotisserie with roof (optional)  
and base on casters (optional)

**Top view**  
Rotisserie with roof (optional)  
and base on casters (optional)

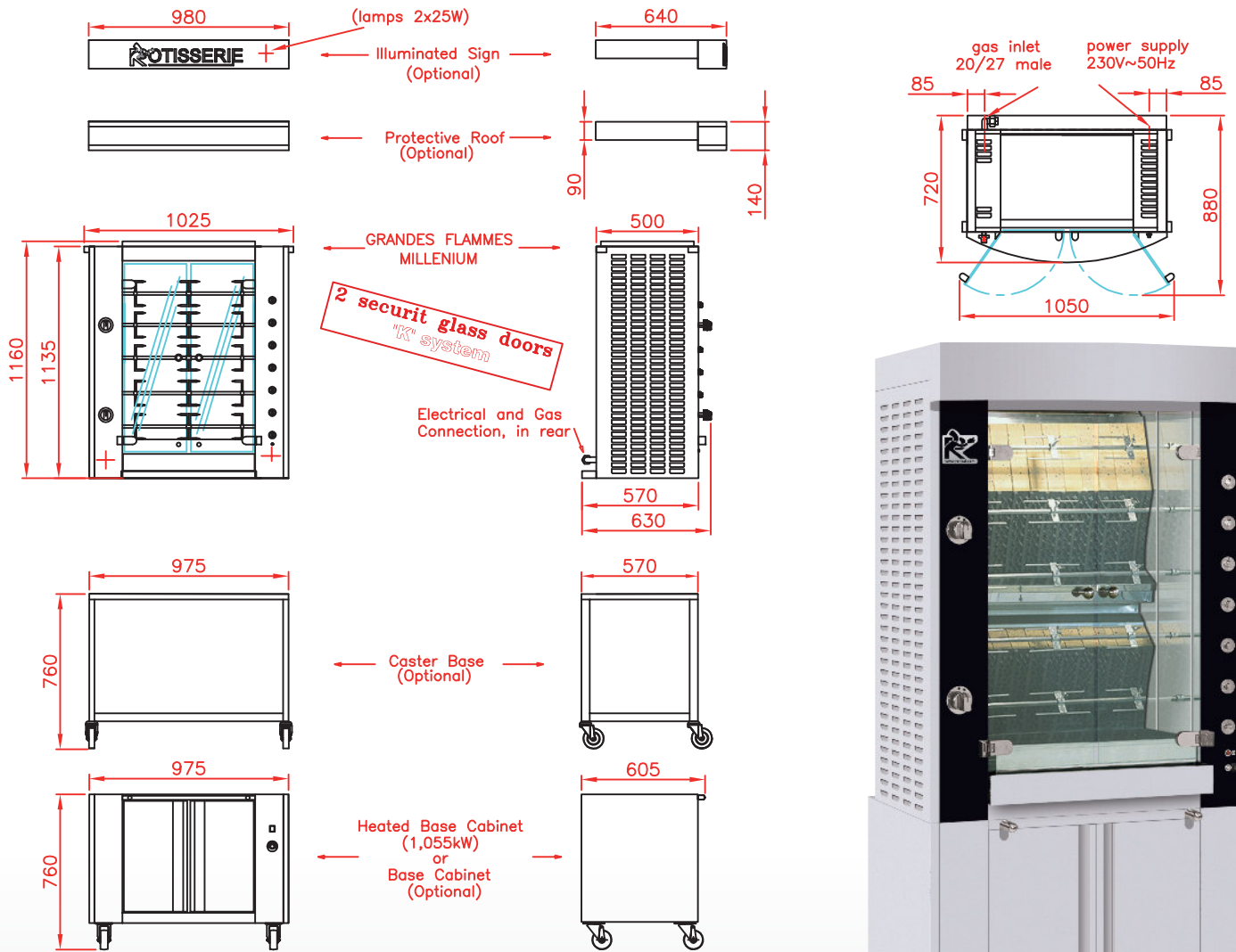

Stainless steel finish w/  
black enamel front panels

### SPECIFICATIONS

<b>Gas Power</b>	NG 27kW / LPG 21kW
<b>Gas consumption</b>	Natural Gas 97.2 Mj/hr LPG 75.6 Mj/hr
<b>Gas connection</b>	20/27 male
<b>Electricity</b>	230 V 50 Hz + earth 0.4 kW
<b>Capacity</b>	10/15 chickens (depending on size)
<b>Warranty</b>	1 year on parts (excluding glass doors)
<b>Extraction</b>	Compulsory
<b>Minimum clearance</b>	5 cm on the left and right, 5 cm at the rear
<b>Weight</b>	140 kg without packing

### Model Descriptions

**MLG** - Full black enamel finish with luxe brass or chrome trims, (other colours available).  
**MSG** - All stainless steel with black enamel front control panels, (other colours available).  
**MiG** - All stainless steel with polished S/S front.



Revised : February 2018

### Authorised Dealer

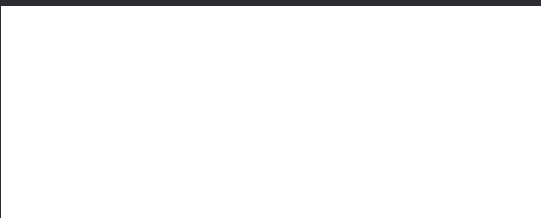

### AUSTRALIAN IMPORTER & DISTRIBUTOR



ABN 91 600 066 340

PO Box 83,  
Oxenford, QLD 4210

Ph: 0490 526 758

EMAIL: [info@creative-commercial.com.au](mailto:info@creative-commercial.com.au)

[www.creative-commercial.com.au](http://www.creative-commercial.com.au)