



# QUON 8-Litre

## CD 25 360

6x2 Rigid



### SPECIFICATIONS

<b>Power:</b>	263 kW (357 PS) @ 2200 rpm
<b>Torque:</b>	1428 Nm (1055 lb.ft) @ 1200 rpm
<b>Transmission:</b>	ESCOT-VI automated manual transmission (AMT)
<b>Suspension:</b>	Air bag suspension
<b>Wheelbase:</b>	5700 mm (V-wheelbase)
<b>GVM:</b>	25,000 kg
<b>GCM:</b>	38,000 kg

### QUON UNIQUE FEATURES



#### SMART FUEL EFFICIENCY AND RESPECT FOR THE ENVIRONMENT

GH8 engine: fuel efficient, powerful and clean.



#### SMART UPTIME

Quon has been designed to further optimise uptime, with superior reliability and increased maintenance intervals.



#### SMART SAFETY

Active safety with mechanical and electronic features throughout.



#### SMART PRODUCTIVITY

Light weight chassis helping to maximise payload.



#### SMART DRIVABILITY

The cabin has been designed with the user's comfort in mind, with outstanding ergonomics and visibility allowing the driver to concentrate on driving.

## GENERAL SPECIFICATIONS

### SAFETY

<b>Passive Safety:</b>	Highly rigid cabin Side door beams Front underrun protection system (FUPS) ECER29 cab strength rating SRS driver steering wheel airbag Driver side seat belt with pre-tensioner Steering wheel & column with impact absorption function
<b>Active Safety:</b>	Traffic Eye Brake System Traffic Eye Cruise Control LDWS (Lane Departure Warning System) Electronic Stability Control (UDSC) Automatic Hill Start Assist (HSA)
<b>Basic Safety:</b>	LED Headlamps (low beam) Disc brakes Anti Locking Brake System Emergency Braking System UD Extra Engine Braking (UD EEB) Safe Brake Blending Immobiliser Two-step entry & exit

### ENGINE

<b>Model:</b>	GH8F
<b>Description:</b>	6 cylinder, 4 stroke diesel engine
<b>Displacement:</b>	7,698 cc
<b>Bore x stroke:</b>	110 mm x 135 mm
<b>Compression ratio:</b>	17.5:1
<b>Max. Power (ECE Net):</b>	263 kW (357PS) @ 2,200 rpm
<b>Max. Torque (ECE Net):</b>	1,428 Nm (1,050 lb.ft) @ 1,200 rpm
<b>Max. governed engine speed:</b>	2,400 rpm

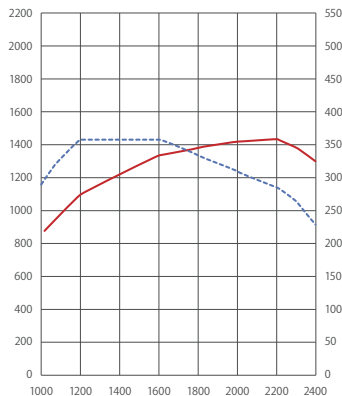

### FUEL AND INTAKE SYSTEM

<b>Fuel capacity:</b>	400 litres
<b>Injection type:</b>	High pressure common rail direct fuel injection system
<b>Filtration:</b>	Chassis mounted primary filter and engine mounted secondary filter

### EMISSION CONTROL

<b>Emission standard:</b>	pPNLT (equivalent to Euro 6 emission requirements)
<b>Adblue capacity:</b>	50 litres
<b>Exhaust system:</b>	RHS chassis mounted box muffler

### ELECTRICAL

<b>Power:</b>	24 volt, negative ground system
<b>Battery capacity:</b>	2 x 12 volt 135 Ah batteries
<b>Alternator:</b>	110 amp

### TRANSMISSION - ESCOT

<b>Make:</b>	UD Trucks		
<b>Model:</b>	ESCOT-VI (AT2612F)		
<b>Description:</b>	Automated manual transmission (AMT)		
<b>Shift type:</b>	12 forward & 2 reverse gears		
<b>Gear ratios:</b>	Electronic shifter with fully automatic or manual control		
<b>1<sup>st</sup></b>	14.94	<b>7<sup>th</sup></b>	3.44
<b>2<sup>nd</sup></b>	11.73	<b>8<sup>th</sup></b>	2.70
<b>3<sup>rd</sup></b>	9.04	<b>9<sup>th</sup></b>	2.08
<b>4<sup>th</sup></b>	7.09	<b>10<sup>th</sup></b>	1.63
<b>5<sup>th</sup></b>	5.54	<b>11<sup>th</sup></b>	1.27
<b>6<sup>th</sup></b>	4.35	<b>12<sup>th</sup></b>	1.00
<b>Rev 1</b>	17.48	<b>Rev 2</b>	13.73
<b>PTO capacity:</b>	1000 Nm @ 70% or 90% (PTR-D)		

### FRONT AXLE AND SUSPENSION SYSTEM

<b>Ground capacity:</b>	8,200 kg
<b>Axle type:</b>	Reverse Elliot I-Beam
<b>Suspension:</b>	Parabolic leaf spring with shock absorbers
<b>Spring dimensions:</b>	90mm x 1460mm
<b>Spring constant:</b>	347.7 N/mm

### REAR AXLE AND SUSPENSION SYSTEM

<b>Ground capacity:</b>	20,000 kg
<b>Axle type / model:</b>	Single reduction, hypoid gear, with cross locks.
<b>Final reduction ratio:</b>	3.36, 3.70

### AIR SUSPENSION

<b>Description:</b>	8 air bag
<b>Shock absorbers:</b>	4 telescopic double acting
<b>Road friendly certification number:</b>	RF2099 (air only)
<b>Control system:</b>	Electronic Controlled Air Suspension with remote control mounted in cab (ECAS4)

### BRAKES

<b>Type:</b>	Electronic braking system (EBS) with disc brakes on all axles
<b>Front/Rear:</b>	430 mm rotors / 430 mm rotors
<b>Park brakes:</b>	Hand-operated pneumatic spring park brake on drive axles
<b>Auxiliary brake:</b>	Exhaust plus engine compression type (EEB)
<b>Trailer connections:</b>	Air and electrical connections to rear of chassis

### STEERING

<b>Type:</b>	Recirculating ball and screw with hydraulic assist
<b>Steering gear ratio:</b>	24.1 - 26.8 : 1
<b>Column:</b>	Adjustable, tilt and telescopic control
<b>Steering wheel:</b>	460 mm diameter with ignition key steering lock

## WHEELS & TYRES

<b>Wheels:</b>	8.25in x 22.5in steel rim with 165mm offset and ISO 10 stud pattern (335mm PCD)
<b>Front tyres:</b>	295/80 R22.5 Bridgestone R150Z
<b>Rear tyres:</b>	11R 22.5 Bridgestone MZ11AZ
<b>Spare tyre:</b>	295/80 R22.5 Bridgestone R150Z

## FRAME

<b>Width:</b>	850 mm
<b>Side rail dimensions:</b>	300 mm x 90 mm x 7 mm
<b>Material:</b>	Rolled high tensile carbon steel
<b>Tensile strength:</b>	600MPa / 600N/mm <sup>2</sup>

## DRIVER INFORMATION & CUSTOMISABLE COLOUR DISPLAY SCREEN

<b>In Dash Warning Systems:</b>	Visual warning lamps with audible warning tones plus written warnings displayed in full colour on the information screen
<b>In Dash Driver Assistance:</b>	Customisable live information includes: On board fuel coaching with economy tips, fuel & AdBlue usage, instant fuel consumption, digital speedo, trip computer including time, distance & distance to empty.  Hour meter, coolant temp, engine oil temp, transmission oil temp, UDPC level and volt meter.

## INTERNAL CABIN

<b>Lighting:</b>	Dual ON/OFF/DOOR interior lights Interior neon cabin lamp
<b>Seating capacity:</b>	Three
<b>Driver's seat:</b>	ISRI 6860/875 air suspended seat with integrated seat belt & adjustable arm rest. Adjustable height control & rebound damper. With split seat back adjustments for recline & head rest position. Seat base tilt, seat cushion slide, seat air dump switch. Adjustable air bladders (4) for side bolsters, upper & lower lumbar
<b>Passenger seat/s:</b>	Assistant seat with adjustable head rest Foldable centre seat, if fitted
<b>Sleeping capability:</b>	ADR 42/04 compliant sleeper bunk with mattress
<b>Side windows:</b>	Power operated door glass with auto up & down to driver's window. Isolation switch for passenger side window.
<b>Security:</b>	Remote central locking with immobiliser
<b>Air conditioning:</b>	Fully automatic climate controlled airconditioning with recirculation filter.
<b>Multimedia unit:</b>	8 inch high definition capacitive touchscreen with tilting function, AM-FM radio, digital radio & internet radio (requires phone data), USB & auxiliary ports & PDF reader, standard WDR digital reverse camera with microphone & infra-red function, four additional camera inputs with split screen functionality, Wi-Fi & phone tethering enabled, bluetooth handsfree operation.

<b>Multimedia Unit (continued):</b>	Android connectivity, Apple connectivity with Siri inputs, truck specific satellite navigation with 3 free map upgrades. Options available: cordless Qi rated phone charging pocket, tyre pressure monitoring & reverse sensors
<b>Storage:</b>	Multiple in-cab compartments
<b>Power outlet:</b>	24 volt 240W & 12 volt 120W in dash
<b>DIN accessory fitment:</b>	Two DIN sized compartments
<b>Floor covering:</b>	Vinyl

## EXTERNAL CABIN

<b>Cab Description:</b>	Forward control, pressed steel construction
<b>Mounting type:</b>	Full floating, 4 bag air suspended cab with 4 dual acting shock absorbers and dual automatic height control valves
<b>Cab paint:</b>	Standard – "Polar White"
<b>Inspection points:</b>	Back of the cab and front panel
<b>Bumper type:</b>	3 piece with steel corner panels
<b>Mirrors:</b>	Heated & electrically operated main mirrors with flat glass, wide vision & passenger-side downward facing spot mirrors
<b>Lamps:</b>	LED head lamps (low beam) Bumper mounted fog lamps Roof mounted clearance lights
<b>Wipers:</b>	Triple arm, 2 speed wipers with variable intermittent operation & integrated washers
<b>Reversing system:</b>	Reverse beeper and digital infrared camera with microphone

## UD TELEMATICS (FLEET MANAGEMENT)

<b>Telematics hardware:</b>	In-cab GSM and GPS unit with SIM-card connected to roof antenna
<b>Subscription:</b>	12 months included
<b>Packages:</b>	Fuel and Environment   Positioning
<b>Key Reports:</b>	Total operational time and distance Average speed and fuel consumption Total CO <sub>2</sub> emission Vehicle utilisation Anticipating & braking Engine & gear utilisation Speed adaptation Time idling (standstill)

## FACTORY OPTIONAL EQUIPMENT

<b>Tyres:</b>	275/70 R22.5
<b>Wheels:</b>	Alcoa aluminium wheels
<b>Rear engine PTO:</b>	DIN 5462 or Flange SAE1410, 650 Nm capacity
<b>Safety:</b>	Driver Alert System
<b>UD Telematics:</b>	Positioning+ package
<b>Cab paint:</b>	Custom paint colours
<b>Cab Interior:</b>	Leather steering wheel, Woodgrain dash, Centre console or 2nd passenger seat
<b>Cab Exterior:</b>	Roof scoop, Chrome grille, Roof beacon prep kit, Bumper spoiler, passenger door peep window, cab auxilliary side windows
<b>Additional Wheelbases:</b>	4,700mm, 5,100mm
<b>Chassis:</b>	Front axle stabiliser bar

# MAJOR DIMENSIONS

Variant	Wheelbase code	Mass (kg)					Vehicle Dimensions (mm)															Turning radius (kerb to kerb)	UD order code		
		GVM*	GCM	Front Tare <sup>1,3</sup>	Rear Tare <sup>1,3</sup>	Total Tare <sup>1,3</sup>	WB	TWB	OL	OW	OH	FT <sup>4</sup>	RT <sup>4</sup>	FW	AS	FOH	ROH	RFL	BOC	CA	GC <sup>2</sup>			FHF <sup>2</sup>	FHR <sup>2</sup>
UD – Air	V	25000 kg	38000 kg	4000	3280	7280	5700	6385	11474	2490	2970	2044	1833	850	1370	1392	3610	4295	715	4985	201	1027	1029	9800	CD25360VAA

\*Rated GVM and axle capacities are subject to Federal, State and Territory legal requirements.

<sup>1</sup> Mass is an estimation based only on standard model, includes fluids (no diesel fuel or Adblue®). Excludes spare wheel. Excludes driver and tools. Subject to ± 3% tolerance.

<sup>2</sup> Based on vehicle with standard wheels and tyres

<sup>3</sup> For alloy rims deduct 28kg from Front Tare and deduct 111kg from Rear Tare

<sup>4</sup> For alloy rims add 18mm to both FT and RT measurements

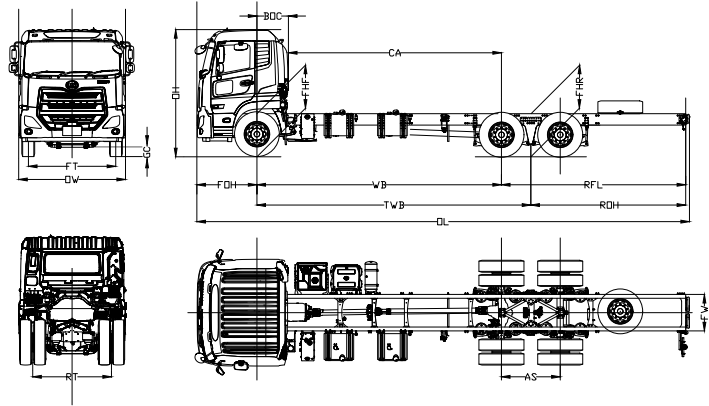

# WARRANTY

<b>Standard warranty<sup>+</sup></b>	36 months / 500,000 kms
<b>Cab corrosion warranty<sup>+</sup></b>	36 months / unlimited kms
<b>Extended warranty<sup>++</sup></b>	60 months / 500,000 kms

<sup>+</sup>For details refer to your UD Trucks New Vehicle Warranty brochure

<sup>++</sup>Purchased by the owner and covers selected factory items only. For details refer to your UD Trucks New Vehicle Warranty brochure