

Electric Pallet Wrapping Turntable - Rotates - Adjustable Speed - 2000kg Capacity - AS/NZS Certified

Electric Turntable- Rotates- 2000kg Capacity reduces the chance of tripping, back injuries or dizziness when walking around a pallet due to its unique rotating feature. Safety and controls are assured with a protected foot pedal that allows the operator to guide the film onto cartons neatly and conveniently.

Meets Australian Standards

Conforms to AS/NZS 3820:2009 and AS/NZS 4024.1204:2019

Features

- All Steel Construction.
- Operated by foot pedal switch.
- Fork pockets, easily moved by forklift.
- Dramatically reduces the effort required to palletise goods.
- Built-in turntable allows simple load rotation and access to all sides.
- Powder coated safety yellow for hi visibility and extra protection from wear and tear.
- Durable and tough, this pallet leveller can be used in a wide range of applications including warehousing.

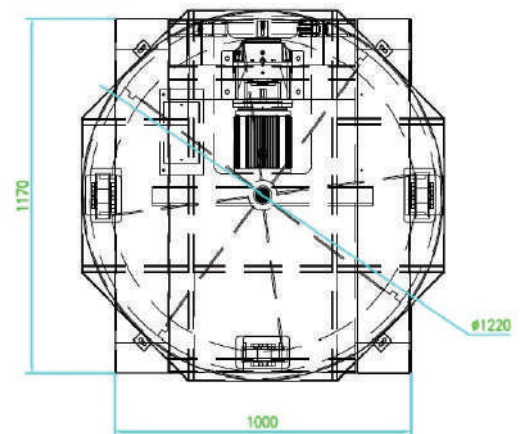
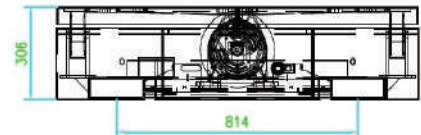
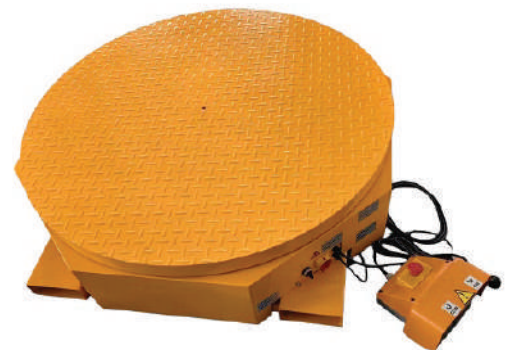

Visit www.mitaco.com.au for more photos and details

Specifications

Model		ERP2000A
Capacity	(kg)	2000
Platform diameter	(mm)	1220
Platform Height	(mm)	306
Speed	(r/min)	2-12
Motor	(kw)	1.1
Wheel	(mm)	Ø252/160
Fork Pocket	(mm)	178x54
Net Weight	(kg)	236

Mitaco has national sales and distribution capabilities, our sales office and warehouse is located in Brisbane. Large inventory holdings enable fast-track dispatch of stock orders. This combined with an easy to use online ordering system makes the delivery of stocked products simple, fast and reliable.