



COMMERCIAL STACK WASHER/DRYER FOR VENDED LAUNDRY APPLICATIONS

CS10EC - CS10GC

WASHER : 9,5KG - DRYER: 8,2KG

FEATURES - WASHER

- **Stainless steel inner and outer drum** for long-lasting worry-free performance
- **Four-compartment soap box** for wash, pre-wash, bleach and softener
- **Dynamic Balancing System**
 - Suspensions & out-of-balance logic manages and redistributes unbalanced loads
 - Quiet operation
- **High-speed extraction**
 - A 1200 RPM extract speed delivers 440G
- **Door opens 180°** for easy loading and unloading
- **Large capacity**
- **Ultra-low water use** of only 51,78 L

FEATURES - DRYER

- **Superior airflow**
 - Fast-drying results with advanced airflow pattern
- **Large capacity**
 - Large 7.0 ct. ft. cylinder
- **Time savings**
 - Large, easy-clean lint filter is located upfront

CONTROL

- **Micro-Display Control (MDC)**
 - Digital display shows vend price
 - Four cycle options
 - Cycle time countdown
 - LED progress indicators



Speak with a Laundry Specialist

t: 1300 222 119 e: info@aqualogic.com.au w: aqualogic.com.au/contact



	CS10EC	CS10GC
MODEL NUMBER	BTEBXASP434AW01	BTGBXASP304AW01
CONTROL	MDC	MDC
CONTROL LOCATION	10° front	10° front
DRUM		
CAPACITY (KG)	washer: 9,5 / dryer: 8,2	washer: 9,5 / dryer: 8,2
CYLINDER VOLUME (L)	washer: 96,8 / dryer: 198	washer: 96,8 / dryer: 198
DRUM SPEED		
G-FORCE	440	440
SPIN SPEED (RPM)	1200	1200
MOTOR		
POWER (KW)	washer : 0,67 / dryer : 0,25	washer : 0,67 / dryer : 0,25
CABINET		
CYLINDER FINISH	washer : stainless steel / dryer: galvanized	washer : stainless steel / dryer: galvanized
COLOUR	white	white
DOOR TYPE	window / window	window / window
HEATING		
HEAT SOURCE	washer: N/A / dryer : electric	washer: N/A / dryer : gas
HEATING POWER	washer: N/A / dryer: 4 000 kW	washer: N/A / dryer: 25 000 BTU
CONNECTION		
GAS INLET CONNECTION (MM)	N/A	9,5
EXHAUST OUTLET DIAMETER (MM)	102	102
EXHAUST AIRFLOW (LITERS/SEC)	105	105
WATER INLET (IN)	0,75	0,75
WATER PRESSURE (BAR)	1,4 / 8,3	1,4 / 8,3
DRAIN	Pump drain	Pump drain
OPERATION		
CYCLES	washer : 5 / dryer : 4	washer : 5 / dryer : 4
CYCLE INDICATOR LIGHTS	yes	yes
POWER		
ELECTRICAL REQUIREMENTS	240V / 50Hz / 1Ph	240V / 50Hz / 1Ph
TRANSPORT DATA		
GROSS WEIGHT (KG)	189	189
NET WEIGHT (KG)	175	175
DIMENSIONS H X W X D (MM)	1986 x 683 x 704	1986 x 683 x 704
PACKING DIMENSIONS H X W X D (MM)	2032 x 762 x 864	2032 x 762 x 864
VOLUME (m ³)	1,34	1,34

* heights may slightly vary, depending on the leveling adjustments

(mm)	A	B	C	D	E	F	G	H	I	J	K	L	M	N	O	P	Q	R	S
CS10C - electric	1678*	1447*	597	213	610	203	391	938*	371*	813*	683	1986*	1184*	52	704	38 with door closed	333*	-	-
CS10C - gas	1678*	1447*	597	213	610	203	391	59	938*	371*	1140*	813*	683	1986	1184	52	704	38 with door closed	333*

* with leveling legs turned into base
Exhaust openings are 102 mm metal ducting

electric

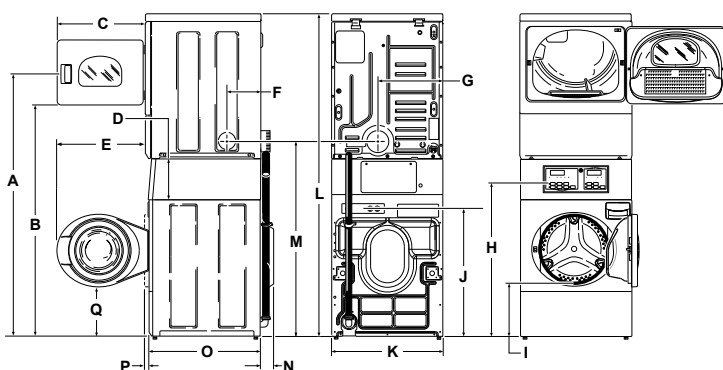

gas

