

High-Speed Horizontal Machining Center for Mass Production Parts

i 50

i 50



i 50

Optimum for Mass Production Machining of Cylinder Head and Cylinder Block

In the automotive parts industry, where 10,000 to 50,000 parts are mass produced every month, automated production systems are essential to accommodate production volume that varies depending on the car model. DMG MORI's i 50 is the ideal machine tool that encompasses all the elements required of line production machines: "compactness," "reliability" and "maintainability."

Designed with structures optimized for cylinder head and cylinder block machining, the i 50 delivers high-speed, high-precision machining, contributing to the development of a safe automobile society.

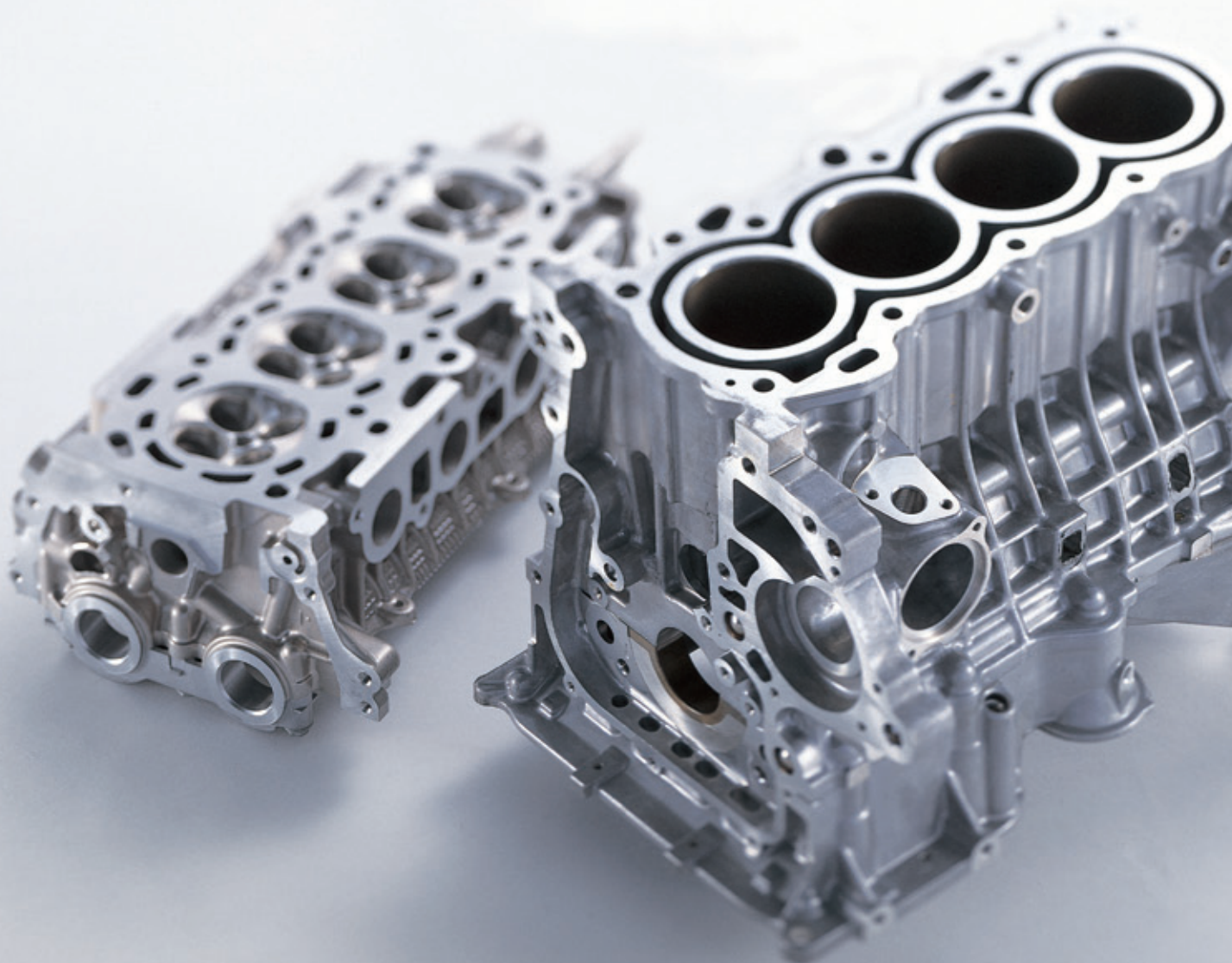



1



2



3



4

Automobiles

1 2 Cylinder head

3 4 Cylinder block

Highlights

- Machine Highlights

Machine and Technology

Others

Machine Specifications

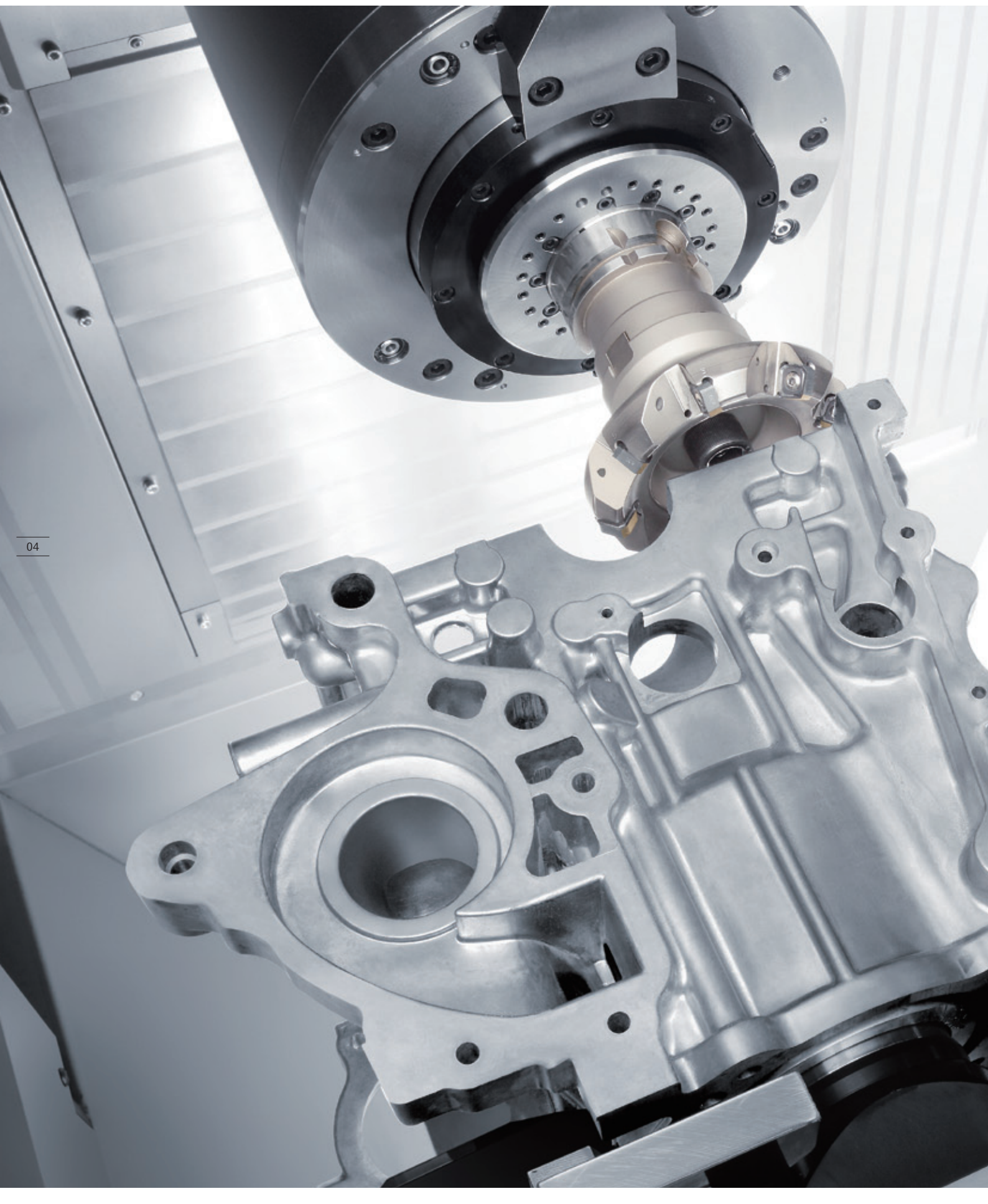

Pursuit of Quality and Efficiency

The i 50 is a space-saving machine without APC. The compact footprint is approximately 6.7 m² (72.1 ft²). The machine height has been lowered to reduce a vertical stroke of the gantry loader, resulting in shorter loader cycle times. The model employs the spindle that moves in three directions (X-, Y-, and Z-axis) and makes the moving unit on the Z-axis lighter, ensuring high-speed feeding: a rapid traverse rate of 62 m/min (2,440.9 ipm) and an acceleration of 1.0 G (Z-axis). The outstanding chip disposal drastically improved by steep internal covers and a center trough structure makes the model ideal for mass-production machining of automotive parts.

Space-saving design

- + Machine size <width × depth × height>:
1,680 × 3,962 × 3,380 mm (66.1 × 156.0 × 133.1 in.)
- + Minimum pitch between machines:
2,090 mm (82.3 in.) <gantry-type loader specification>
- + Highly efficient workpiece transfer system available

High rigidity

- + Light and high-rigidity body is achieved by FEM analysis
- + Bed with higher rigidity made possible by placing the Z-axis drive section at the top of the spindle

FEM: Finite Element Method

High speed

- + Spindle that moves on the three axes and lighter moving parts on the Z-axis
- + Rapid traverse rate: 62 m/min (2,440.9 ipm)

High precision

- + Full closed loop control (Scale feedback) as standard

Reliability

- + Sophisticated spindle labyrinth structure
- + Outstanding chip disposal

Floor space
Approx. 6.7 m²
(72.1 ft²)

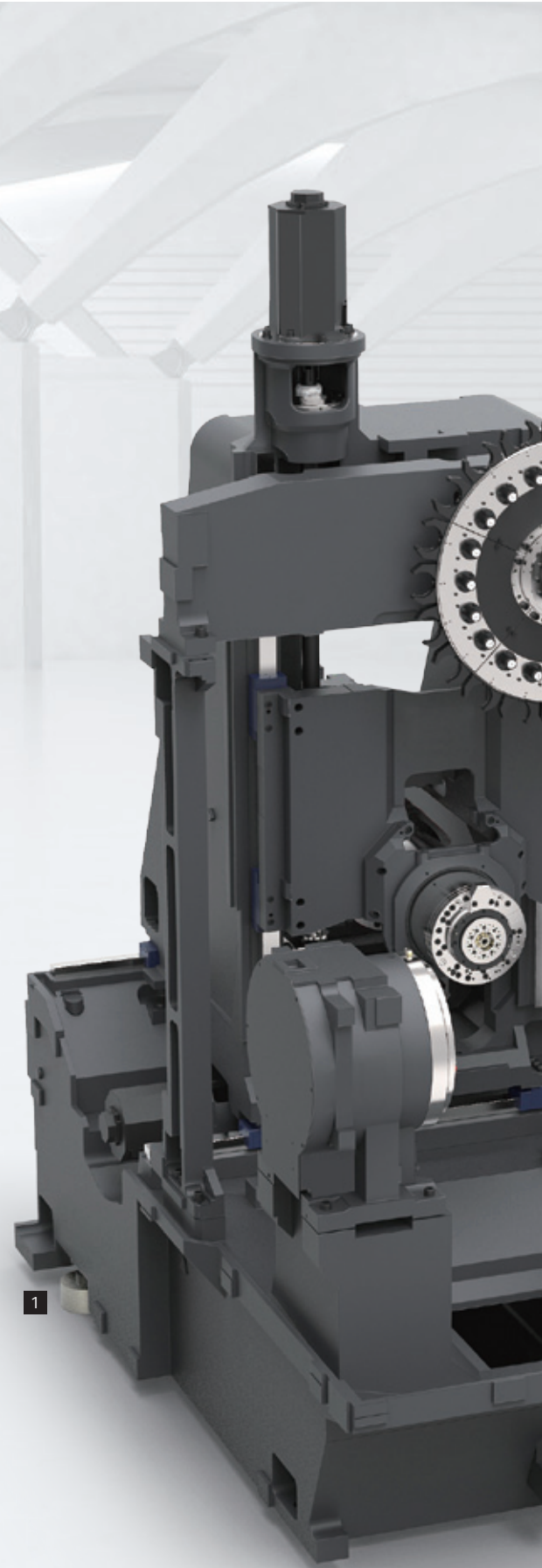
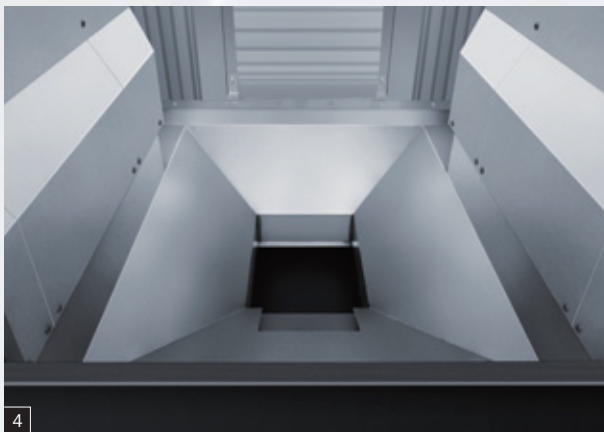
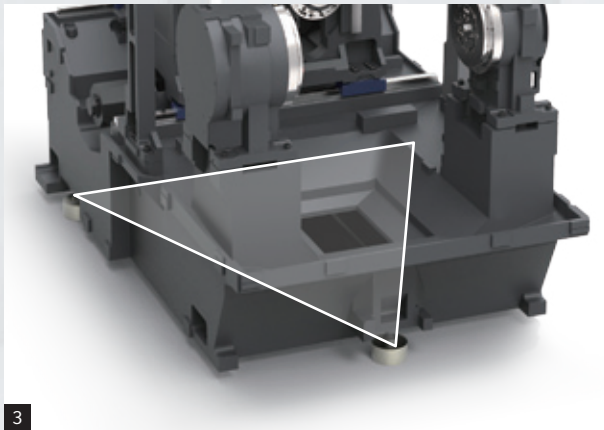
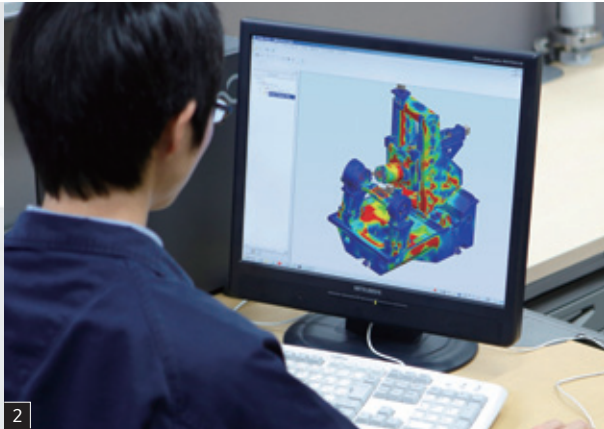

Light yet Robust Construction

DMG MORI conducts FEM analysis at the basic design stage to pursue greater rigidity. The i 50 uses a thick, robust yet lightweight bed to significantly increase the static rigidity of the Z-axis. This ensures rigidity sufficient for spindle movement in the three axis directions, and improves productivity even in cylinder boring that exerts a large cutting reaction force on the Z-axis.

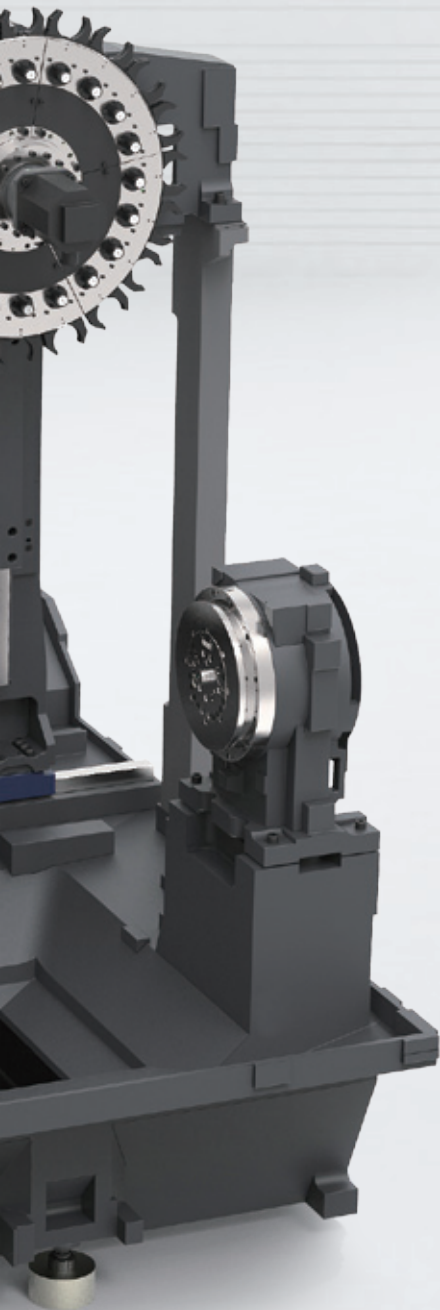

1 High-rigidity bed

- + Locating the Z-axis drive section at the top of the spindle makes the bed thicker, achieving the high rigidity ideal for mass production machining of cylinder heads and cylinder blocks

2 FEM: Finite Element Method

- + Light and high-rigidity body is achieved by FEM analysis

3 3-point support structure

- + The three-point support system makes it easy to perform horizontal adjustments, dramatically reducing installation time
- + Structure not affected by ground conditions or secular change

4 Center trough structure

- + The steep internal covers allow less chip accumulation inside the machine

i 50

Achieve the Ultimate in High-accuracy Machining

The i 50 is equipped with everything required for stable high-precision machining.

In addition to perfect spindle cooling, a highly reliable SmartSCALE (Magnescale) with extreme accuracy is employed on all axes as standard to ensure the best positioning accuracy for a long period of time.

08

Full closed loop control (Scale feedback) as standard on all axes (SmartSCALE)

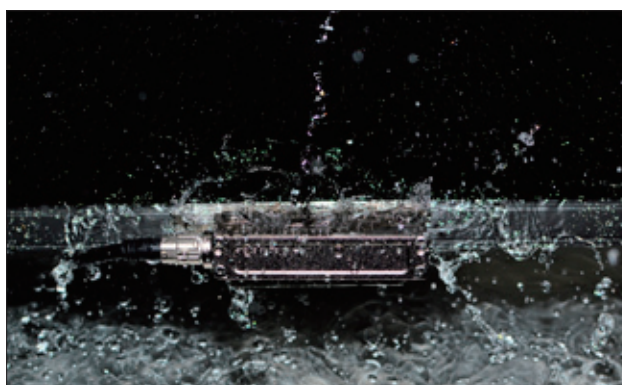

Simple non-contact structure

- + Saves space bearingless compact design
- + Can be mounted in proximity to workpieces, enabling easy installation of multiple scales on one axis



Conventional model



SmartSCALE

High resolution of 0.01 μm

- + Newly developed algorithm employed to improve the high-performance arithmetic processing circuit

No air purge necessary thanks to the sealing structure with a protection degree of IP67

- + The magnetic scale and the detection device surfaces completely covered with a metal cover for even higher durability against coolant and chips

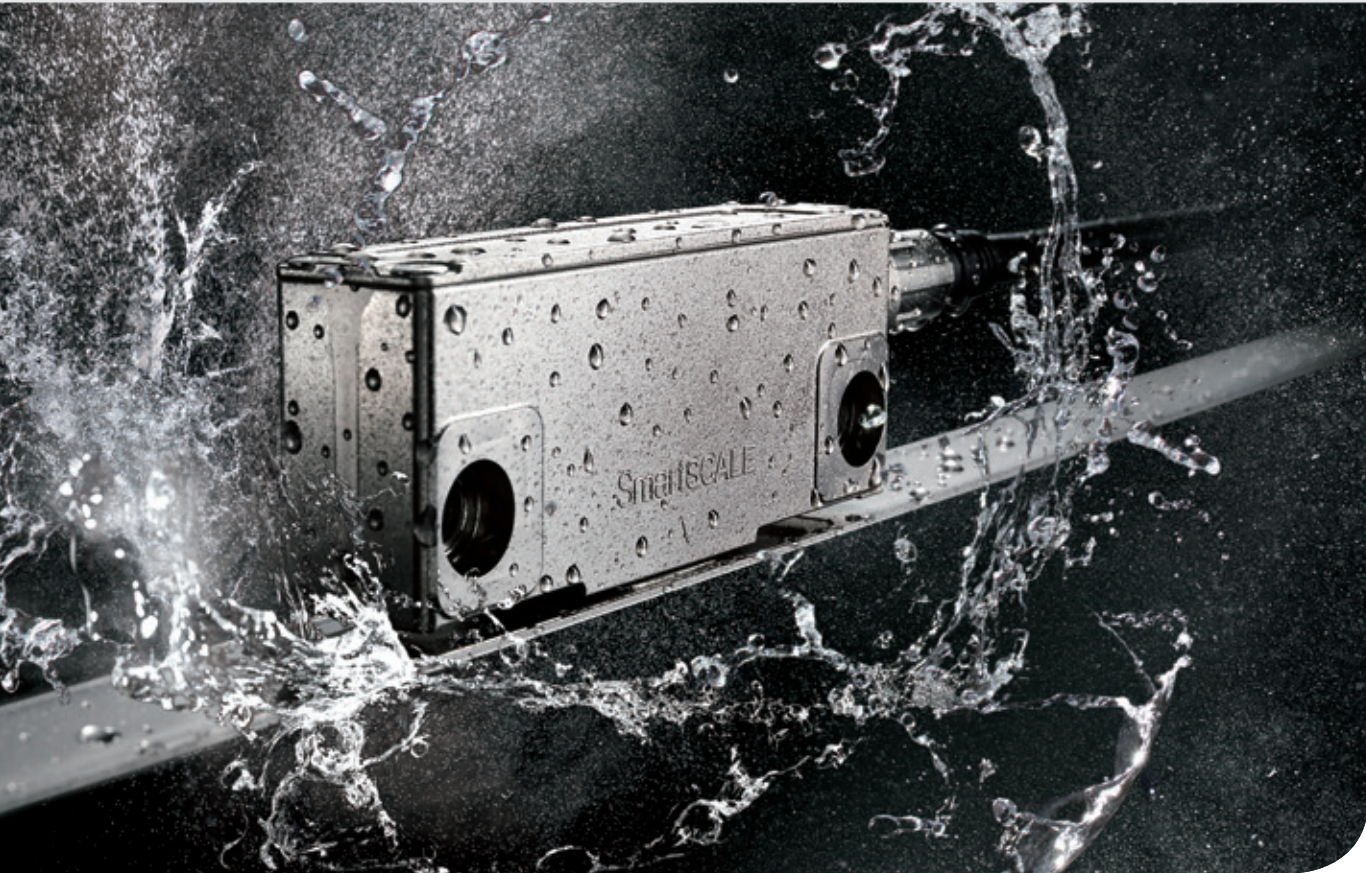

Coolant chiller (separate type) <option>



Increased coolant temperature causes thermal displacement in the fixtures and workpiece, affecting the machining accuracy of the workpiece. Use this unit to prevent the cutting coolant from heating up. When using oil-based coolant, the coolant temperature can become extremely high even with the standard coolant pump, so please be sure to select this unit.

When using oil-based coolant or a high-pressure coolant system, please be sure to consult our sales representative.

- + Machining with required accuracy of less than 20 μm
- + High-precision machining that requires a large amount of high-pressure coolant
- + Machining that requires oil-based coolant

● We cannot guarantee that this unit will completely control the coolant temperature. It is designed to help prevent oil temperature increases.

i 50

Lighter Z-axis Moving Parts for Faster Machining

The i 50 employs the spindle that moves in three directions (X-, Y-, and Z-axis) and the lighter moving unit on the X-axis, ensuring high-speed machining.

The new spindle, speedMASTER, ensures excellent durability, cutting performance and speed.

The machine achieves an acceleration of up to 1.0 G on the Z-axis where a drilling or tapping cycle is repeatedly performed, and spindle acceleration ($0 \rightarrow 12,000 \text{ min}^{-1}$) of 1.0 seconds.

What's more, the machine boasts a rapid traverse rate of 62 m/min (2,440.9 ipm) on all axes, contributing to a significant reduction in machining time.

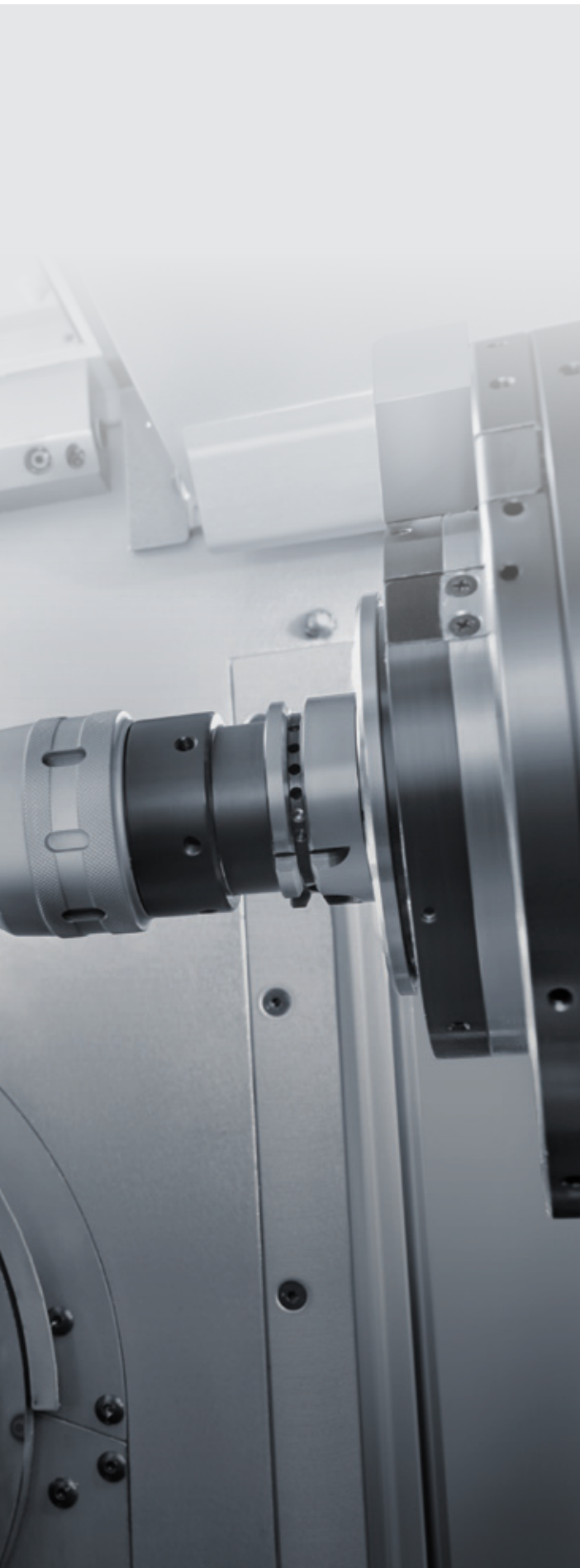

High-speed machining

- + High-speed machining is achieved by employing the spindle which moves along the three axes (X, Y, and Z axes) and lightening the moving parts on the Z-axis
- + Spindle acceleration / deceleration time (0→12,000 min⁻¹ / 12,000 min⁻¹→0): 1.0 sec.
- + Indexing time (A-axis) <90°>: 2.5 sec. (including clamping and unclamping time)
- + Max. acceleration <X- / Y- / Z-axis>: 0.7 / 0.7 / 1.0 G {6.9 / 6.9 / 9.8 m/s² (22.6 / 22.6 / 32.2 ft/s²)}
- + Rapid traverse rate <X, Y and Z axes>: 62,000 mm/min (2,440.9 ipm)

Sophisticated spindle labyrinth structure

- + The labyrinth structure has been enhanced, taking into account frequent use of high-pressure coolant
- + Prevent coolant entry and improve spindle durability

No. 40 taper spindle

- + Type of tool shank: HSK-A63 [KM6350]
- + Max. spindle speed: 15,000 min⁻¹
[20,000 min⁻¹ <high speed>]
- + Output: 37 / 22 kW (50 / 30 HP) <15%ED / cont>
[37 / 18.5 kW (50 / 24.7 HP) <15%ED / cont> (high speed)]
- + Max. spindle torque: 250 N•m (184.4 ft•lbf) <10%ED>
[221 N•m (163.0 ft•lbf) <10%ED> (high speed)]

[] Option

Applications and Parts

Highlights

Machine and Technology

▸ Table

Others

Machine Specifications



DDM (Direct Drive Motor) Equipped as Standard

Three types of table are available to improve the customers' productivity: the A-axis table specification, the B-axis table specification (option), and the AB-axis table specification (option) <consultation required>. The DDM incorporated as standard minimizes vibration, achieving high-precision, high-efficiency machining with no backlash.

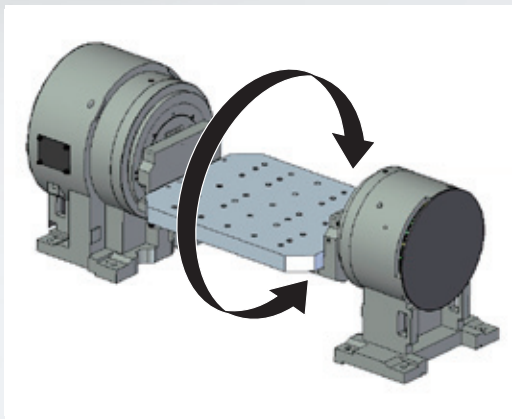

A-axis table

- + Table max. rotational speed: 100 min⁻¹
- + Table indexing time (90°)
<including clamping and unclamping time>:
2.5 sec.



B-axis table (option)

- + Table max. rotational speed: 100 min⁻¹
- + Table indexing time (90°)
<including clamping and unclamping time>:
1.4 sec.

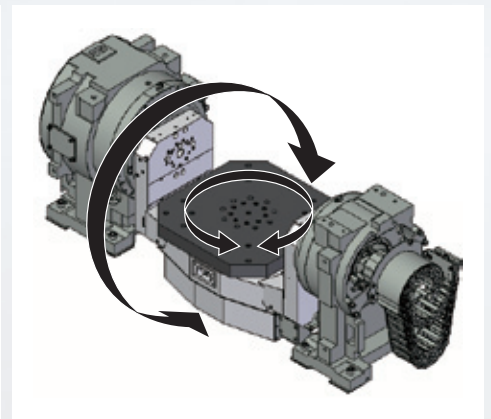

AB-axis table (option) <consultation is required>

- + Table max. rotational speed:
22.5 min⁻¹ (A-axis), 100 min⁻¹ (B-axis)
- + Table indexing time (90°)
<including clamping and unclamping time>:
2.8 sec. (A-axis), 2.8 sec. (B-axis)

• For the fixture & fixture plate to be used, the cradle inertia and the unbalance torque, please consult our sales representative.

DDM: Direct Drive Motor

Working area

	A-axis table	B-axis table (option)	AB-axis table (option) <consultation is required>
Table size mm (in.)	640 × 500 (25.2 × 19.7)	500 × 500 (19.7 × 19.7)	400 × 500 (15.7 × 19.7)
Table loading capacity kg (lb.)	250 (550)	400 (880)	180 (396)
Max. workpiece size* mm (in.)			

* Depending on the fixtures or transfer system to be used, some workpieces may not be machined even when the workpiece size is within the machinable range. Please be sure to consult our sales representative to make sure your workpieces can be machined.

i 50

Compact Magazines

The i 50 offers the 20-tool magazine for smooth and high-speed indexing as standard.

The magazine with up to 40-tool stations is also available as an option.

The tool breakage detector which prevents problems caused by tool breakage is also available as an option to offer even greater reliability.

- + Max. tool length: 320 mm (12.5 in.)
- + Max. tool mass: 12 kg (26.4 lb.) <for the 20-tool storage capacity specification, the total tool mass is up to 120 kg (264 lb.).>
- + Max. tool diameter: 163 mm (6.4 in.) <without adjacent tools> / 90 mm (3.5 in.) <with adjacent tools>
- + Cut-to-cut (chip-to-chip): 3.3 sec.

- Depending on the arrangement of tools in the magazine, the cut-to-cut (chip-to-chip) time may be longer.

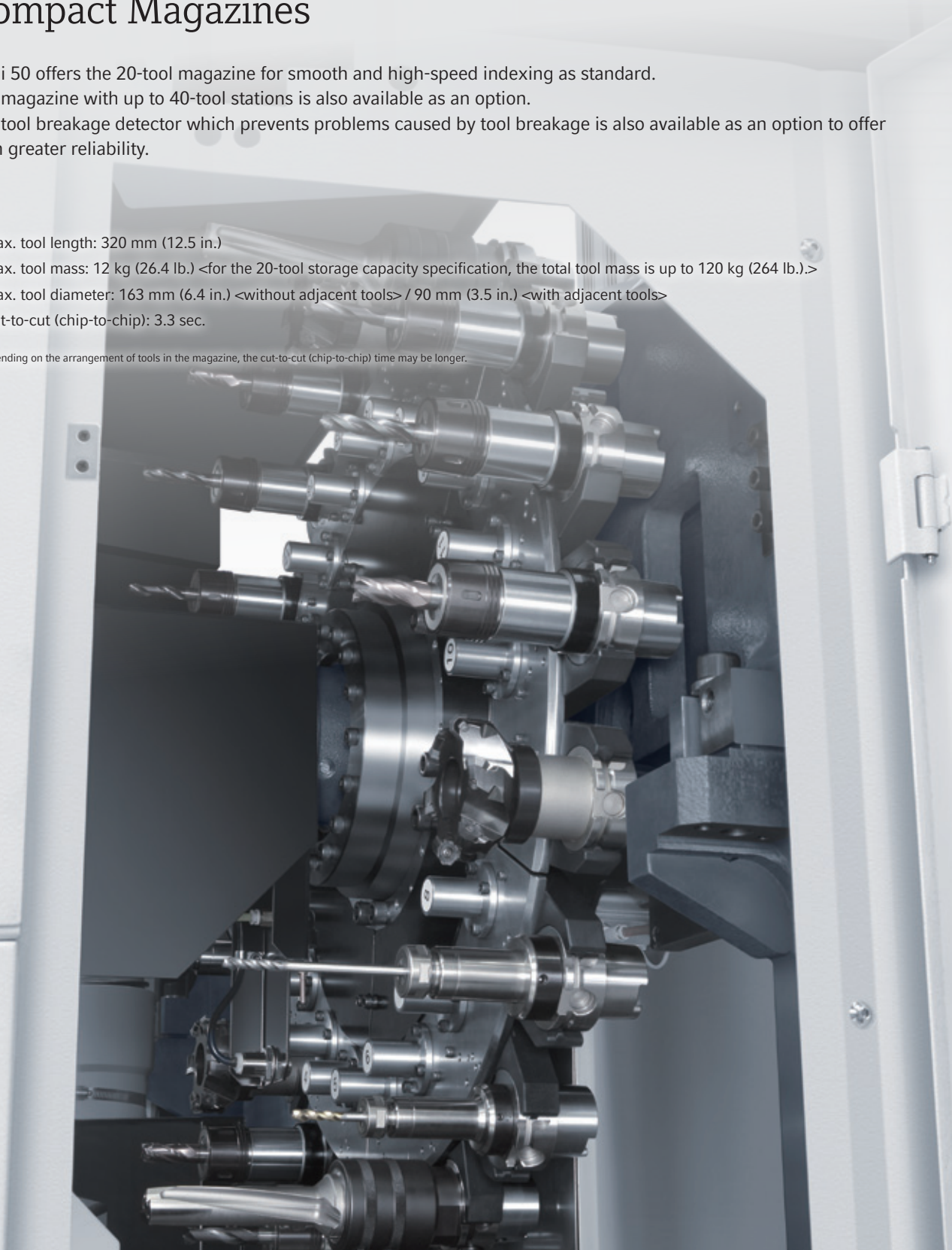



Spindle direct tool change method

When tools need changing, the spindle moves up to the height of the magazine to pick up tools. The machine width is reduced as the tool magazine is mounted on the upper part of the machine.

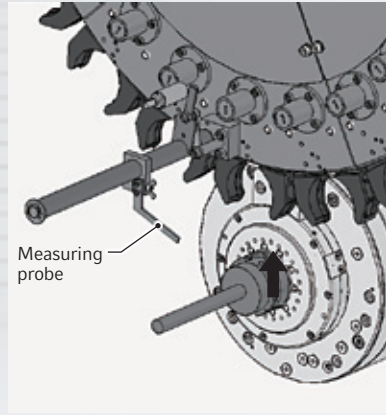

Tool breakage detection system <magazine> (option)

When the tool returns to the standby position it pushes the measuring probe up. A broken tool will not push the probe up, and this is how breakage is detected.

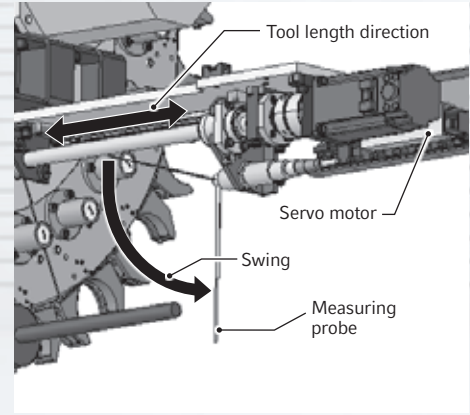

Servo-motor-driven tool breakage detection system <magazine> (option)*

When the tool returns to the magazine side from the spindle, the measuring probe swings to the tool tip to check breakage. If breakage is detected, the system gives an alarm and stops the machine to prevent trouble in advance. The servo motor drive enables the measuring probe to move according to the length of the tool used, making it possible to check various types of tools.

* Not applicable to the gantry loader specification or 40-tool magazine specification.

Chip disposal

Chip conveyor (external)

+ A high-performance external chip conveyor that takes up little space and is easy to maintain is equipped as standard.



Workpiece material and chip size	○: Suitable —: Not suitable				
	Steel		Cast iron	Aluminum / non-ferrous metal	
	Long	Short	Short	Long	Short
Scraper type + drum filter type (standard)	—	○	○	—	○
Magnet scraper type (consultation is required)	—	○	○	—	○

- [Chip size guidelines] Short: chips 100 mm (3.9 in.) or less in length, bundles of chips ϕ 50 mm (ϕ 2.0 in.) or less
Long: bigger than the above
- The options table shows the general options when using coolant. Changes may be necessary if you are not using coolant, or depending on the amount of coolant, compatibility with machines, or the specifications required.
- Please select a chip conveyor to suit the shape of your chips. When using special or difficult-to-cut material (chip hardness HRC45 or higher), please consult our sales representative.
- Chip conveyors are available in various types for handling chips of different shape and material. For details, please consult our sales representative.



Steep internal covers

Center trough structure

- + The steep internal covers allow less chip accumulation inside the machine
- + It prevents chip-causing problems and shortens cleaning time to lighten the work load for operators
- + It also enables long-term automatic operation, making the machine ideal for line production

i 50

Pursuit of Usability

The i 50 comes with many features to enhance ease of use. It employs a double sliding door in a compact design to boost operating efficiency.

Additionally, the hydraulic unit and other peripherals requiring periodic maintenance are placed in an easily accessible location to facilitate maintenance and inspection.

This ensures the machine is always in the best condition, thereby bringing greater productivity to the customer.





Wide door opening

A double sliding door is used, ensuring a wide door opening. This enables smooth setup operations such as adjustment of the fixture.



Touch screen operation panel

Operating convenience has been improved with a touch screen operation panel.

Centralized layout of devices



1 Hydraulic valves (with oil pan)



2 Air components (filter, regulator, etc.)



3 Water-glycol heat exchanger



4 Lubricating oil pump

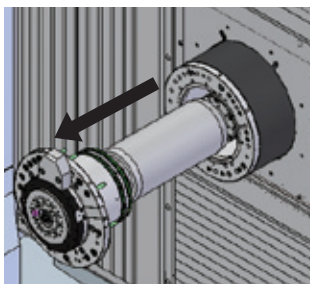

Replacement of spindle unit

The cartridge type built-in motor spindle can be replaced as a set without removing all the wiring and piping.

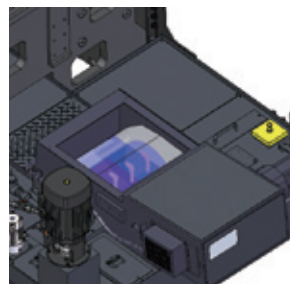

Cleaning / Replacing the Drum Filter

A lid immediately above the filter can be removed for maintenance without having to pull the chip conveyor out to the rear of the machine.

i 50

Solutions Best Matched to Customers' Needs

With its compact body width of 1,680 mm (66.1 in.), the i 50 provides the perfect solution to a customers' issue on installation space that often arises at the time of establishment of automated lines. The gantry loader specification, which ensures the smallest possible maintenance space between machines, enables establishment of mass production lines in a space-saving footprint. The cover shape can be flexibly changed to various types such as the manual transfer type and the automatic transfer type according to customers' needs.



- + Machine width: 1,680 mm (66.1 in.)
- + Maintenance space between machines: 600 mm (23.6 in.)
- + Minimum pitch between machines: 2,090 mm (82.3 in.) <gantry-type loader specification>

Fully automated machining process



Pick up rough cylinder block from workpiece conveyor

After picking up the rough cylinder from the conveyor, the gantry loader unloads a finished component from the first machine.



Gantry-type loader

Cylinder block unloading through an overhead door.



Automatic clamping fixture

After loading by the gantry loader, the fixture automatically clamps the cylinder block.

Production line dedicated for cylinder blocks consists of five i 50s, two arm type gantry loaders, a cleaning unit and a workpiece transfer conveyor



Reduction in loader cycle times

Height of the ceiling cover above the table of only 1,955 mm (77.0 in.) and shorter gantry loader travel contribute to shortening non-cutting times

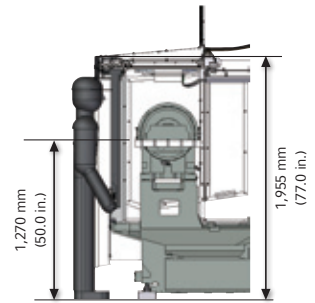

Loader shutter opening

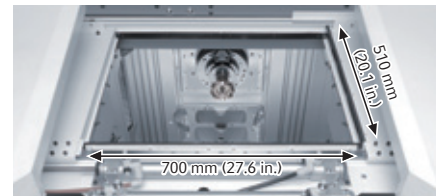

Manual transfer (roller conveyor specification) <consultation is required>

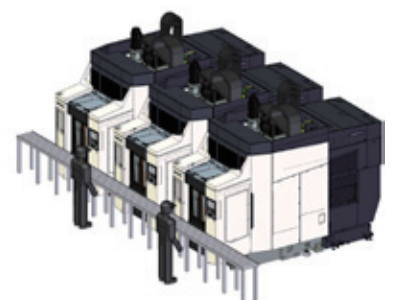

Horizontal cylinder bore machining

After tilting the A-axis table automatically, cylinder block boring follows.



Washing station

Washing the finished cylinder block and unloading onto the conveyor.

i 50

COMPACT*line* Suitable for Mass Production Machining

The COMPACT*line*, a simple and compact operation system, is equipped with various helpful functions, allowing the operators to customize display contents according to machining situations.

- + 4-window display for checking necessary machine information all at once
- + Customizable machine information on the 4-window display according to customers' needs
- + Improved setups by displaying necessary machine information according to operation
- + Enhanced workability by displaying machine information and machine operation buttons on one touch panel
- + Compact design for space-saving



Reduction in Environmental Burden

To conserve limited resources and protect global environment. The i 50 pursues a high "environmental performance" that is required of machine tools.

When the latest DMG MORI horizontal machining center "NHX 4000 2nd Generation" and the "SH-403" manufactured in 2002 are compared, the annual power consumption can be reduced by approximately 34%*.

*The effect indicated above may not be achieved depending on the machines, cutting conditions, environmental conditions at measurement.

Power-saving Functions

- + If the screen is not touched for a certain amount of time and NC operation is not being performed, power is cut off to the servo motor, the spindle, the coolant pump and the chip conveyor, thereby saving energy.
- + The latest, energy-efficient components with low power consumption and LED lighting are employed
- + The positioning speed is automatically adjusted in accordance with the spindle acceleration / deceleration time to achieve optimal acceleration / deceleration control

Reduced Cycle Times

- + The next M-code command can be specified before the previous command is completed. This enables multiple operations to be overlapped, resulting in shorter cycle times
- + The number of pecking operations in a deep hole drilling cycle is automatically controlled according to the cutting load, shortening the machining time

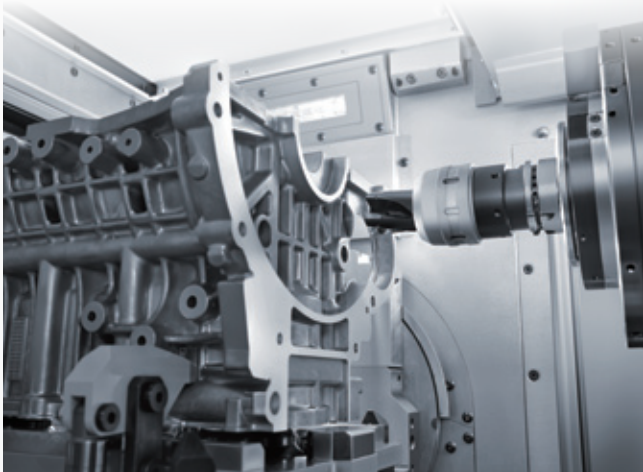

i 50

Machine Size

mm (in.)

A-axis table, B-axis table

Front view

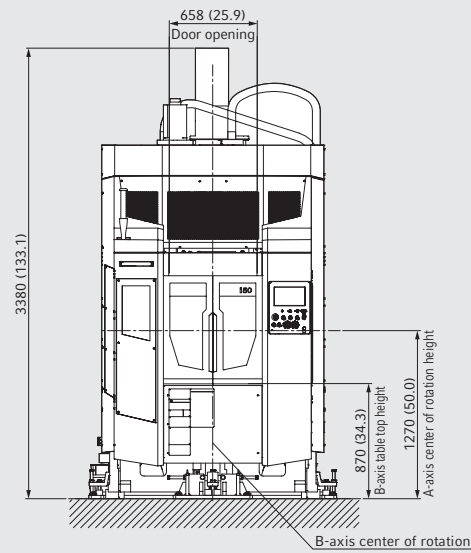

Side view

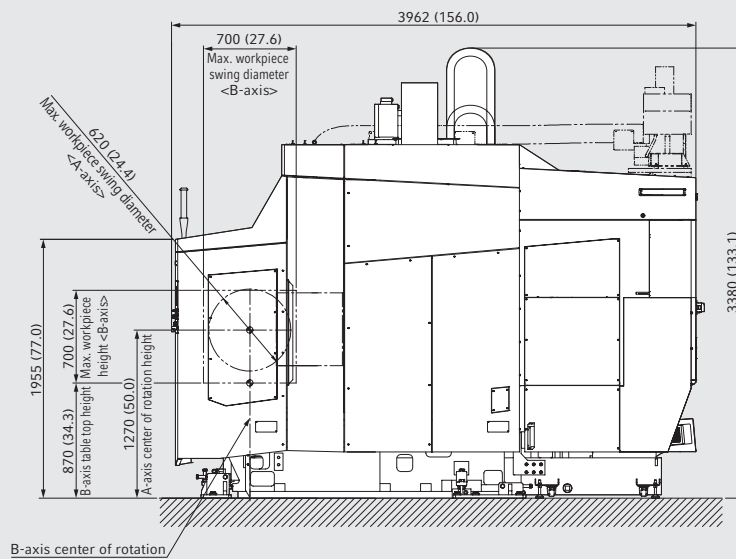

Machine Specifications

			i 50
Travel			
X-axis travel <longitudinal movement of column>	mm (in.)		500 (19.7)
Y-axis travel <vertical movement of saddle>	mm (in.)		550 (21.7)
Z-axis travel <cross movement of spindle head>	mm (in.)		500 (19.7)
A-axis travel			360° [75° to -150°*1]
B-axis travel			[360°]
Table			
Working surface	A-axis	mm (in.)	640 × 500 (25.2 × 19.7)
	B-axis	mm (in.)	[500 × 500 (19.7 × 19.7)]
	AB-axis	mm (in.)	[400 × 500 (15.7 × 19.7)]
Table loading capacity <including fixtures>	A-axis	kg (lb.)	250 (550)
	B-axis	kg (lb.)	[400 (880)]
	AB-axis	kg (lb.)	[180 (396)]
Max. workpiece swing diameter*2	A-axis	mm (in.)	620 (24.4)
	B-axis	mm (in.)	[700 (27.5)]
	AB-axis	mm (in.)	[610 (24.0)]
Table indexing time (90°) <including clamping and unclamping time>	A-axis	s	2.5
	B-axis	s	[1.4]
	AB-axis	s	[2.8 <A-axis, B-axis>]
Spindle			
Max. spindle speed	min ⁻¹		15,000 [20,000]
Feedrate			
Rapid traverse rate	mm/min (ipm)		X, Y, Z: 62,000 (2,440.9)
Cutting feedrate	mm/min (ipm)		X, Y, Z: 0—62,000 (0—2,440.9) <when using look-ahead control>
ATC			
Type of tool shank			HSK-A63 [KM6350 <two-face contact>]
Tool storage capacity			20 [40]
Max. tool diameter	With adjacent tools	mm (in.)	90 (3.5)
	Without adjacent tools	mm (in.)	163 (6.4)
Max. tool length	mm (in.)		320 (12.5)
Max. tool mass	kg (lb.)		12 (26.4)*3
Motor			
Spindle drive motor <15%ED / cont>	kW (HP)		37 / 22 (50 / 30) [37 / 18.5 (50 / 24.7) <20,000 min ⁻¹ >]
Machine size			
Machine height <from floor>	mm (in.)		3,380 (133.1)
Floor space <width × depth>	mm (in.)		1,680 × 3,962 (66.1 × 156.0)
Mass of machine	kg (lb.)		9,680 (21,296)
Control unit			
FANUC			F32iB

[] Option

*1 When the AB-axis table is selected.

*2 Depending on the fixtures or transfer system to be used, some workpieces may not be machined even when the workpiece size is within the machinable range. Please be sure to consult our sales representative to make sure your workpieces can be machined.

*3 For the 20-tool storage capacity specification, the total tool mass is up to 120 kg (264 lb.).

● Indexing time may change depending on fixtures and fixture plates to be used and cradle inertia.

● For the fixture & fixture plate to be used, the cradle inertia and the unbalance torque, please consult our sales representative.

● Max. spindle speed: depending on restrictions imposed by the workpiece clamping device, fixture and tool used, it may not be possible to rotate at the maximum spindle speed.

● Machine size: the actual values may differ from those specified in the catalogue, depending on the optional features and peripheral equipment.

● For details, please check the Detailed Specifications.

● The information in this catalog is valid as of February 2018.

Standard & Optional Features

●: Standard
 ○: Option
 ☆: Consultation is required

Spindle		
Type of tool shank	HSK-A63	●
	KM6350 (two-face contact)	○
15,000 min ⁻¹ : 37 / 22 kW (50 / 30 HP) <15%ED / cont>		●
20,000 min ⁻¹ : 37 / 18.5 kW (50 / 24.7 HP) <15%ED / cont>		○
Table		
Table (for the fixture & fixture plate to be used, the cradle inertia and the unbalance torque, please consult our sales representative)	A-axis table	●
	B-axis table	○
	AB-axis table	☆
Magazine		
Tool storage capacity	20 tools	●
	40 tools	○
Coolant		
Coolant system	Water-soluble	●
Coolant chiller (separate type)		○*1
Coolant chiller (through-spindle coolant system)		○*1
Through-spindle coolant system (center through)	1.5 MPa (217.5 psi) <unit on coolant tank>	●*1
	3.5 MPa (507.5 psi) <separate type>	○
	7.0 MPa (1,015 psi) <separate type>	○
Mist collector SMG-40		○
Chip disposal		
Chip conveyor (external)	Scraper type + drum filter type	●
	Magnet scraper type	☆
Measurement		
In-machine measuring system (spindle)*2	Touch sensor (radio signal transmission type)*3 (M)	○
Improved accuracy		
Full closed loop control (Scale feedback)		●
Automation		
Automatic door		○
Other		
Signal lamp	4 colors (LED type: red, yellow, green, blue)	○
Manual pulse generator (separate type)		●

*1 DMQP (DMG MORI Qualified Products)

*2 The specifications vary depending on the manufacturers. (M: made by MARPOSS)

*3 Please note that there are a few countries where the radio signal transmission type cannot be used because no radiowave license in those countries has been obtained yet. For details, please consult our sales representative.

- For details, please check the Detailed Specifications.
- The information in this catalog is valid as of February 2018.
- Specifications, accessories, safety device and function are available upon request.
- Some options are not available in particular regions. For details, please consult our sales representative.

⚠ Flammable coolant such as oil-based coolant has a high risk of ignition, and will cause fire or machine breakage if ignited. If you have to use a flammable coolant for any reason, please be sure to consult our sales representative.

<Precautions for Machine Relocation>

EXPORTATION:

All contracts are subject to export permit by the Government of Japan.
Customer shall comply with the laws and regulations of the exporting country governing the exportation or re-exportation of the Equipment, including but not limited to the Export Administration Regulations.
The Equipment is subject to export restrictions imposed by Japan and other exporting countries and the Customer will not export or permit the export of the Equipment anywhere outside the exporting country without proper government authorization.
To prevent the illegal diversion of the Equipment to individuals or nations that threaten international security, it may include a "Relocation Machine Security Function" that automatically disables the Equipment if it is moved following installation.
If the Equipment is so-disabled, it can only be re-enabled by contacting DMG MORI or its distributor representative. DMG MORI and its distributor representative may refuse to re-enable the Equipment if it determines that doing so would be an unauthorized export of technology or otherwise violates applicable export restrictions.
DMG MORI and its distributor representative shall have no obligation to re-enable such Equipment.
DMG MORI and its distributor representative shall have no liability (including for lost profits or business interruption or under the limited service warranty included herein) as a result of the Equipment being disabled.

+ DCG, DDM, ORC, speedMASTER, powerMASTER, 5X-torqueMASTER, ZEROCHIP, CELOS, ERGOline, SLIMline, COMPACTline, DMG MORI SMARTkey, DMG MORI gearMILL and 3D quickSET are trademarks or registered trademarks of DMG MORI CO., LTD. in Japan, the USA and other countries.

- + If you have any questions regarding the content, please consult our sales representative.
- + The information in this catalog is valid as of February 2018. Designs and specifications are subject to changes without notice.
- + The machines shown in the catalog may differ from the actual machines. The location and the size of the nameplates may also differ from the actual machines, or the nameplates may not be attached to some machines.
- + DMG MORI is not responsible for differences between the information in the catalog and the actual machine.

DMG MORI CO., LTD.

Nagoya Head Office ☐ 2-35-16 Meieki, Nakamura-ku, Nagoya City, Aichi 450-0002, Japan Phone: +81-52-587-1811
Tokyo Global Headquarters ☐ 2-3-23, Shiomis, Koto-ku, Tokyo 135-0052, Japan Phone: +81-3-6758-5900

Iga Campus ☐ 201 Midai, Iga City, Mie 519-1414, Japan Phone: +81-595-45-4151
Nara Campus ☐ 362 Idono-cho, Yamato-Koriyama City, Nara 639-1183, Japan Phone: +81-743-53-1121

The logo for DMG MORI, with "DMG" in green and "MORI" in red, both in a bold, sans-serif font.