

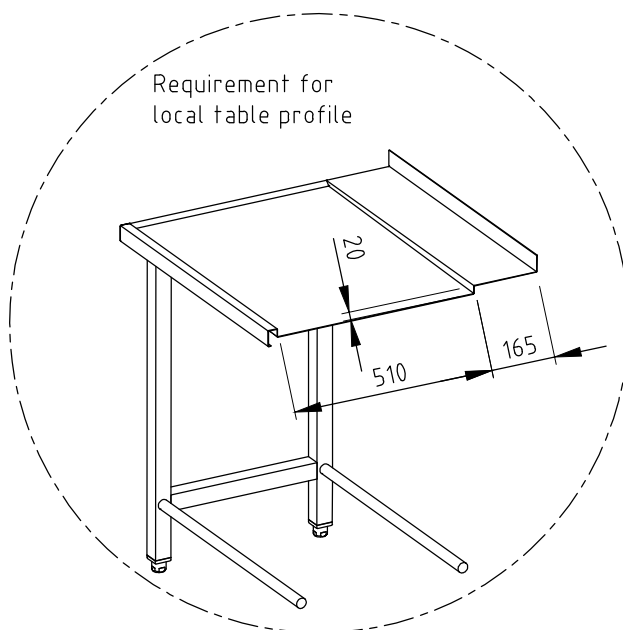

1.0	machine connection: Drain line hose fitted as odour trap in interior of machine	DN 22
1.1	drain (max. 750 mm above of the floor level)	DN 50
2.0	machine connection: fresh water line	G 3/4"
2.1	soft warm water 45 - 60°C max. 0,54 mmol/l CaCO <sub>3</sub> / 53,4 ppm/CaCO <sub>3</sub> (max.3°GH) approx. water flow rate 4 l/min min. flow pressure: 60 kPa / 0,6 bar upstream of the solenoid valve, maximum pressure: 500 kPa / 5 bar stopcock and fine screen ≤ 25 μm	DN 15
		G 3/4 a
3.0	machine connection: electricity connecting cable	5G 2,5mm <sup>2</sup>
3.1	electricity supply to the machine	3N PE 400V ~ 50Hz
	nominal current / - capacity	17.2 A 8.5 kW
	⊕ Voltage equalising cable	Fuse protection: 20 A
Electrical equipment suitable for supply voltage: 3N PE 380-415 V 50 Hz / 1N PE 220-240 V 50 Hz		
heat load of the wash room in case of 20 program cycles /h	total	ca. 2.1 kW
	perceptible	ca. 1.4 kW
	latent	ca. 0.7 kW
all cables, pipes etc leaving machine		1,6 m
the position of the connection piping can also be mirror-inverted		
Options available on machine		
(A) Entry height		
Rinse agent pipe and suction lance (blue connector)		
Detergent pipe and suction lance		
Booster pump		
Drain pump		
AirBox ActiveAir (vapour treatment)		
feeding table on site		
discharge table on site		
	Recommended suction area according to German VDI 2052 or any local regulations have to be observed to determine ventilation of wash areas	

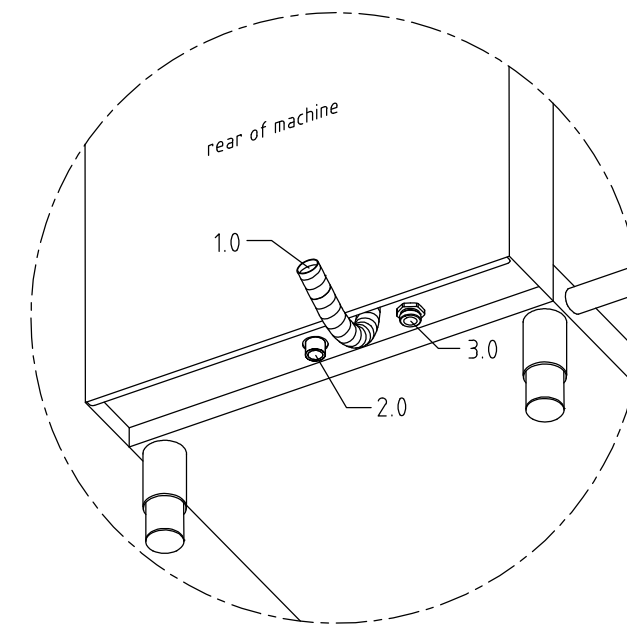
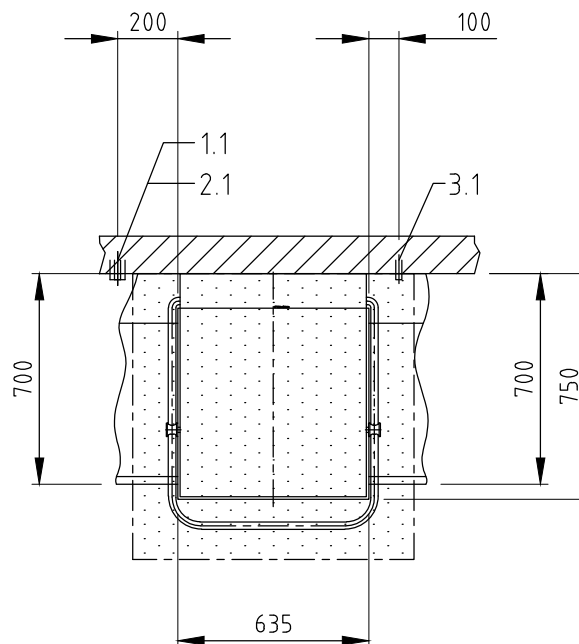
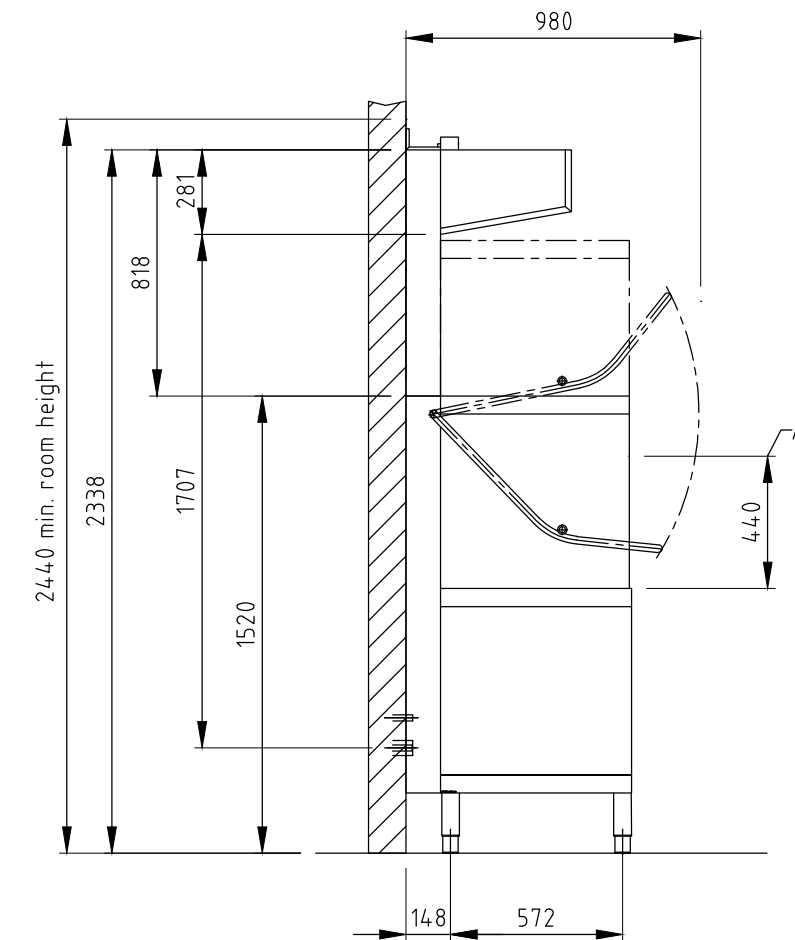
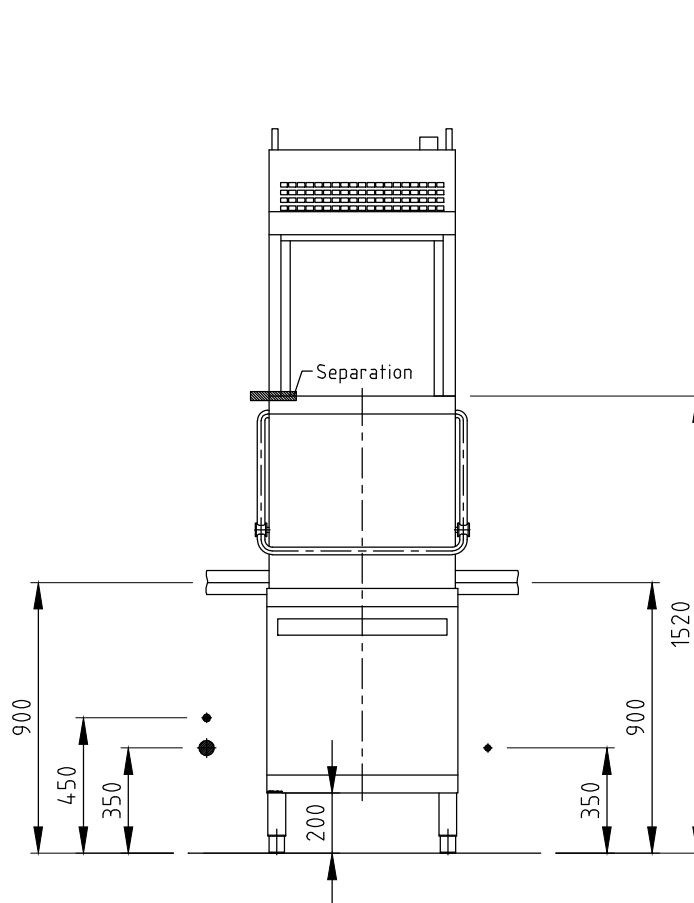

 MEIKO Australia-Pacific Pty Ltd Unit 4, 72 - 74 Gibbes Street Chatswood NSW 2067 TEL. +61-1300 367 730, Telefax +61-1300 656 420 E-MAIL: info@meiko.com.au	Revision	
	Reference	DISHWASHER STANDARD DRAWING / AUS
It is neither allowed to give this drawing without our permission to a third party for information or reproduction, nor may it be used for competition purposes. We reserve all rights! Please note: This document is only valid in conjunction with the conditions defined in the document "Important remarks"! Can be requested from the manufacturer or downloaded from Partnernet.	Drawing-No.	S00008368
	Scale	1:25
	drawn:	22.06.2017 m-iplan
	checked:	22.06.2017 mja
	Type	UPSTER H 500
	Order-No.	