

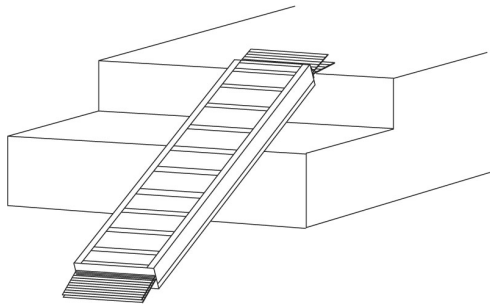

1. Maximum weight limit is **800 pounds**.
2. Read and follow all instructions before use.
3. Do not use if ramp is damaged or unstable.
4. Ramp is shipped fully assembled.
5. Place ramp on landing in the folded position and ensure that the top lip (labeled TOP) is resting securely on the landing (DIAGRAM 1).
6. Unfold ramp and center on landing (DIAGRAM 1 & 2).
7. **SAFETY & MAINTENANCE:** Regularly check ramp for damage, and check and tighten any loose fasteners. Keep ramp surface clear of ice, snow, dirt, leaves, and other debris. For snow/ice, remove accumulation and sweep the surface clean. To remove dirt, leaves, and other debris, sweeping the surface or using a garden hose will usually suffice, but, if needed, use a damp cloth or soft brush with non-alkaloid detergent and water. Rinse well and use extra caution if ramp surface is wet.
8. **OPTIONAL FEATURE:** Increase the usefulness of the SUITCASE® Signature Series™ Ramp with the Top Lip Extension (TLE). This optional extension increases the standard 3" lip to become 9", allowing the ramp to clear the rear bumper of SUVs and vans by simply attaching to the top lip of the ramp (diagram 4). TLE is for use with unoccupied mobility equipment only and, when used, reduces the overall ramp weight capacity to 500 pounds. Contact your local retailer or visit [www.ezaccess.com](http://www.ezaccess.com) for details.

- ⚠ **WARNING:** Ensure that the top lip is secure before using ramp. We recommend attaching the ramp temporarily to the landing using the provided clevis pins (drill 1/4" hole in landing) or semi-permanently using screws through the pre-drilled holes at the top of each section (DIAGRAM 2). To prevent ramp from becoming dislodged during use, ensure that the top lip overlaps the resting surface as far as possible.
- ⚠ **WARNING:** The surface holding the top lip needs to be substantial; make sure that the surface and supporting structure is of sound construction.
- ⚠ **WARNING:** Ramp may be slippery when wet or icy.
- ⚠ **WARNING:** Use only with a qualified helper and always use your lap belt.
- ⚠ **WARNING:** The ramp shown in diagrams (below) is the 5-ft length. To select the ramp length, an incline chart is provided on the reverse side of this document. However, it is intended only as a guideline. Refer to your equipment's (wheelchair or scooter) Owner Guide for the proper degree of incline/decline and chair direction before attempting ramp use. Never exceed its recommendations.



**DIAGRAM 1**

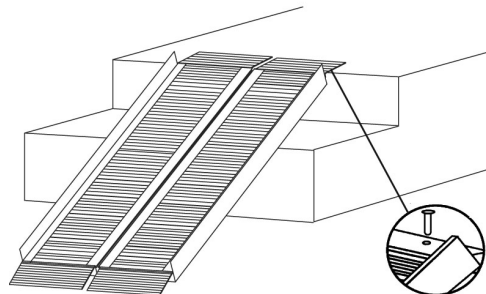

**DIAGRAM 2**

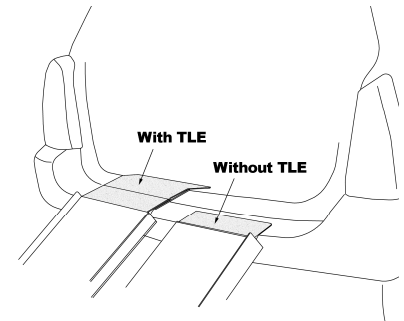

**DIAGRAM 3**

- ✂
1. EZ-ACCESS, a division of Homecare Products, Inc., herein referred to as Manufacturer, warrants that equipment is free from defects in material and workmanship under normal use and service. This limited warranty is non-transferable and applies to original owner, effective for a period of 3-years from the date of original retail purchase (original dated purchase receipt is required) and applies to metal structure only (excludes powder coated finish and applied non-skid tread). No part of this warranty will apply to any equipment which has been subject to misuse, vandalism, negligence, alteration, accident, improper installation, or which has been repaired outside Manufacturer's place of business in any way as in the reasonable judgment of Manufacturer, to adversely affect its performance and reliability, nor to normal deterioration due to wear, tear and exposure, corrosion, damage caused by rain, fire, earthquake or other natural causes or acts of nature.
  2. The attached registration card must be mailed within 10-days of purchase. Manufacturer's obligation under this warranty is limited to repairing or replacing, at its option, equipment which is returned to Manufacturer's place of business with a return authorization number (SEE #4 FOR DETAILS) and which, upon examination, shall disclose to Manufacturer reasonable satisfaction to have been thus defective. Manufacturer will make the repair or replacement of defective parts under this warranty without charge for parts or labor.
  3. If Manufacturer finds that any equipment has not provided the warranted service life, Manufacturer will, as its sole obligation and the user's sole remedy for breach of this warranty, repair or replace the unit, at its option, for a charge prorated on the following basis. The user will be allowed a credit against the list price of equivalent equipment at the time of return to Manufacturer, in proportion to the percentage of the warranted service life remaining at the time of return to Manufacturer. Purchaser will be responsible to pay the balance of the list price of equivalent equipment; and Manufacturer reserves the right to require payment prior to delivery of the repaired/replacement equipment. Manufacturer's whole warranty responsibilities are summarized below (return shipping/delivery charges to be paid by the Purchaser). NOTE: In calculating available credit, the remaining warranted service life is rounded up or down to the nearest whole year. YEARS 0-1: Unit repaired or replaced; YEARS 1-2: Repair or 50% \$ credit (current list price multiplied by credit percentage); YEARS 2-3: Repair or 25% \$ credit (current list price multiplied by credit percentage).
  4. If Purchaser discovers a defect, he/she must call Manufacturer at 253-249-1101 to request an RA# to return, at his/her own expense, the merchandise to Manufacturer. Prior to returning product, digital images of merchandise (close-up of defect, plus photo of overall product) must be submitted (an email address will be provided at the time an RA# is given). The duration of any implied warranty of merchantability or fitness for a particular purpose shall be limited in all respects to the duration of the limited warranty and the warranty described above shall be in lieu of any other express warranty. Some states do not allow limitation on how long an implied warranty will last so the above limitation may not apply to you. Manufacturer neither assumes nor authorizes any other person to assume for it any other liability in connection with Manufacturer.
  5. The buyer's sole and exclusive remedy against the Manufacturer shall be for the repair or replacement of defective merchandise as provided above. No other remedy, including but not limited to, incidental or consequential damages for lost profits, lost sales, injury to property, or any other incidental or consequential loss shall be available to him/her. Labor to remove, ship, and/or reinstall ramp is not covered by manufacturer's warranty. Because some states do not allow the exclusion or limitation of incidental or consequential damages, the above limitation or exclusion may not apply to you. Before using, user shall determine the suitability of the product for its intended use and user assumes all risk and liability whatsoever in connection therewith.
  6. This warranty gives you specific legal rights. You may also have other rights, which vary from state-to-state.



# INCLINE CHART



		RAMP LENGTH								
		2'	3'	4'	5'	6'	7'	8'	9'	10'
RISE	3"	7.2°	4.8°	3.6°	2.9°	2.4°	2.0°	1.8°	1.6°	1.4°
	4"	9.6°	6.4°	4.8°	3.8°	3.2°	2.7°	2.4°	2.1°	1.9°
	5"	12°	8.0°	6.0°	4.8°	4.0°	3.7°	3.0°	2.7°	2.4°
	6"	14.5°	9.6°	7.2°	5.7°	4.8°	4.1°	3.6°	3.2°	2.9°
	7"		11.2°	8.4°	6.7°	5.6°	4.8°	4.2°	3.7°	3.3°
	8"		12.8°	9.6°	7.7°	6.4°	5.5°	4.8°	4.2°	3.8°
	9"		14.5°	10.8°	8.6°	7.2°	6.2°	5.4°	4.8°	4.3°
	10"			12.0°	9.6°	8.0°	6.8°	6.0°	5.3°	4.8°
	12"			14.5°	11.5°	9.6°	8.2°	7.2°	6.4°	5.7°
	14"				13.5°	11.2°	9.6°	8.4°	7.4°	6.7°
	16"					12.8°	11.0°	9.6°	8.5°	7.7°
	18"					14.5°	12.4°	10.8°	9.6°	8.6°
	20"						13.8°	12.0°	10.7°	9.6°
	22"							13.2°	11.8°	10.6°
	24"							14.5°	12.8°	11.5°
	26"								13.9°	12.5°
	28"								15.0°	13.5°
30"									14.5°	

**IMPORTANT:** Refer to your equipment's (wheelchair or scooter) User Guide for exact recommendations concerning acceptable usage and incline/decline.

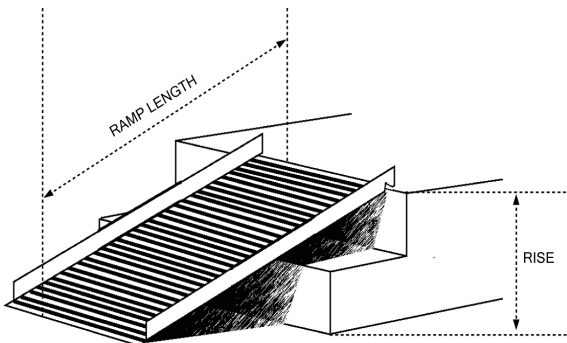

## TO ESTABLISH THE PROPER RAMP LENGTH:

- Determine the incline that your chair is designed to climb.
- Measure the rise (distance from the top step, porch, van, etc. to the ground).
- Refer to Incline Chart to find proper ramp length.
- At any incline, use ramp only with a qualified helper.



## WARRANTY REGISTRATION

EZ-ACCESS®, A DIVISION OF HOMECARE PRODUCTS, INC. • 1704 B ST NW STE 110 • AUBURN WA 98001-1650

PRODUCT	STOCK NUMBER
NAME	PHONE
ADDRESS	CITY, ST, ZIP
NAME OF DEALER	DEALER'S CITY, ST, ZIP
PRICE	DATE PURCHASED
COMMENTS	
WHAT INFLUENCED YOUR PURCHASE OF THIS PRODUCT?	
<input type="checkbox"/> SAW IN STORE <input type="checkbox"/> RECOMMENDATION OF FRIEND <input type="checkbox"/> RECOMMENDATION OF DEALER <input type="checkbox"/> MAGAZINE AD <input type="checkbox"/> OTHER (PLEASE EXPLAIN):	

WARRANTY IS NOT VALID UNLESS POSTMARKED WITHIN 10 DAYS OF PURCHASE