

1	1	WT121206	1200x1200 Welding Table Top	
2	2		100mm Rebound Polyurethane Wheel 150kg Capacity Castor Fixed	
3	2		100mm Rebound Polyurethane Wheel 150kg Capacity Castor Swivel	
4	2		LEG ASSEMBLY-CASTOR OPTION LH	
5	2		LEG ASSEMBLY-CASTOR OPTION RH	
6	16	NNYL116Z	M16 NYLOC NUT (ZINC)	
7	16	FA116040Z	M16 x 40 HEX BOLT (ZINC)	
8	16	NNYL108Z	M8 NYLOC NUT (ZINC)	
9	32	WFLT08Z	M8 FLAT WASHER (ZINC)	
10	16	FA108025Z	M8 x 25 HEX BOLT (ZINC)	
ITEM	QTY	DRAW/MATL No.	TITLE/MATERIAL	CHECK BOX
PARTS LIST				

FABRICATION TOLERANCE <small>Unless otherwise specified</small>		
LINEAR	RANGE	TOL.
	0-100	± 0.5
	101-300	± 1.0
	>301	± 2.0
ANGULAR		±0.5
<small>UNITS IN MM, IF IN DOUBT ASK</small>		

APOLLO ENGINEERING
 47 BARNES STREET
 TAMWORTH NSW 2340
 TELEPHONE: (02) 6765 7353 FAX: (02) 6765 3612

DRAWN T.M	MASS N/A	DATE 8/04/2024	TITLE 1200x1200 WELDING TABLE ASSEMBLY			
DO NOT SCALE - REFER ALL QUERIES TO APOLLO ENGINEERING Pty Ltd ALL DIMENSION IN MILLIMETERS UNLESS OTHERWISE NOTED THIS DRAWING IS THE PROPERTY OF APOLLO ENGINEERING IT MUST NOT BE COPIED OR LOANED WITHOUT THE WRITTEN CONSENT OF THE COMPANY, AND MUST BE RETURNED UPON REQUEST.			FABRICATION			
			APOLLO_WELD TABLE			
SCALE N.T.S	SIZE A3	DRAWING No	SHEET 1 / 2	REV		

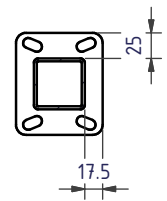

SECTION B-B

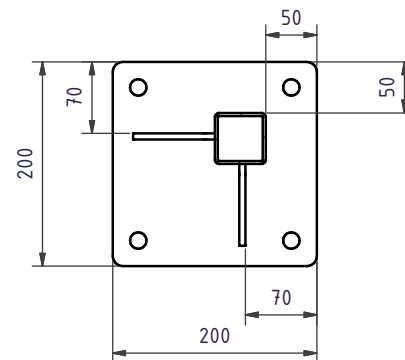
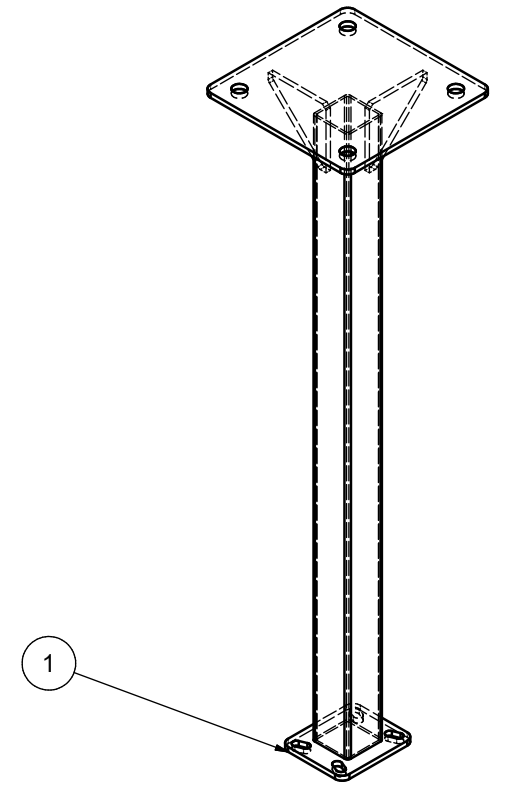
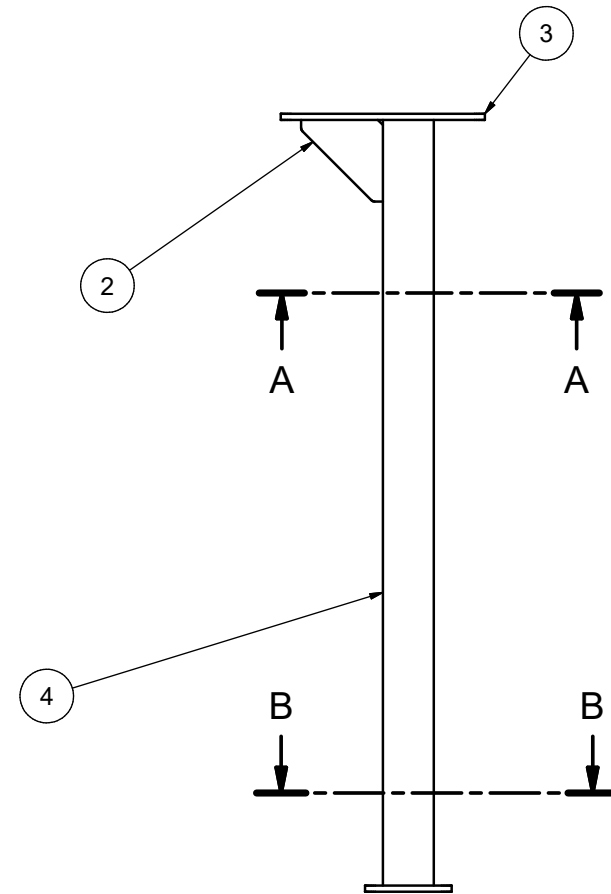

SECTION A-A

NOTE,
 REQUIRE 2 LH & 2 RH
 RH SHOWN

ITEM	QTY	MATL PART No.	DESCRIPTION	LENGTH
4	1	SH3-50508	50 x 50 x 3 SHS	750
3	1	PL06-315	150 x 6 250G BLACK	150
2	2	PL06-315	80 x 6 250G BLACK	80
1	1	PL06-315	85 x 6 250G BLACK	100
PARTS LIST				

FABRICATION TOLERANCE <small>Unless otherwise specified</small>		
LINEAR	RANGE	TOL.
	0-100	± 0.5
	101-300	± 1.0
	>301	± 2.0
ANGULAR		± 0.5
<small>UNITS IN MM, IF IN DOUBT ASK</small>		

APOLLO ENGINEERING
 47 BARNES STREET
 TAMWORTH NSW 2340
 TELEPHONE: (02) 6765 7353 FAX: (02) 6765 3612

DRAWN T.M	MASS 5.8 kg	DATE 8/04/2024
<small>DO NOT SCALE - REFER ALL QUERIES TO APOLLO ENGINEERING Pty Ltd ALL DIMENSION IN MILLIMETERS UNLESS OTHERWISE NOTED</small>		
<small>THIS DRAWING IS THE PROPERTY OF APOLLO ENGINEERING IT MUST NOT BE COPIED OR LOANED WITHOUT THE WRITTEN CONSENT OF THE COMPANY, AND MUST BE RETURNED UPON REQUEST.</small>		

TITLE LEG ASSEMBLY-CASTOR OPTION RH			
FABRICATION			
APOLLO_WELD TABLES			
SCALE N.T.S	SIZE A3	DRAWING No	SHEET 2/2
		REV	