



## Dimensions

Height	4 340mm (without hopper)
Width	2 320mm
Depth	2 410mm
Weight	7 650 Kg
Feed Width	1234 x 1080mm
Roto Knives	3 x 2

## Performance

Power Supply	415V 3 Phase
Motor	132 kW
Shaft Speed	414rpm

## Features

- Hardened steel rotor knives
- Material sizing screens
- Auto Reverse Protection
- Easy Maintenance
- Reliable & Durable Construction
- Control Panel
- Generous Loading Aperture

## Optional Extras

- Sound Proof Enclosure
- Various Rotors for different plastics
- In-Feed & Out-feed Conveyors
- Out-Feed Extraction Units
- Outfeed screw loaders
- Custom hopper design



Dimensions and technical information without obligation. Subject to change.

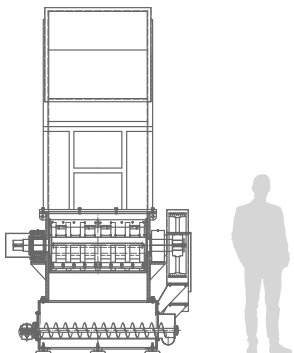
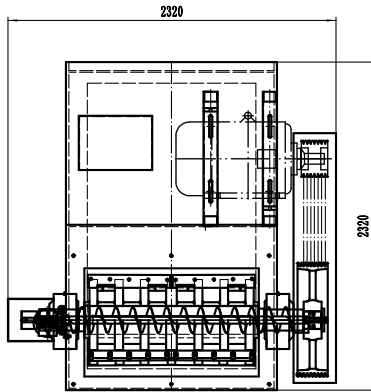
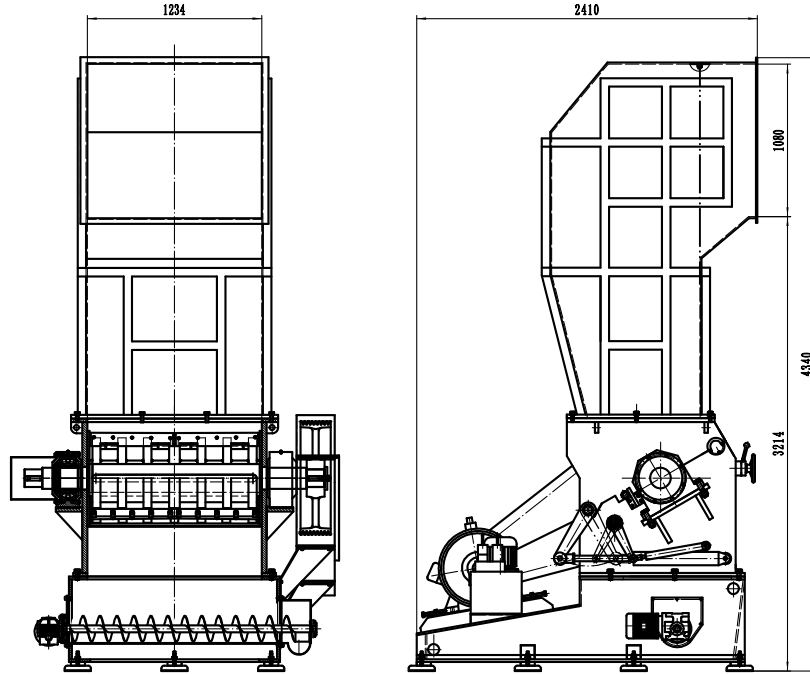

Size Comparison



**Safety**  
E-Stops, AS Standards, Interlocked doors



**Motor**  
132kW



**Waste Types**  
Mixed Plastics, HDPE, PET, Mixed Fabric, E-waste ...

