

# SSL-50

LIGHTING TOWER



## Specifications

Height Stowed	2.23 m
Length Stowed	1.47 m
Stowed Width	0.90 m
Weight	700 kg
Max. Height Elevated	5.00 m
Wind Speed Rating	100 km/hr

## Power

Light	1 x 50 W LED
Solar Panel	160 W
Battery	Lithium
Run Time	55+ Hours
Mast Operation	Hand Winch

## Standard Features

- Motion detection lighting—Saves power by dropping light output to 30% when no motion is sensed.
- Dusk-til-Dawn Light Switch
- Rotating Tilttable Solar panel for optimum charging
- Forklift Pockets
- Crane Lifting Point
- Efficient crank winch inside lockable cover
- Light on/off switch for storage



# SSL-50

## LIGHTING TOWER



### Dimensions

All dimensions are approximate.

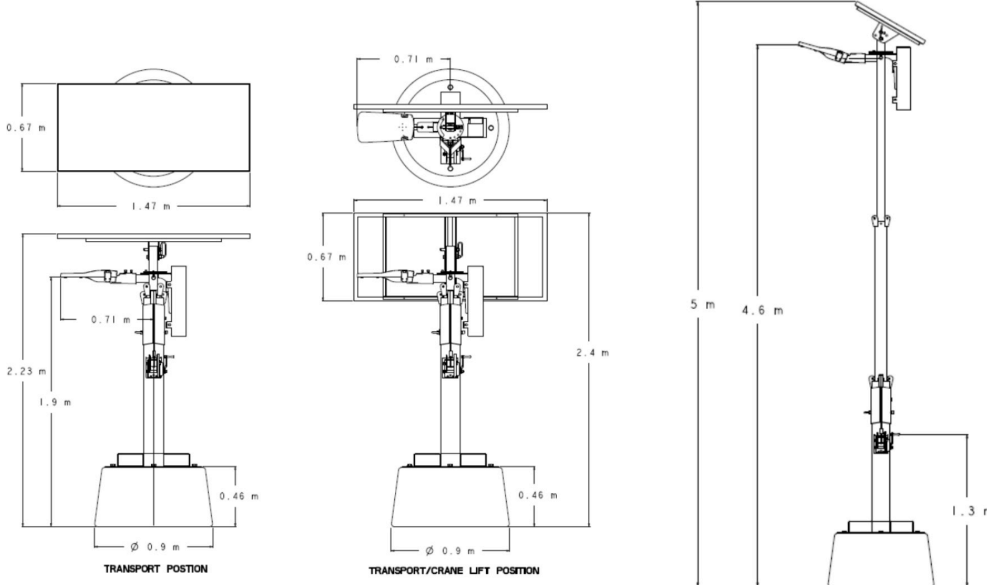

### Isolux Plot

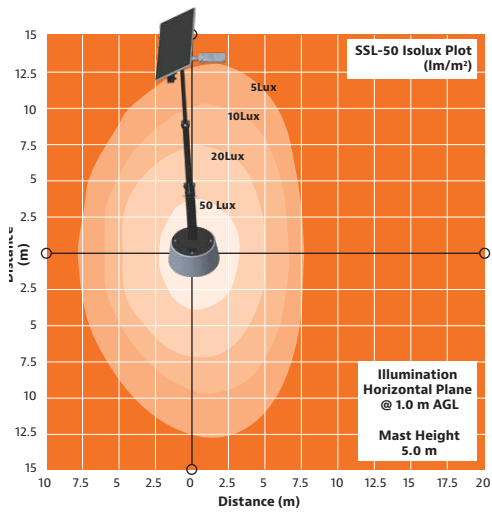

### The JLG "1 & 5" Warranty

The JLG "1 & 5" Warranty JLG Industries, Inc. backs its products with its exclusive "1 & 5" Warranty. We provide coverage on all products for one (1) full year and cover all specified major structural components for five (5) years. Due to continuous product improvements, we reserve the right to make specification and/ or equipment changes without prior notification.

R0524

**JLG Industries (Australia)**  
 358 Park Road  
 Regents Park, NSW 2143  
 Telephone 02 8718 6300  
 Fax 02 8718 6377  
[www.jlg.com.au](http://www.jlg.com.au)

**An Oshkosh Corporation Company**