

Frontload Washers

Metered Commercial

Installation/Operation

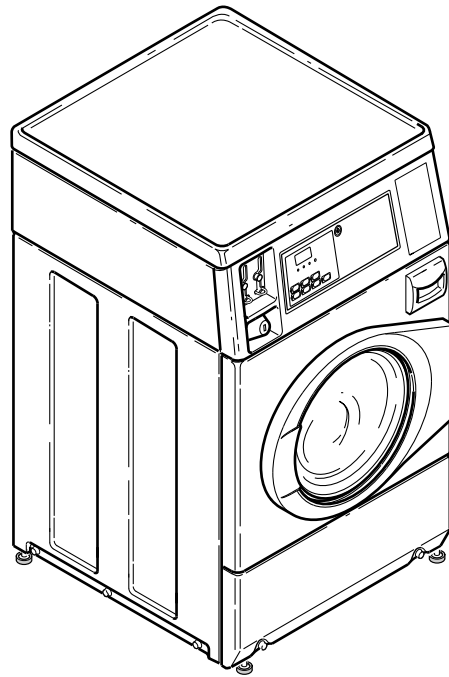

FLW1542C_SVG

Original Instructions

Keep These Instructions for Future Reference.

CAUTION: Read the instructions before using the machine.

(If this machine changes ownership, this manual must accompany machine.)

AllianceTM
Laundry Systems

www.alliancelandry.com

Part No. 805414ENR3
February 2019

	WARNING
<p>Failure to install, maintain, and/or operate this machine according to the manufacturer's instructions may result in conditions which can produce bodily injury and/or property damage.</p>	
W030	

	CAUTION
<p>Changes or modifications not expressly approved could void your authority to use this equipment.</p>	
W965	

	WARNING
<p>For your safety and to reduce the risk of fire or an explosion, do not store or use gasoline or other flammable vapors and liquids in the vicinity of this or any other appliance.</p>	
W022	

This device complies with Part 15 of the FCC Rules. Operation to the following two conditions: (1) This device may not cause harmful interference, and (2) this device must accept any interference received, including interference that may cause undesired operation.

INDUSTRY CANADA STATEMENT

This device complies with Industry Canada licence-exempt RSS standard(s). Operation is subject to the following two conditions: (1) this device may not cause interference, and (2) this device must accept any interference, including interference that may cause undesired operation of the device. The 807211 Wireless Network Control Assembly maintains a separation distance greater than or equal to 2.5 cm which is intrinsic to the installation as described in this manual.

NOTE: The WARNING and IMPORTANT instructions appearing in this manual are not meant to cover all possible conditions and situations that may occur. It must be understood that common sense, caution, and carefulness are factors which cannot be built into these washers. These factors MUST BE supplied by the person(s) installing, maintaining, or operating the unit.

Always contact the distributor, service agent, or the manufacturer about any problems or conditions you do not understand.



Read all instructions before using unit.

This product uses FreeRTOS V7.2.0 (www.freertos.org).

Models with Wireless Board Installed

Through Serial No. 1901xxxxx

This device is granted for use in Mobile only configurations in which the antennas used for this transmitter must be installed to provide a separation distance of at least 20cm from all person and not be co-located with any other transmitters except in accordance with FCC and Industry Canada multi-transmitter product procedures.



Starting Serial No. 1902xxxxx

FCC COMPLIANCE STATEMENT

Table of Contents



Safety Information.....	6
Explanation of Safety Messages.....	6
Important Safety Instructions.....	6
Dimensions and Specifications.....	8
Installation.....	10
Before You Start.....	10
Tools.....	10
Order of Installation Steps.....	10
Position Unit Near Installation Area.....	10
Remove Shipping Materials.....	10
Connect Fill Hoses.....	11
Water Supply Requirements.....	11
Connecting Hoses.....	12
Risers.....	12
Drain Hose Models - Connect Drain Hose to Drain Receptacle.....	13
Standpipe Installation.....	13
Gravity Drain Models - Connect Drain Outlet to Drain System.....	14
Position and Level the Washer.....	14
Wipe Out Inside of Wash Drum.....	15
Supply Injection Models Only - Connect External Supplies to Washer.....	15
Control Function Test.....	16
Plug In the Washer.....	16
Electrical Requirements.....	16
Earth/Ground Instructions.....	17
Check Installation.....	18
Operation.....	19
Operation Instructions.....	19
Load Laundry.....	19
Close Loading Door.....	19
Add Laundry Supplies.....	19
Set Cycle.....	20
Set Wash Temperature.....	20
Set Soil Level.....	20
Insert Coins or Card.....	20
Start Washer.....	21
Indicator Lights.....	21

Maintenance.....	22
User-Maintenance Instructions.....	22
Lubrication.....	22
Cold Weather Care.....	22
Care of Your Washer.....	22
Cleaning Glass Sealing Area.....	22
Replacing Hoses.....	22
Filter Screens.....	22
Extended Non-Use.....	22
Cleaning Foreign Object Trap.....	22
Reinstallation of Shipping Materials.....	23
 Troubleshooting.....	 24
 Contact Information.....	 26
 Installer Checklist.....	 27

Safety Information

Explanation of Safety Messages

Precautionary statements (“DANGER,” “WARNING,” and “CAUTION”), followed by specific instructions, are found in this manual and on machine decals. These precautions are intended for the personal safety of the operator, user, servicer, and those maintaining the machine.

	DANGER
Indicates an imminently hazardous situation that, if not avoided, will cause severe personal injury or death.	
	WARNING
Indicates a hazardous situation that, if not avoided, could cause severe personal injury or death.	
	CAUTION
Indicates a hazardous situation that, if not avoided, may cause minor or moderate personal injury or property damage.	

Additional precautionary statements (“IMPORTANT” and “NOTE”) are followed by specific instructions.

IMPORTANT: The word “IMPORTANT” is used to inform the reader of specific procedures where minor machine damage will occur if the procedure is not followed.

NOTE: The word “NOTE” is used to communicate installation, operation, maintenance or servicing information that is important but not hazard related.

Important Safety Instructions

Save These Instructions

	WARNING
To reduce the risk of fire, electric shock, serious injury or death to persons when using your washer, follow these basic precautions:	
W023	

- Read all instructions before using the washer.
- Install the washer according to the INSTALLATION INSTRUCTIONS. Refer to the EARTH/GROUND INSTRUCTIONS in the INSTALLATION manual for the proper earth/ground connection of the washer. All connections for water, drain, electrical power and earth/ground must comply with local codes and be made by licensed personnel when required. Do not do it yourself.
- Do not install or store the washer where it will be exposed to water and/or weather.
- Do not wash articles that have been previously cleaned in, washed in, soaked in, or spotted with gasoline, dry-cleaning solvents, or other flammable or explosive substances as they give off vapors that could ignite or explode.
- Do not add the following substances or textiles containing traces of the following substances to the wash water: gasoline, kerosene, waxes, cooking oils, vegetable oils, machine oils, dry-cleaning solvents, flammable chemicals, thinners or other flammable or explosive substances. These substances give off vapors that could ignite, explode or cause the fabric to catch on fire by itself.
- Under certain conditions, hydrogen gas may be produced in a hot water system that has not been used for two weeks or more. HYDROGEN GAS IS EXPLOSIVE. If the hot water system has not been used for such a period, before using a washing machine or combination washer-dryer, turn on all hot water faucets and let the water flow from each for several minutes. This will release any accumulated hydrogen gas. THE GAS IS FLAMMABLE, DO NOT SMOKE OR USE AN OPEN FLAME DURING THIS TIME.
- To reduce the risk of an electric shock or fire, DO NOT use an extension cord or an adapter to connect the washer to the electrical power source.
- Do not allow children to play on or in the washer. Close supervision of children is necessary when the washer is used near children. This appliance is not intended for use by persons (including children) with reduced physical, sensory or mental capabilities, or lack of experience and knowledge, unless they have been given supervision or instruction concern-

ing the use of the appliance by a person responsible for their safety. This is a safety rule for all appliances.

- Cleaning and user maintenance shall not be made by children without supervision.
- Children less than three years should be kept away unless continuously supervised.
- Do not reach into the washer if the washtub or agitator, if applicable, is moving.
- Never operate the washer with any guards, panels and/or parts removed or broken. DO NOT tamper with the controls or bypass any safety devices.
- DO NOT operate individual units if they have been separated from a stack unit.
- Use your washer only for its intended purpose, washing clothes. Always follow the fabric care instructions supplied by the garment manufacturer.
- Always read and follow manufacturer's instructions on packages of laundry and cleaning aids. To reduce the risk of poisoning or chemical burns, keep them out of the reach of children at all times (preferably in a locked cabinet). Heed all warnings or precautions.
- Do not use fabric softeners or products to eliminate static unless recommended by the manufacturer of the fabric softener or product.
- Loading door MUST BE CLOSED any time the washer is to fill, tumble or spin. DO NOT bypass the loading door switch by permitting the washer to operate with the loading door open.
- Be sure water connections have a shut-off valve and that fill hose connections are tight. CLOSE the shut-off valves at the end of each wash day.
- Keep your washer in good condition. Bumping or dropping the washer can damage safety features. If this occurs, have your washer checked by a qualified service person.
- Do not repair or replace any part of the washer, or attempt any servicing unless specifically recommended in the user-maintenance instructions or in published user-repair instructions that you understand and have the skills to carry out. ALWAYS disconnect the washer from electrical supply before attempting any service.
- Disconnect the power cord by grasping the plug, not the cord. If the supply cord is damaged, it must be replaced by the manufacturer, its service agent or similarly qualified persons in order to avoid a hazard.
- Before the washer is removed from service or discarded, remove the lid or door to the washing compartment.
- Failure to install, maintain, and/or operate this washer according to the manufacturer's instructions may result in conditions which can produce bodily injury and/or property damage.

NOTE: The WARNING and IMPORTANT SAFETY INSTRUCTIONS appearing in this manual are not meant to cover all possible conditions and situations that may occur. Observe and be aware of other labels and precautions that are located on the machine. They are intended to provide instruction for safe use of the machine. Common sense, caution and care must be exercised when installing, maintaining, or operating the washer.

Always contact your dealer, distributor, service agent or the manufacturer about any problems or conditions you do not understand.

Dimensions and Specifications

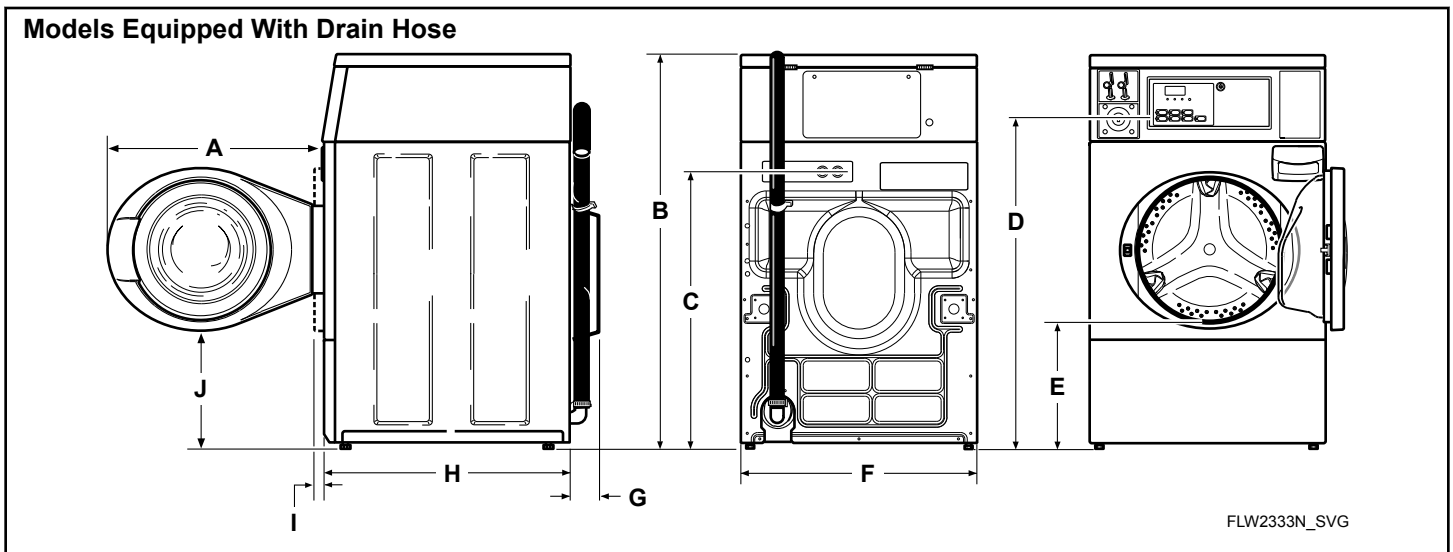

A	24 in. [610 mm]
B	44.34 in. [1126 mm]
C	32 in. [813 mm]
D	36.94 in. [938 mm]
E *	14.6 in. [371 mm]
F	26.875 in. [683 mm]
G	2.04 in. [52 mm]
H	27.73 in. [704 mm]
I (with door closed)	1.59 in. [40 mm]
J	13.1 in. [333 mm]

* For ADA compliance turn legs out from base 0.5 inches.

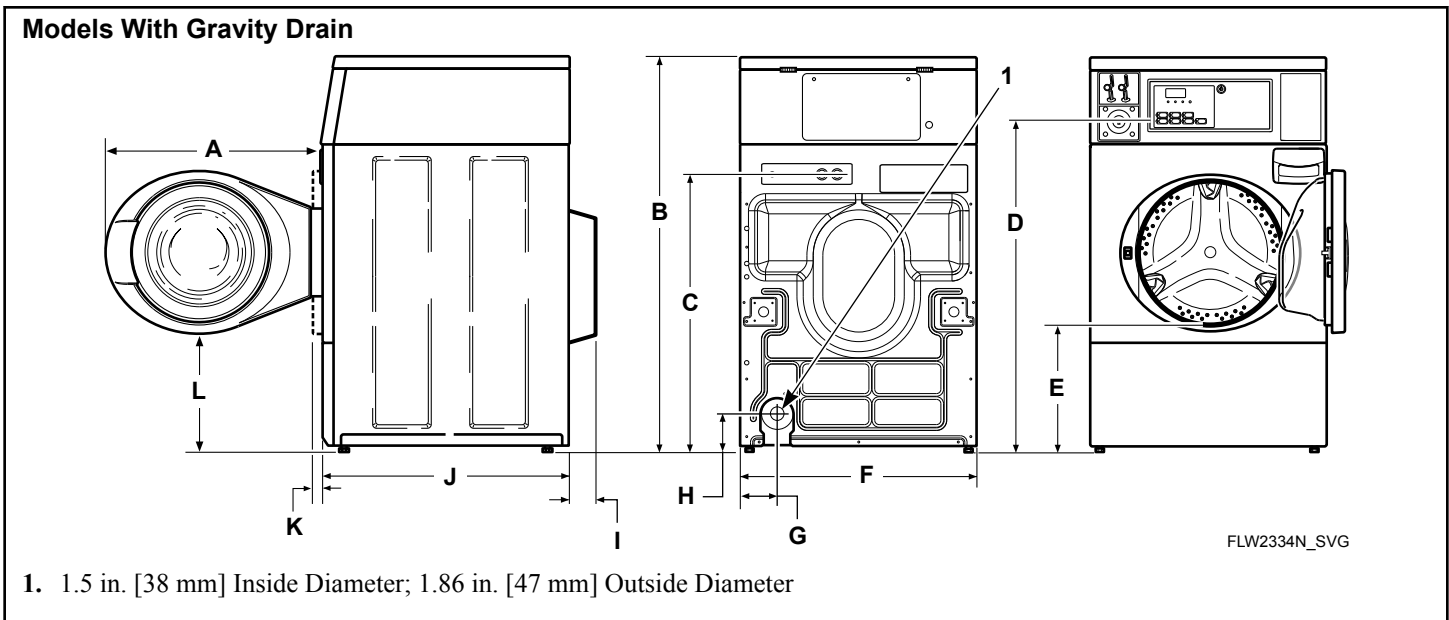

A	24 in. [610 mm]
B	44.34 in. [1126 mm]
C	32 in. [813 mm]
D	36.94 in. [938 mm]
E *	14.6 in. [371 mm]
F	26.875 in. [683 mm]
G	4.2 in. [107 mm]
H	4.1 in. [104 mm]
I	2.04 in. [52 mm]
J	27.73 in. [704 mm]
K (with door closed)	1.59 in. [40 mm]
L	13.1 in. [333 mm]

* For ADA compliance turn legs out from base 0.5 inches.

Installation

Before You Start

Tools

For most installations, the basic tools you will need are:

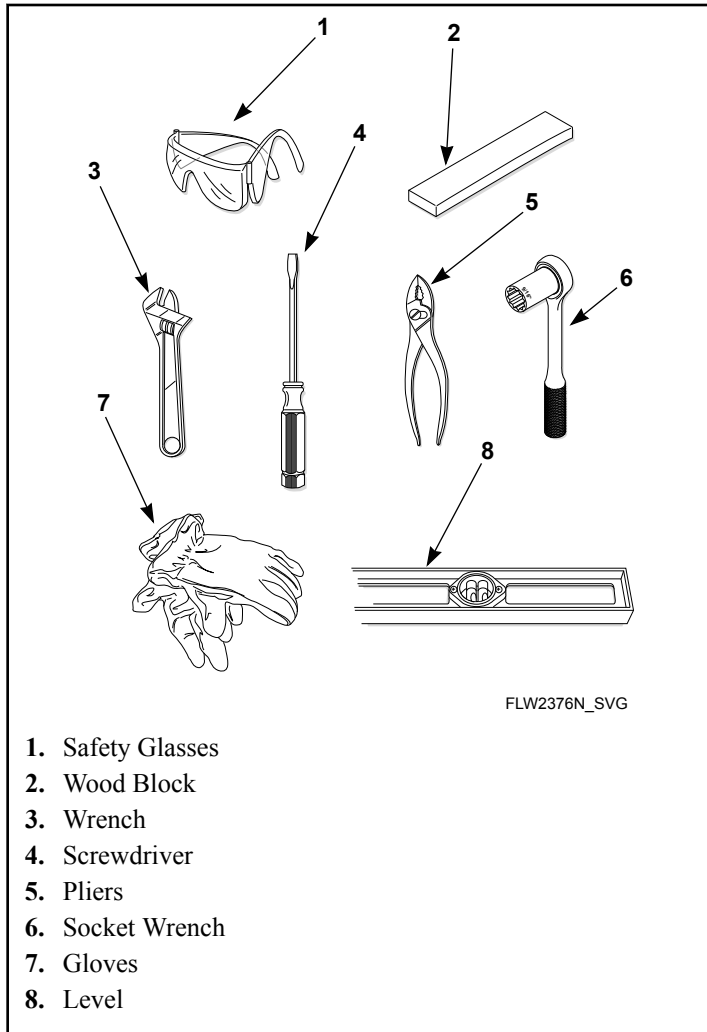

Figure 1

NOTE: An 8 in. [20.32 cm] coin drawer is required for coin operated models.

NOTE: If the washer is delivered on a cold day (below freezing), or is stored in an unheated room or area during the cold months, do not attempt to operate it until the washer has had a chance to warm up.

NOTE: Install dryer before washer. This allows room for attaching exhaust duct.

NOTE: Some moisture in the wash drum is normal. Water is used during testing at the manufacturer.

NOTE: This appliance is suitable for use in countries having a warm, damp climate.

Order of Installation Steps

The proper order of steps must be followed to ensure correct installation. Refer to the list below when installing your unit.

1. Position washer near the installation area.
2. Remove the shipping materials.
3. Connect the fill hoses.
4. For non-gravity drain models, connect the drain hose to the drain receptacle.
5. For gravity drain models, connect the drain outlet to the drain system.
6. Position and level the washer.
7. Wipe out inside of the washer.
8. Plug in the washer.
9. Check installation.

Position Unit Near Installation Area

Move unit so that it is within 4 feet [1.2 meters] of the desired area of installation.

NOTE: For best performance and to minimize vibration or movement, install washer on a solid, sturdy and level floor. Some floors may need to be reinforced, especially on a second floor or over a basement. Do not install the washer on carpeting, soft tile or other weakly supported structures.

Remove Shipping Materials

1. Remove two screws at bottom of front access panel. Rotate bottom of panel out and remove panel.

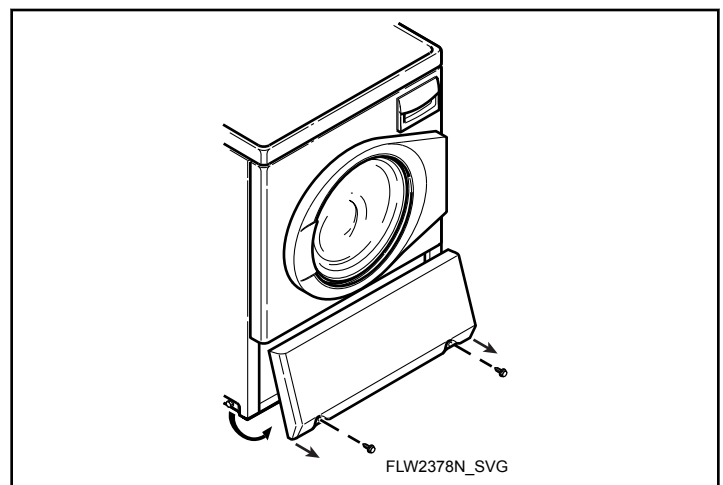

Figure 2

- Remove two 9/16 inch bolts and washers holding shipping brace to weight.
- Remove two 9/16 inch bolts and washers holding shipping brace to washer base and remove brace.

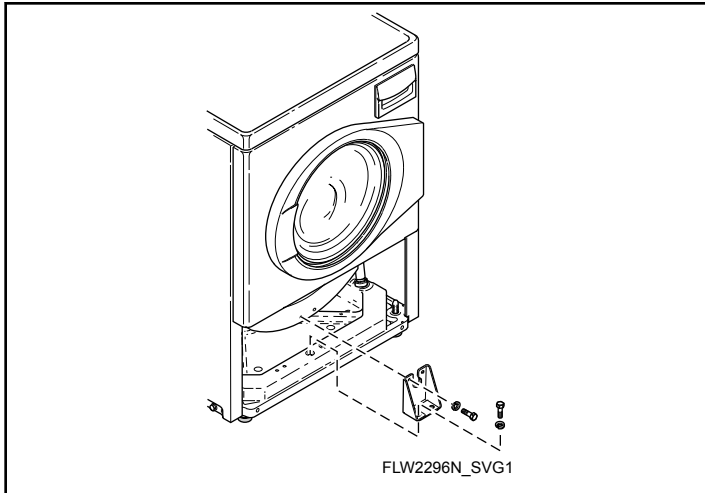

Figure 3

- Go to rear of washer and pull label from rear shipping bolts.
- Remove two 9/16 inch bolts. Unscrew each bolt while applying forward pressure just until bolt stops unthreading. Work each bolt and spacer out by hand using a circular motion.

NOTE: Avoid backing bolts out completely or spacers might fall into cabinet.

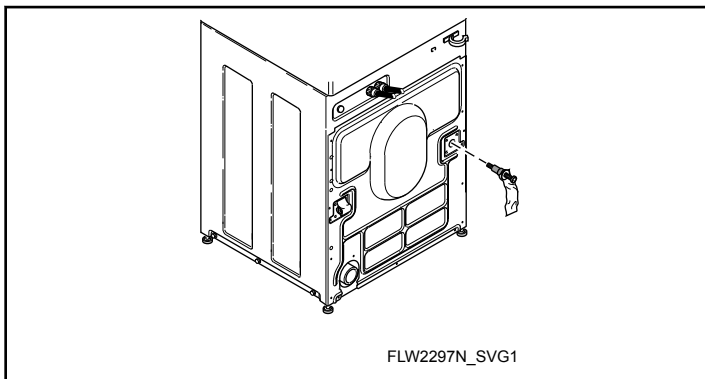

Figure 4

- Insert two plugs included in accessories bag into rear shipping bolt holes.

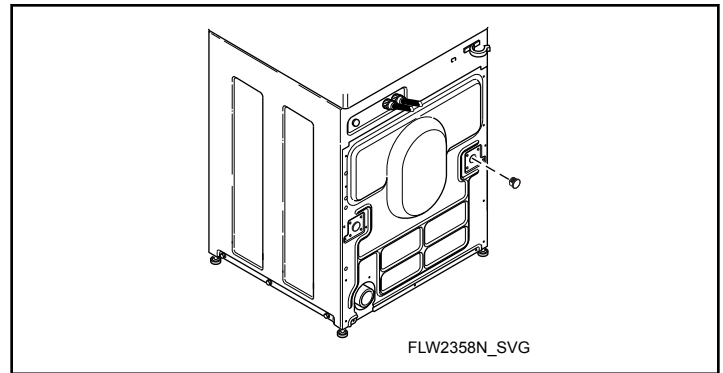

Figure 5

- Replace front access panel.
- Save all shipping materials. They must be reinstalled any time washer is moved more than four feet.

IMPORTANT: Do not lift or transport unit from front or without shipping materials installed. Refer to the Maintenance section for proper instructions on reinstalling the shipping materials.

Connect Fill Hoses



WARNING

Under certain conditions, hydrogen gas may be produced in a hot water system that has not been used for two weeks or more. **HYDROGEN GAS IS EXPLOSIVE.** If the hot water system has not been used for such a period and before using the washer, turn on all hot water faucets and let the water flow from each for several minutes. This will release any accumulated hydrogen gas. The gas is flammable. Do not smoke or use an open flame during this time.

W029

Water Supply Requirements

Water supply faucets must fit standard 3/4 inch [19 mm] female garden hose couplings. **DO NOT USE SLIP-ON OR CLAMP-ON CONNECTIONS.**

NOTE: Water supply faucets should be readily accessible to permit turning them off when washer is not being used.

Recommended cold water temperature is 50° to 75° Fahrenheit [10° to 24° Celsius]. Recommended maximum hot water temperature is 125° Fahrenheit [51° Celsius]. Warm water is a mixture of hot and cold water. Warm water temperature is dependent upon the water temperature and the pressure of both the hot and cold water supply lines.

	<h2 style="margin: 0;">WARNING</h2>
<p>To prevent personal injury, avoid contact with inlet water temperatures higher than 125° Fahrenheit [51° Celsius] and hot surfaces.</p>	
<p>W748</p>	

Maximum flow rate for all water temperatures is 2.5 gallons per minute [9.46 liters per minute] ± 15%.

Water pressure must be a minimum of 20 to a maximum of 120 pounds per square inch [minimum of 138 to a maximum of 827 kPa] static pressure measured at the faucet.

NOTE: Water pressure under 20 pounds per square inch [138 kPa] will cause an extended fill time in the washer and may not properly flush out the detergent dispenser.

Turn on the water supply faucets and flush the lines for approximately two minutes to remove any foreign materials that could clog the screens in the water mixing valve. This is especially important when installing your washer in a newly constructed or renovated building. Build-up may have occurred during construction.

Connecting Hoses

1. Insert rubber washers and filter screens (from accessories bag) in water fill hose couplings (two hoses supplied with washer). The filter screen must be facing outward.
2. Connect fill hose couplings with filter screens to water supply faucets.
3. Connect the other hose couplings to the hot and cold valve connections at the rear of the washer.
4. Thread hose couplings onto valve connections finger tight. Then turn 1/4 turn with pliers.

IMPORTANT: DO NOT cross thread or overtighten couplings. This will cause them to leak.

5. Turn water on and check for leaks.
6. If leaks are found, retighten the hose couplings.
7. Continue tightening and rechecking until no leaks are found.

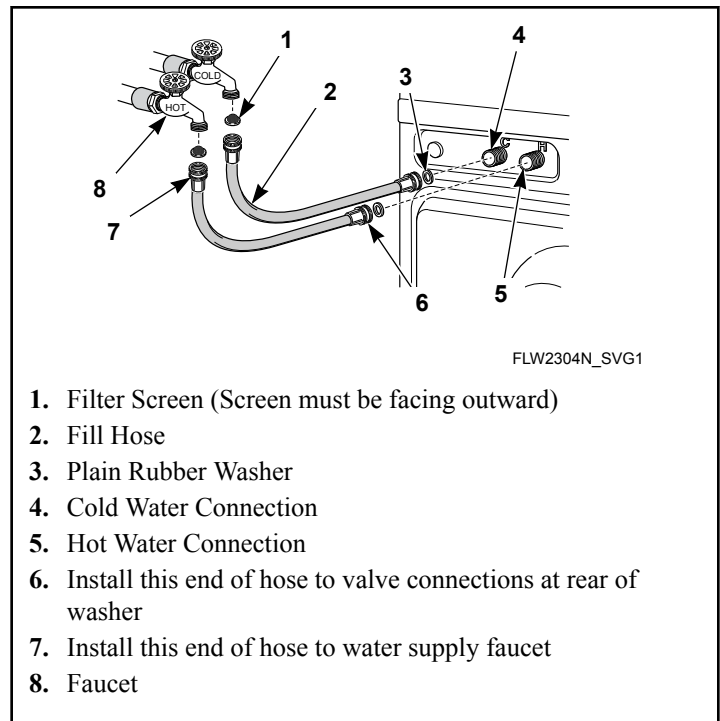

Figure 6

IMPORTANT:

Hoses and other rubber parts deteriorate after extended use. Hoses may develop cracks, blisters or material wear from the temperature and constant high pressure they are subjected to.

All hoses should be checked on a monthly basis for any visible signs of deterioration. Any hose showing the signs of deterioration listed above should be replaced immediately. All hoses should be replaced every five years.

IMPORTANT: Turn off water supply faucets after check-out and demonstration. Owner should turn off water supply whenever there will be an extended period of non-use.

NOTE: Longer fill hoses are available (as optional equipment at extra cost) if the hoses (supplied with the washer) are not long enough for the installation. Order hoses as follows:

- No. 20617 Fill Hose: 8 feet [2.44 m]
- No. 20618 Fill Hose: 10 feet [3.05 m]

Risers

Risers (or air cushions) may have to be installed if the pipes knock or pound when flow of water stops. The risers are more efficient when installed as close as possible to the water supply faucets. Refer to *Figure 7*.

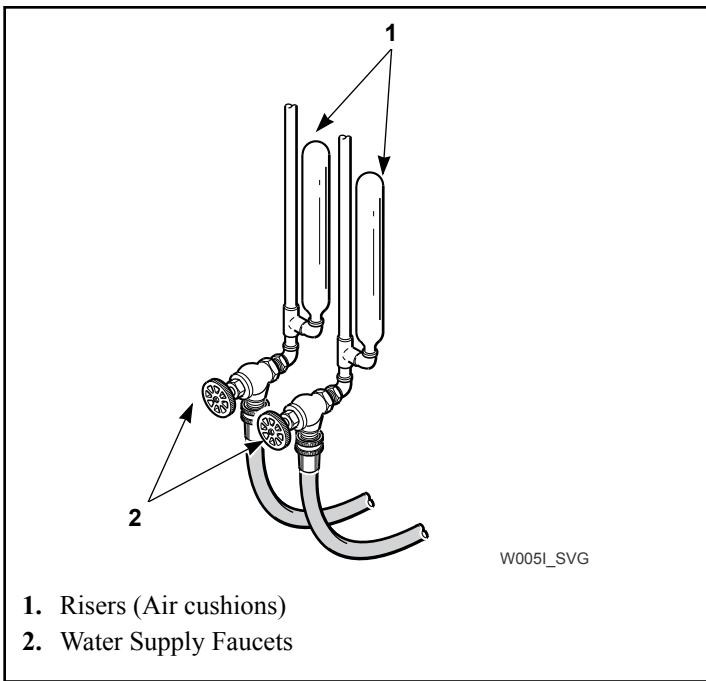

Figure 7

Drain Hose Models - Connect Drain Hose to Drain Receptacle

Remove the drain hose from its shipping position on the rear of the washer by removing the shipping tape.

IMPORTANT: Drain receptacle must be capable of handling a minimum of 1-3/8 inch [35 mm] outside diameter drain hose.

Drain Flow Rate	
Drain Height	Flow Rate gallons per minute [liters per minute]
3 ft. [0.9 m]	8.6 [32.7]
5 ft. [1.5 m]	6.8 [25.9]
6 ft. [1.8 m]	6.0 [22.7]
7 ft. [2.1 m]	5.1 [19.5]
8 ft. [2.4 m]	4.0 [15.2]

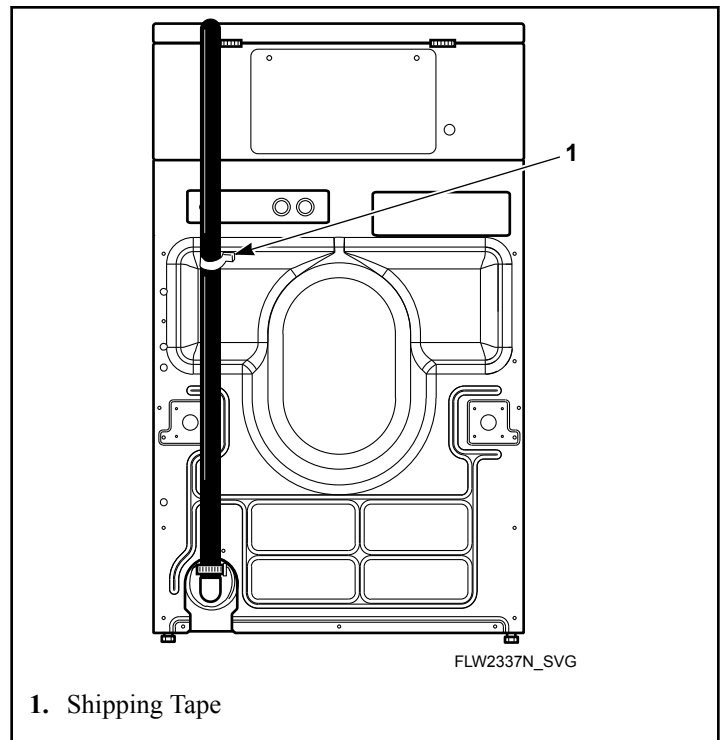
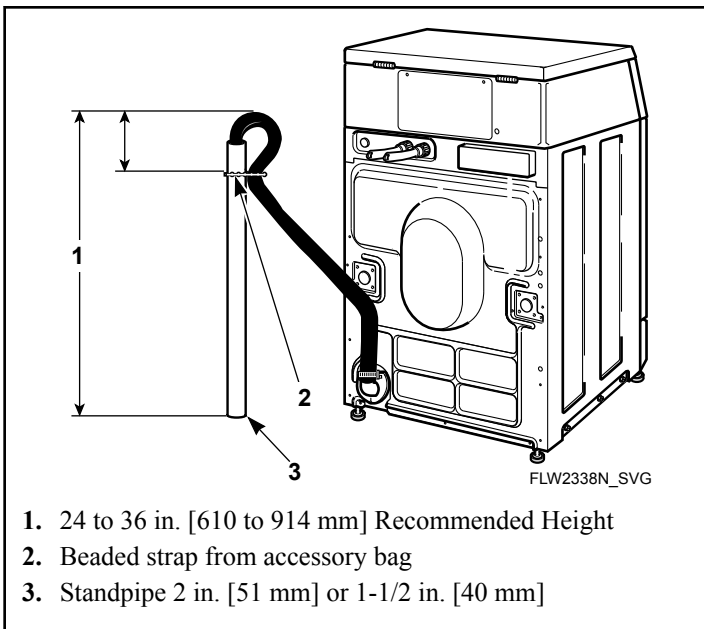

Figure 8

Standpipe Installation

1. Place the drain hose into the standpipe.
2. Remove the beaded tie-down strap from accessories bag and place around standpipe and drain hose and tighten strap to hold hose to standpipe. Refer to *Figure 9*. This will prevent the drain hose from dislodging from drain receptacle during use.
3. If hose does not fit securely in standpipe because it is too long:
 - a. Remove hose clamp attaching it to washer.
 - b. Cut hose to desired length.
 - c. Reattach hose and hose clamp.



1. 24 to 36 in. [610 to 914 mm] Recommended Height
2. Beaded strap from accessory bag
3. Standpipe 2 in. [51 mm] or 1-1/2 in. [40 mm]

Figure 9

Gravity Drain Models - Connect Drain Outlet to Drain System

Maximum flow rate is 24 gallons/minute [90.8 liters/minute]. Flow rates will vary with load type.

1. Remove drain fitting (4 inches [102 mm] long) and hose clamp from accessories bag. Insert drain fitting into drain outlet hose. Clamp hose and fitting.
2. Connect the drain fitting to a vented drain system using a flexible connection (obtain locally). Inside diameter of fitting is 1.53 in. [39 mm] and outside diameter is 1.66 in. [42 mm].
3. The drain system must be vented to prevent an air lock or siphoning.

IMPORTANT: Increasing the drain hose length, installing elbows, or causing bends will decrease drain flow rates and increase drain times, impairing machine performance.

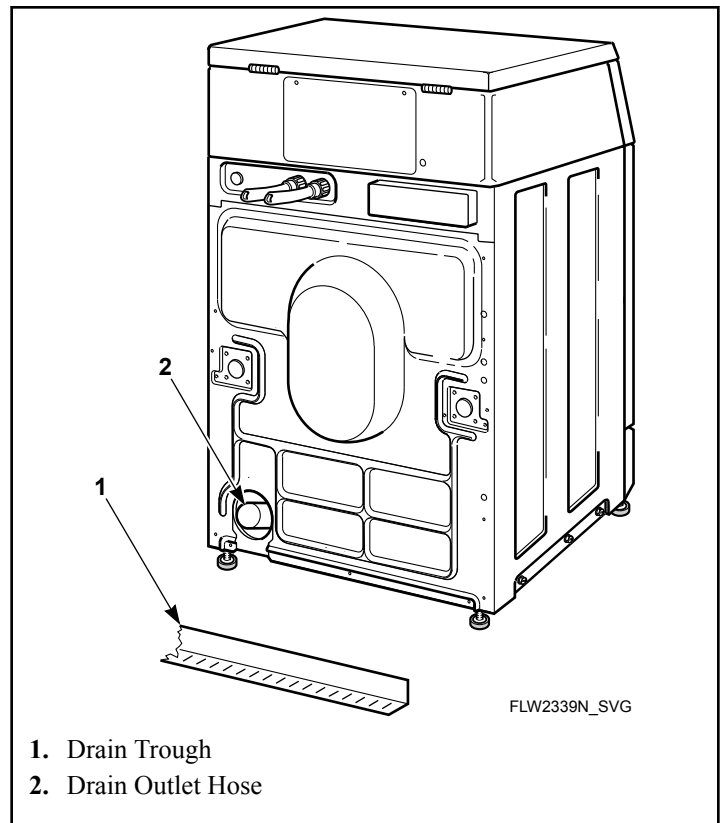

1. Drain Trough
2. Drain Outlet Hose

Figure 10

Position and Level the Washer



WARNING

Washers elevated above floor level must be anchored to that elevated surface, base or platform. The material used to elevate the washer should also be anchored to the floor to ensure that the washer will not walk or that the washer can not be physically pulled, tipped or slid from its installed position. Failure to do so may result in conditions which can produce serious injury, death and/or property damage.

W306

1. Position unit so it has sufficient clearance for installation and servicing.

NOTE: Use of the dispenser drawer or washer door as a handle in the transportation of the washer may cause damage to the dispenser or door.
2. Place unit in position on a solid, sturdy and level floor. Installing the unit on any type of carpeting, soft tile or other weakly supported structures is not recommended.
3. Place a level on the raised portion of cabinet top and check if the unit is level from side to side and front to back.

4. If unit is not level, tilt unit to access the front and rear leveling legs. For easier access to leveling legs, prop up unit with a wooden block.
5. Loosen 7/8 in. locknut and adjust legs by screwing into or out of unit base until the unit is level from side to side and front to back (using a level). Unit should not rock.

NOTE: Leveling legs can also be adjusted from inside the unit using an adjustable wrench.

6. Tighten the locknuts securely against the unit base. If the locknuts are not tight, unit will move out of position during operation.

NOTE: DO NOT slide unit across floor if the leveling legs have been extended. Legs and base could become damaged.

7. Remove rubber feet from accessories bag and place on all four leveling legs.
8. Verify that unit doesn't rock.

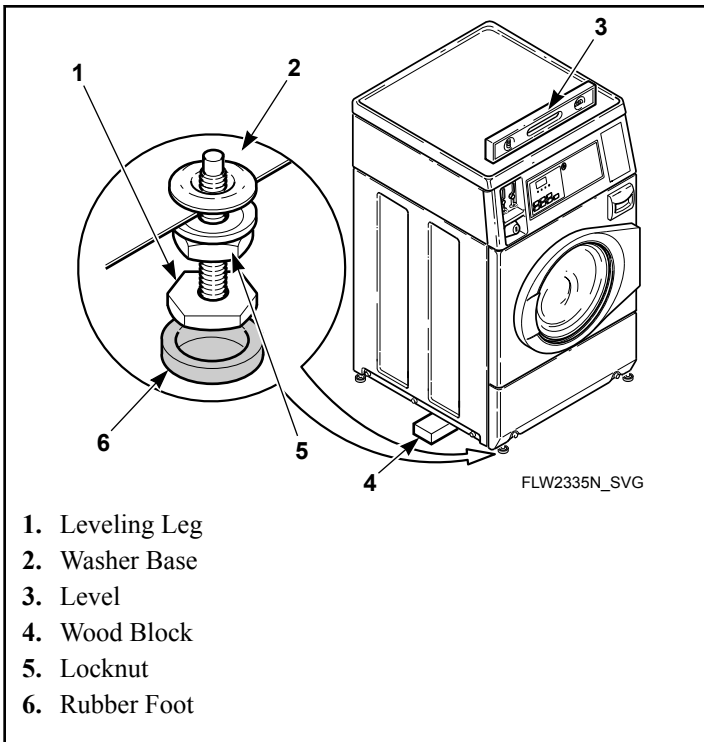

Figure 11

Wipe Out Inside of Wash Drum

Prior to first wash, use an all purpose cleaner or a detergent and water solution and a damp cloth to remove shipping dust from inside of the washer.

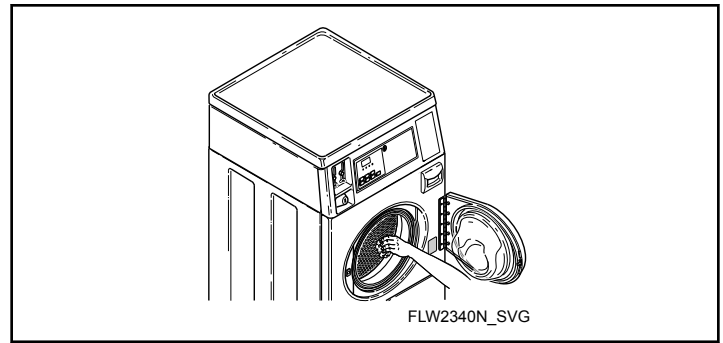

Figure 12

Supply Injection Models Only - Connect External Supplies to Washer

IMPORTANT: Undiluted chemical dripping can damage the washer.

1. Remove two nozzles from accessories bag. Use either the 3/8 inch or 1/4 inch nozzles, depending on the diameter of the dispenser tubing used.
2. Attach nozzles to rear of machine. Connection point located on cabinet, above water mixing valve. Refer to *Figure 13*.
3. Connect supply hoses to nozzles and secure with hose clamps (obtain locally). Refer to *Figure 13*.

NOTE: Hoses can be connected to either nozzle.

4. Refer to supply injection system instructions and label inside washer junction box cover (*Figure 14*) for electrical connection.
5. Do not attempt to make supply injection electrical connections to points other than those provided specifically for that purpose by the factory.
6. Refer to supply injection system instructions for details on operation.

Supply Injection System	
Number of liquid supply connections (1-Detergent and 2-Softener)	2
Liquid supply connection size, in. [mm]	3/8 [9.52] or 1/4 [6.35]

Table 1

WARNING

Wear eye and hand protection when handling chemicals; always avoid direct contact with raw chemicals. Read the manufacturer's directions for accidental contact before handling chemicals. Ensure an eye-rinse facility and an emergency shower are within easy reach. Check at regular intervals for chemical leaks.

SW016

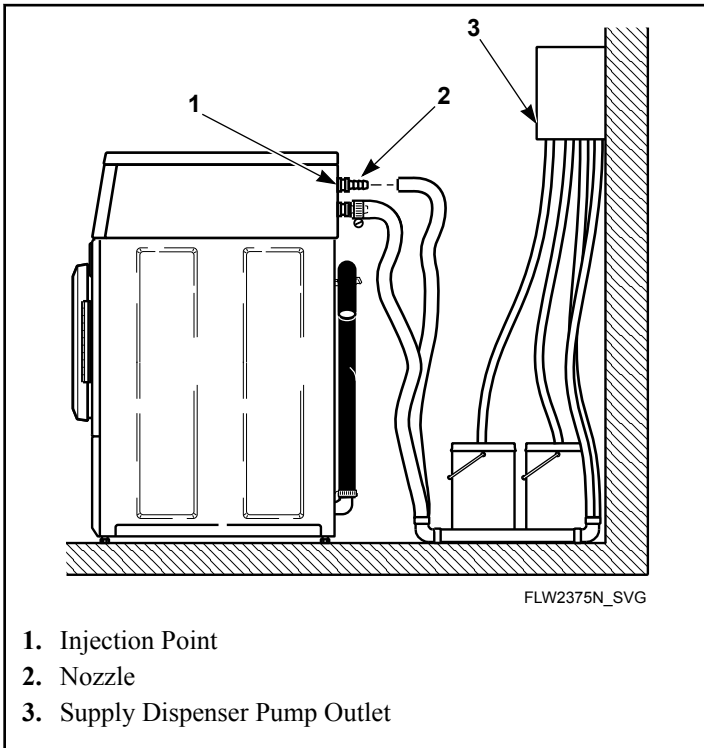

Figure 13

A junction box on the rear panel houses a terminal strip which furnishes supply output signals for the supply injection pumps. These are dry contacts. Voltage needs to be supplied. Refer to the chemical injection electrical interface label.

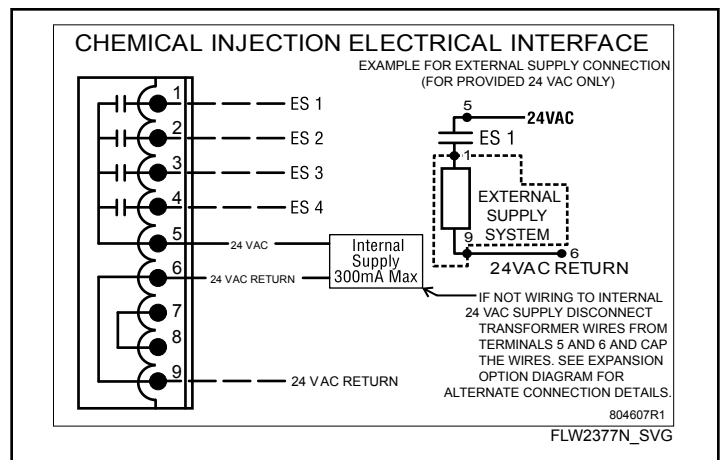

Figure 14

These terminals may be used to provide signals to the supply injection system but must not be used to provide power to the actual pump.

Any injection system pump which requires 110 VAC must be powered by a separate external power source.

Control Function Test

The washer should be cleaned after the installation is complete. A function test should then be executed on the unloaded machine:

1. Check the power supply for such characteristics as correct voltage, phase, and cycles to be certain they are correct for the washer.
2. Open manual shut-off valves to the washer.
3. Apply power to the washer.

Plug In the Washer

Electrical Requirements

120 Volt, 60 Hertz with 3-Prong Earth/Ground Plug

NOTE: The wiring diagram is located in the control cabinet.

WARNING

To reduce the risk of fire, electric shock, serious injury or death, all wiring and protective earth/ground connections MUST conform with the latest edition of the National Electrical Code, ANSI/NFPA No. 70, and such local regulations as might apply. It is the customer's responsibility to have the wiring, fuses and circuit breakers installed by a qualified electrician to make sure adequate electrical power is available to the washer.

W824

When plugging in the washer:

- DO NOT overload circuits.
- DO NOT use an extension cord.
- DO NOT use an adapter.
- DO NOT operate other appliances on the same circuit. Use separately fused 15 Amp circuits.

The washer is designed to be operated on a separate branch, polarized, three-wire, effective earth/ground, 120 Volt, 60 Hertz, AC (alternating current), circuit protected by a 15 ampere fuse, equivalent fusetron or circuit breaker.

The three-prong earth/ground plug on the power cord should be plugged directly into a polarized three-slot effective earth/ground receptacle rated 110/120 Volts AC (alternating current) 15 Amps. Refer to *Figure 15* to determine correct polarity of the wall receptacle.

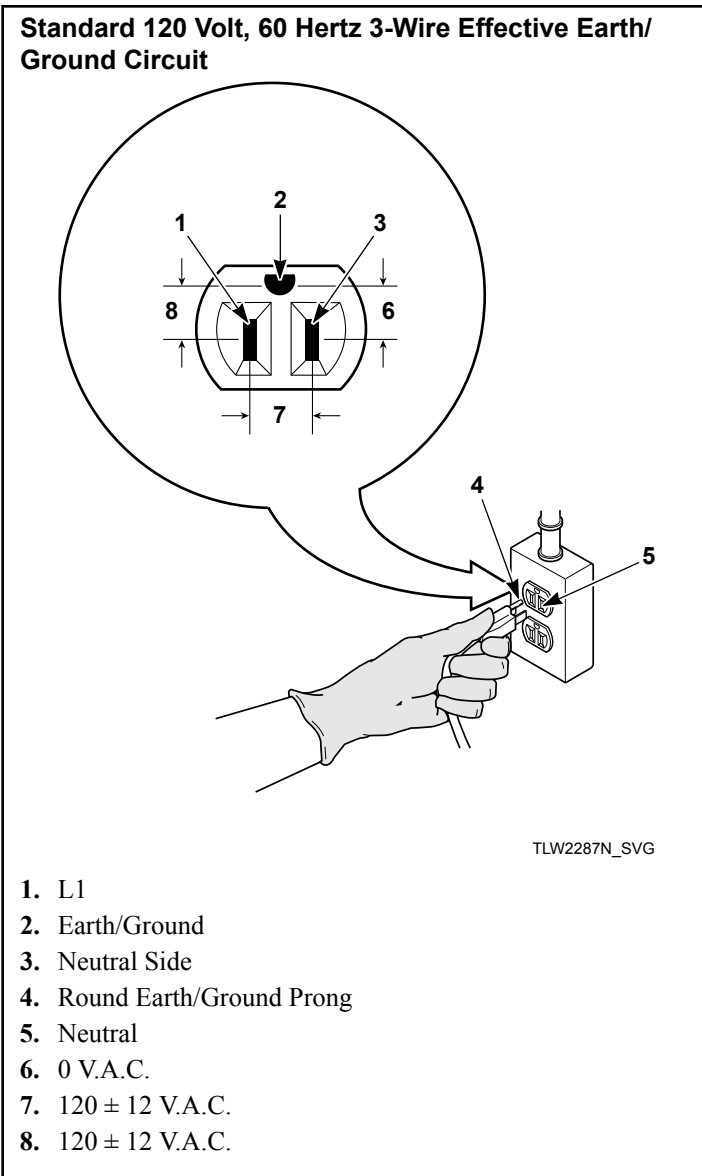

Figure 15

	WARNING
To reduce the risk of an electric shock or fire, DO NOT use an extension cord or an adapter to connect the washer to the electric power source.	
W082	

Earth/Ground Instructions

This appliance must be properly connected to protective earth/ground. In the event of malfunction or breakdown, the earth/ground will reduce the risk of electric shock by providing a path of least resistance for electric current.

The appliance is equipped with a cord having an equipment earth/ground conductor and a three-prong earth/ground plug. The plug must be plugged into an appropriate outlet that is properly installed and connected to a protective earth/ground in accordance with all local codes and ordinances.

	WARNING
Improper connection of the equipment earth/ground conductor can result in a risk of electric shock. Check with a qualified electrician or service person if you are in doubt as to whether the unit is properly connected to a protective earth/ground.	
W893	

- DO NOT modify the plug provided with the unit – if it will not fit the outlet, have a proper outlet installed by a qualified electrician.
- If the laundry room’s electrical supply does not meet the above specifications and/or if you are not sure the laundry room has an effective earth/ground, have a qualified electrician or your local electrical utility company check it and correct any problems.

	WARNING
Any disassembly requiring the use of tools must be performed by a suitably qualified service person.	
W299	

	WARNING
This unit is equipped with a three-prong (earth/ground) plug for your protection against shock hazard and should be plugged directly into a protective earth/ground three-prong receptacle. Do not cut or remove the earth/ground prong from this plug.	
W823	

Check Installation

1. Refer to Installer Checklist on the back cover of this manual and make sure that unit is installed correctly.
2. Run washer with a test load to make sure it is operating properly and properly leveled.
 - a. Put about six pounds of laundry (four bath towels and three jeans) into washer.
 - b. Close door.
 - c. Rapid advance to the final spin part of the cycle.
 - d. When washer spins at high speed, verify that it is stable.
 - e. If it is not, after cycle is complete, refer to Position and Level the Washer to readjust leveling legs.

Operation

Operation Instructions

IMPORTANT: Prior to first wash, use an all-purpose cleaner, or a detergent and water solution, and a damp cloth to remove shipping dust from inside of washer.

IMPORTANT: Remove all sharp objects from laundry to avoid tears and rips to items during normal machine operation.

Load Laundry

1. Load items loosely into wash drum. (21 pounds [9.5 kg] maximum dry clothes load)

NOTE: Small items such as baby socks may get caught around the door. Place these articles inside a mesh garment bag.

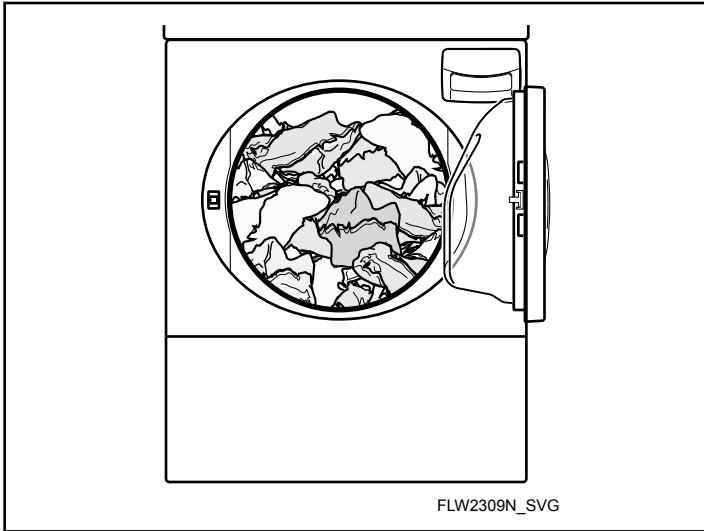

Figure 16

2. When washing bulky items such as blankets and comforters, use the DELICATES/BULKY cycle. The cycle includes agitation and final spin speeds that maintain the load's balance and minimize wear to the articles.

NOTE: Different fabrics will have different densities and loads must be adjusted accordingly to meet machine loading specifications shown.

Close Loading Door

Close loading door tightly. The washer will not operate with the loading door open.

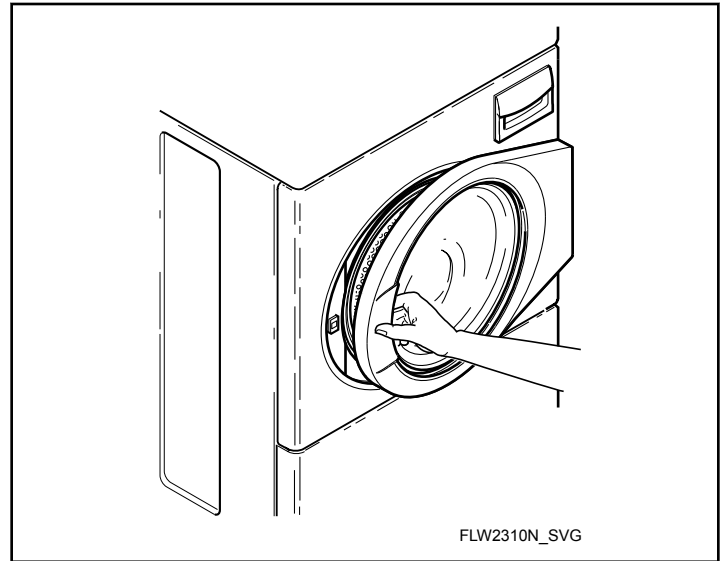

Figure 17

Add Laundry Supplies

1. Open dispenser drawer.
2. Measure and add low sudsing, high efficiency (HE) main wash detergent (1), bleach (2), fabric softener (3) and pre-wash detergent (4) to the dispenser drawer.

IMPORTANT: If using single-load laundry detergent packets or 3-in-1 laundry sheets, **DO NOT** place them in the dispenser drawer. Place them directly in the wash drum with clothes.

IMPORTANT: If using non-HE detergent, avoid over-sudsing by using 1/2 of the detergent manufacturer's recommended amount.

3. Close dispenser drawer.

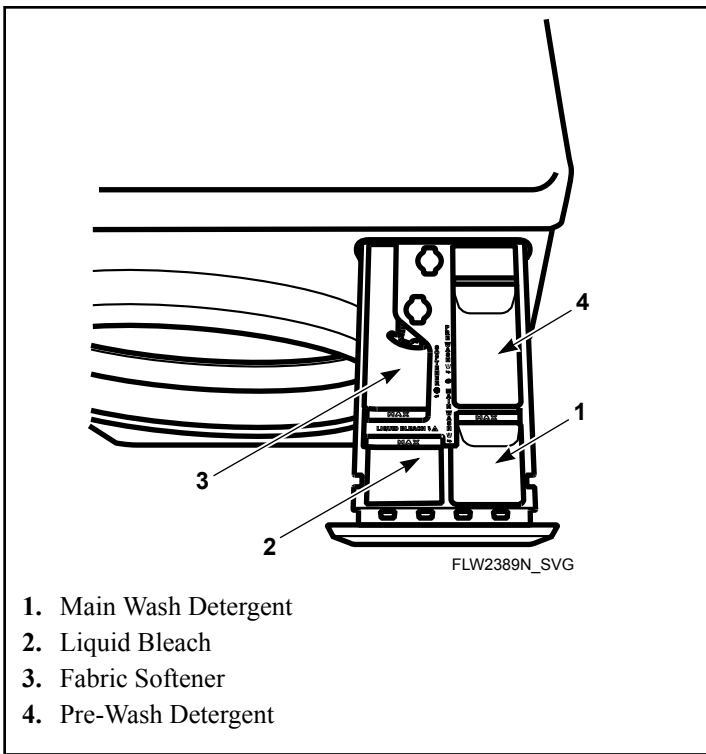

1. Main Wash Detergent
2. Liquid Bleach
3. Fabric Softener
4. Pre-Wash Detergent

Figure 18

Set Cycle

1. Push touchpad for NORMAL, PERM PRESS or DELICATES/BULKY cycle.
2. Light indicates selection.

NOTE: Changes can be made to Fabric Selector setting up until the first fill is complete.

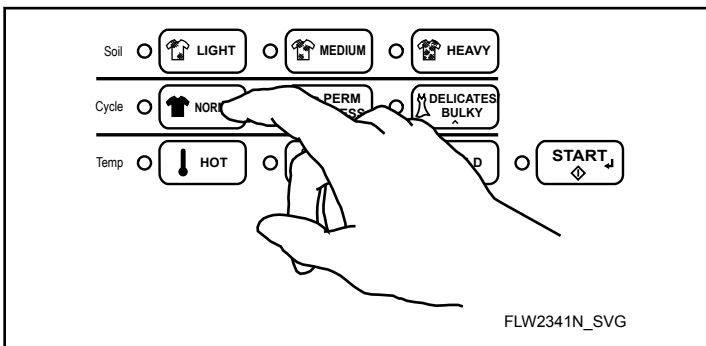

Figure 19

Set Wash Temperature

1. Push touchpad for HOT, WARM or COLD.
2. Light indicates selection.

NOTE: Always follow manufacturer's care labels.

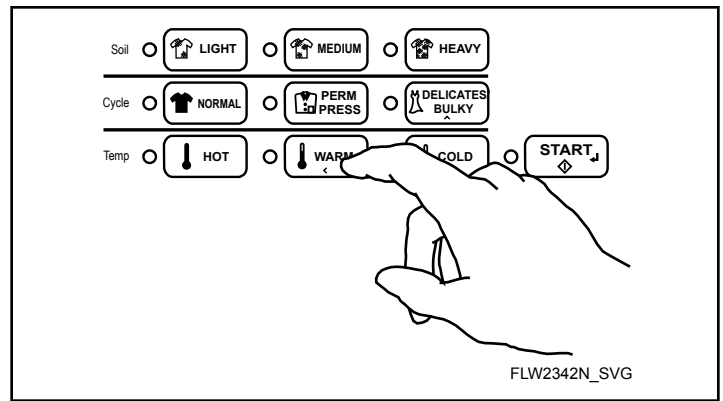

Figure 20

Set Soil Level

1. Push Soil Level touchpad to select LIGHT, MEDIUM or HEAVY.
2. LED light indicates selection.

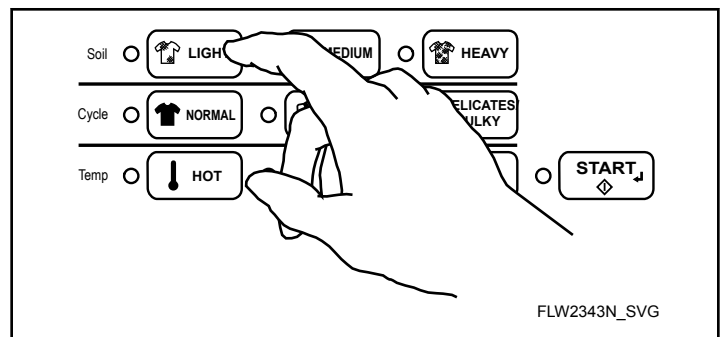

Figure 21

Insert Coins or Card

To Insert Coins

1. Insert coin(s) in coin slot.
2. Check pricing as seen on digital display.

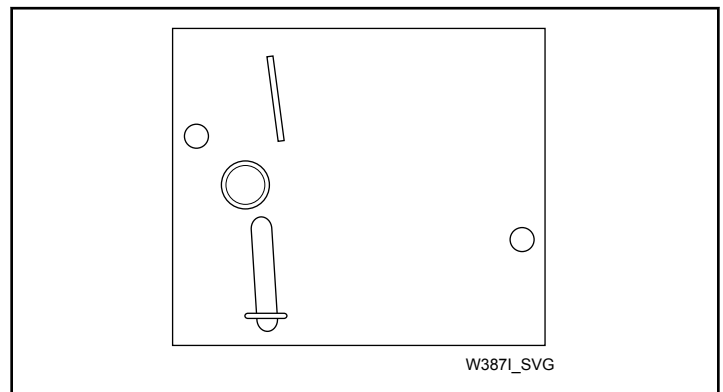

Figure 22

To Insert Card

Insert card into opening.

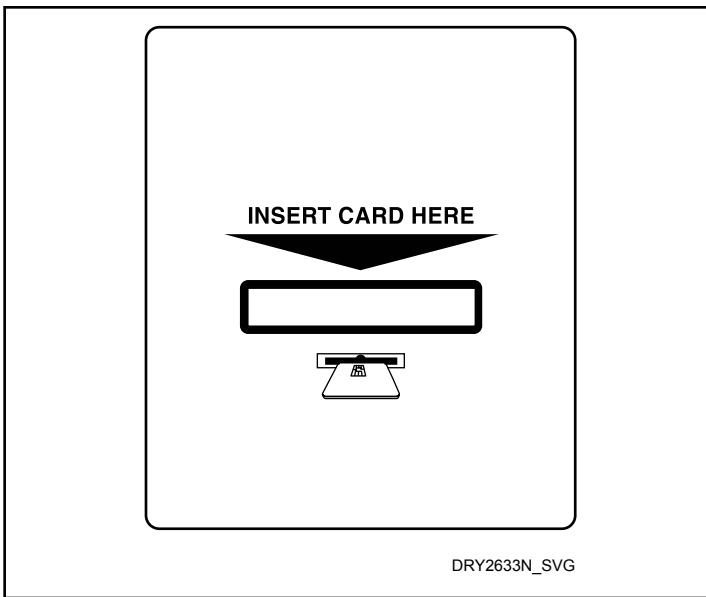

Figure 23

Start Washer

1. After vend price has been satisfied, push the START pad.
2. Door must be closed to start washer.

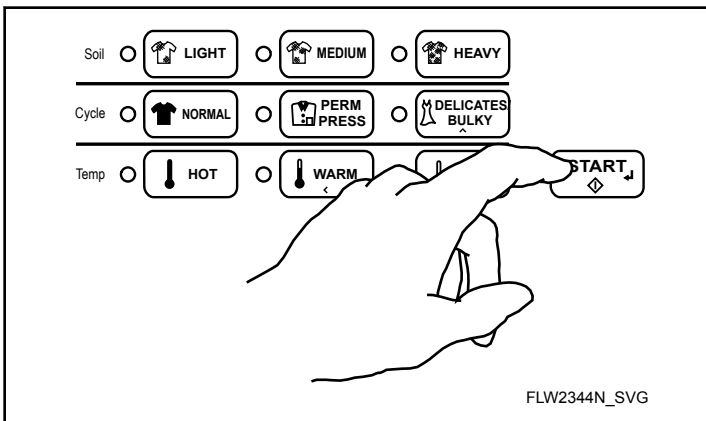

Figure 24

Indicator Lights

INSERT COINS/CARD	INSERT COINS/CARD is lit to prompt the user to insert payment to satisfy the vend price. When INSERT COINS/CARD is lit, the digits show the vend price remaining to be satisfied.
WASH	WASH is lit during the WASH portions of the cycle.
RINSE	RINSE is lit during the RINSE portions of the cycle.

Table continues...

SPIN	SPIN is lit during the final spin portion of the cycle.
DOOR	DOOR is lit whenever the door is locked. The door cannot be opened when this light is on.
START	START flashes one second on and one second off when the full vend price has been satisfied.

IMPORTANT: If washer fails to operate properly after installation, make sure electrical service and water supply faucets are turned on. Are all the controls properly set? Have a qualified service person refer to the wiring diagram (located inside of washer control cabinet) and check for broken, loose or incorrect wiring.

NOTE: Once a cycle has started, the door can only be opened by first unplugging the power cord and waiting one minute.

	WARNING
<p>To reduce the risk of bodily injury, do not remove laundry from washer until all lights are out, and all moving parts have stopped.</p>	
W092	

Maintenance

User-Maintenance Instructions

Lubrication

All moving parts are sealed in a permanent supply of lubricant or are equipped with oilless bearings. Additional lubrication will not be necessary.

Do not lubricate the door hinge. If the hinge makes noise, replace the hinge.

Cold Weather Care

If the unit is delivered on a cold day (below freezing), or is stored in an unheated room or area during the cold months, do not attempt to operate the washer until it has had a chance to warm up. Water from the previous cycle may remain.

Care of Your Washer

Use only a damp or sudsy cloth for cleaning the control panel. Some cleaning products may harm the finish on the control panel or damage the interior. **DO NOT** use products that contain alcohol on the control panel. Wipe the panel dry after cleaning.

Wipe the washer cabinet as needed. If detergent, bleach or other washing products are spilled on the cabinet, wipe immediately. Some products will cause permanent damage if spilled on the cabinet.

Do not use scouring pads or abrasive cleansers on control panel or cabinet.

The wash drum will need no particular care although it may need rinsing or wiping after an unusual load has been washed.

The outside of the door window can be cleaned with household window cleaner.

Leave the door and dispenser drawer open slightly when not in use. This will help keep them dry and prevent musty smells.

Running an occasional rinse cycle with bleach will help to avoid a musty smell in the wash drum.

Cleaning Glass Sealing Area

In order to assure that the door properly seals against water leaks, the following surfaces should be wiped off periodically:

- The outside perimeter of the door glass where the seal contacts the glass
- The front surface of the door seal lip

Usually a mild soap solution will work. If there is an extreme build-up of minerals from a hard water supply, the surfaces may need to be cleaned with a lime removal chemical.

Replacing Hoses

Hoses and other rubber parts deteriorate after extended use. Hoses may develop cracks, blisters or material wear from the temperature and constant high pressure they are subjected to.

All hoses should be checked on a monthly basis for any visible signs of deterioration. Any hose showing the signs of deterioration listed above should be replaced immediately. All hoses should be replaced every five years.

Filter Screens

Check the filter screens in the fill hoses for debris or damage every six months. Clean or replace them if necessary.

If the washer is filling with water slower than normal, check the filter screens. Clean or replace them if necessary.

Order filter screen Part No. 803615 from the nearest authorized parts distributor.

Extended Non-Use

IMPORTANT: To avoid possible property damage due to flooding, turn off the water supply to the washer whenever there will be an extended period of non-use.

Leave the loading door and dispenser drawer open during extended periods of non-use to allow the wash drum and drawer to dry out and avoid a musty smell.

Cleaning Foreign Object Trap

The washer's pump has a trap that may collect foreign objects. The trap may need to be cleaned if water is draining slower than usual. To clean:

1. Disconnect washer from electrical supply.
2. Remove two screws at bottom of the front access panel.
3. Rotate bottom of panel out and remove panel.

NOTE: The pump may have some water in it. Use a rag or a container to catch water. If the wash drum is full of water, use a wet/dry shop vacuum to catch the water.

4. With rag or vacuum ready, unscrew the cap on the left side of the pump and remove trap.
5. Clean the debris from the trap.
6. Reinstall the trap and access panel.
7. Reconnect washer to electrical supply.

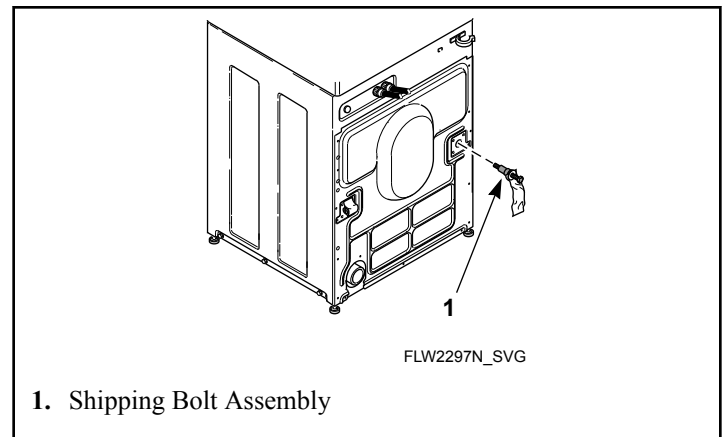
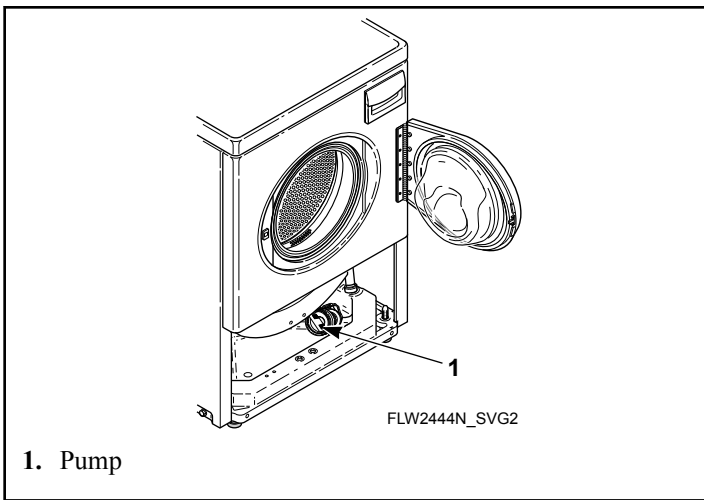

Figure 26

Reinstallation of Shipping Materials

To prevent damage while moving the unit, the shipping materials **MUST** be reinstalled.

1. Disconnect washer from electrical supply.
2. Remove two screws at bottom of front access panel.
3. Rotate bottom of panel out and remove panel.
4. Attach shipping brace to weight and base using four bolts and washers. Refer to *Figure 25*.
5. Reinstall front access panel.
6. Go to rear of washer to install rear shipping bolt, washer, spacer assemblies.
7. Insert shipping bolt assemblies into each shipping bolt hole. Refer to *Figure 26*.
8. Tighten bolt while pressing washer against rear panel to ensure spacer is fully inserted.

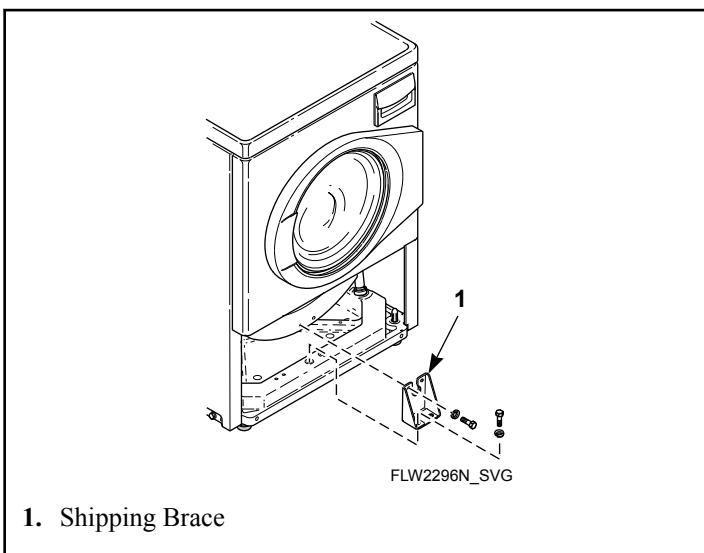

Figure 25

Troubleshooting

Try these troubleshooting tips before making a service call. They may save you time and money.

Washer Symptom	Possible Cause/Solution
Won't Fill	<ul style="list-style-type: none"> • Make sure power cord is plugged all the way into the electrical outlet. • Check the laundry room fuse or circuit breaker. • Make sure that the controls are properly set. • Press START keypad. • Make sure that the loading door is closed tightly. • Make sure hot and cold water faucets are turned on. • Make sure that the fill hoses are not kinked or twisted. • Clean the screens in the water mixing valve and the filter screens located at the faucet end of the fill hoses.
Won't Start	<ul style="list-style-type: none"> • Make sure power cord is plugged all the way into the electrical outlet. • Check the laundry room fuse or circuit breaker. • Make sure that the controls are properly set. • Press START keypad. • Make sure that the loading door is closed tightly. • Insert coin(s) or card. • Make sure door latch is properly adjusted relative to door lock.
Won't Spin/Tumble	<ul style="list-style-type: none"> • Make sure power cord is plugged all the way into the electrical outlet. • Check the laundry room fuse or circuit breaker. • Make sure that the controls are properly set. • Press START keypad. • Make sure that the loading door is closed tightly. • Broken drive belt. Call the service person. • Foreign object trap in pump may be clogged. Clean the trap. Refer to Maintenance section.
Stops/Pauses During Cycle	<ul style="list-style-type: none"> • Pauses are part of the washer's normal operation. • Check the laundry room fuse or circuit breaker. • Wash load may be unbalanced. Washer will stop and then restart spin automatically.
Won't Drain	<ul style="list-style-type: none"> • Make sure drain hose is not kinked or twisted. • Make sure drain hose is not clogged. • Make sure drain receptacle is not clogged. • Refer to the Installation instructions to make sure that the drain hose has been properly installed. • Foreign object trap in pump may be clogged. Clean the trap. Refer to Maintenance section.

Table continues...

Washer Symptom	Possible Cause/Solution
Water Leaks	<ul style="list-style-type: none"> • Check that fill hoses are properly installed on the faucets and the washer’s water mixing valve. • Check the condition of the fill hoses. Replace fill hoses every five years. • Make sure drain receptacle is not clogged. • Check laundry room plumbing. • Check the condition of the rubber door gasket for tears or holes. • Laundry load may be oversudsing. Make sure you are using low-sudsing, high efficiency (HE) detergent. • Laundry load may be overloaded. Make sure you are using proper load sizes. • Make sure outside perimeter of the door glass where seal contacts glass is clean.
Too Many Soap Suds	<ul style="list-style-type: none"> • Laundry load may be oversudsing. Make sure you are using low-sudsing, high efficiency (HE) detergent. • Make sure you are using the amount of detergent recommended on the detergent’s label. If using non-HE detergent, use only 1/2 of the detergent manufacturer's recommended amount. • Laundry load may be overloaded. Make sure you are using proper load sizes.
Vibrates/Moves Slightly	<ul style="list-style-type: none"> • Make sure washer is level. Uneven leveling can cause vibration. • Make sure washer is installed on a solid, sturdy and level floor. The washer should not be installed on carpeting, soft tile, a platform or other weakly supported structures. • Make sure rubber feet are installed on all four leveling legs. Refer to Position and Level the washer.
Is Noisy	<ul style="list-style-type: none"> • Make sure washer is level. Uneven leveling can cause vibration. • Some sounds may be a part of normal operation for a frontload washer, such as clicking noise when door locks and clicking noise from balance ring during agitate part of cycle.
Load is too Wet	<ul style="list-style-type: none"> • Wash load may be unbalanced. The washer may have limited the spin speed to prevent damage to the machine. Redistribute the load. • Load is too small. Add items to make full load.
Wrong Water Temperature	<ul style="list-style-type: none"> • Make sure that the controls are properly set. • Check fill hoses. Make sure hot faucet hose is connected to hot mixing valve (indicated with “H” on the valve bracket) and cold faucet is connected to cold mixing valve (indicated with “C” on the valve bracket). • Make sure laundry room water heater is adjusted properly.

Contact Information

If service is required, contact the nearest Factory Authorized Service Center.

If you are unable to locate an authorized service center or are unsatisfied with the service performed on your unit, contact:

Alliance Laundry Systems
Shepard Street
P.O. Box 990
Ripon, WI 54971-0990
U.S.A.
www.alliancelaundry.com
Phone: +1 (920) 748-3121

When calling or writing about your unit, PLEASE GIVE THE MODEL AND SERIAL NUMBERS. The model and serial numbers are located on the serial plate. The serial plate will be in the location shown in *Figure 27*.

Date Purchased	
----------------	--

Table continues...

Model Number	
Serial Number	

Please include a copy of your bill of sale and any service receipts you have.

	WARNING
<p>To reduce the risk of serious injury or death, DO NOT repair or replace any part of the unit or attempt any servicing unless specifically recommended in the user-maintenance instructions or in published user-repair instructions that you understand and have the skills to carry out.</p>	
W329	

If replacement parts are required, contact the source from where you purchased your unit or call +1 (920) 748-3950 for the name and address of the nearest authorized parts distributor.

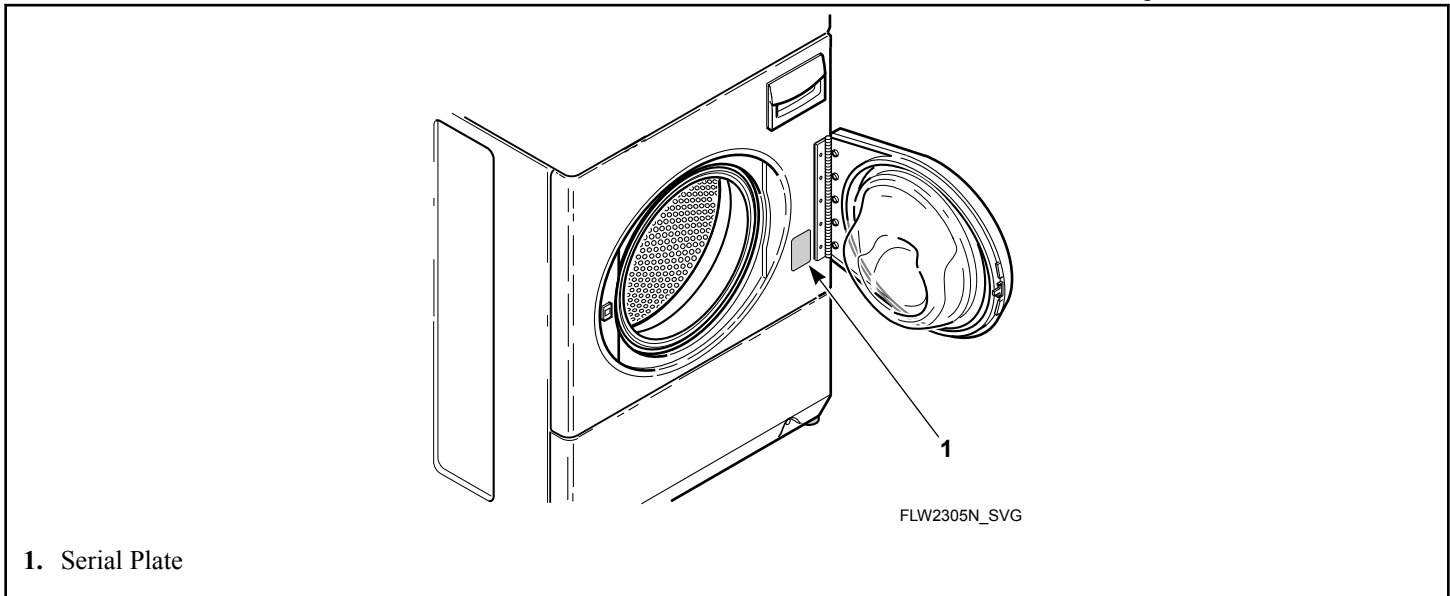
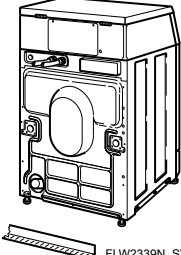
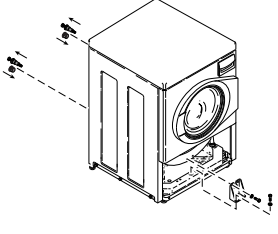
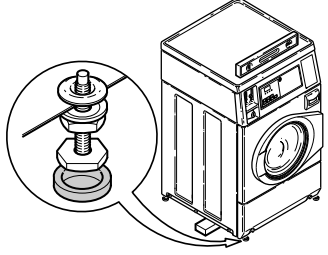
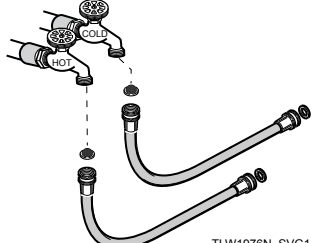
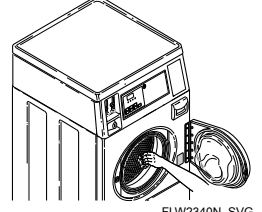
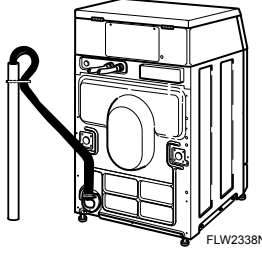
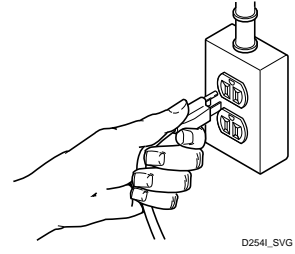

Figure 27

Installer Checklist

Fast Track for Installing the Washer

1	Position Washer Near Installation Area.	5	Gravity Drain Models - Connect Drain Outlet to Drain System.	
	CHECK		CHECK  FLW2339N_SVG1	
2	Remove the Shipping Materials and Install Plugs.	 FLW2359N_SVG	6	Position and Level the Washer.
	CHECK		CHECK	 FLW2335N_SVG1
3	Connect Fill Hoses.	 TLW1976N_SVG1	7	Wipe Out Inside of Washer.
	CHECK		CHECK	 FLW2340N_SVG
4	Non-Gravity Drain Models - Connect Drain Hose to Drain Receptacle.	 FLW2338N_SVG1	8	Plug In the Washer.
	CHECK		CHECK	 D254I_SVG

Refer to the manual for more detailed information