

Mechanical & Structural Engineering

Applications

- Bulk Materials Handling
- Ship Loading
- Stockpiling
- Various Materials



The HMA Jet Slinger range is designed & manufactured to the specific needs of our customers. It can increase capacity and flexibility within existing ship loading and stockpiling facilities at a low capital cost investment. Increased return on investment for operators of ship loading facilities and their customers alike is achievable with the HMA Jet Slinger through improved ship loading times and increased load volume.

Our standard range includes models from light transportable units, commonly used in container loading facilities, through to high volume & high speed models used for bulk materials handling, mine site stockpiling and the largest of bulk carrier ship loading facilities. The HMA Jet Slinger is at the forefront of advanced engineering. Quality design & reliability makes this a must have piece of equipment in today's bulk product handling facilities.

Chute Work and Liners

The HMA Jet Slinger chute is manufactured without internal ledges assisting to prevent material hang-up. Combining this feature with our expanding flow design provides additional insurance against chute blockage compared to traditional designs. HMA's Jet Slinger chute body is manufactured from corrosion resistant steel offering a superior level of product flow and wear resistance. Lining options including Thermo Plastics and Ceramics, can be applied for handling highly abrasive materials.

Trajectory Adjustment

HMA Jet Slingers are offered with variable or fixed trajectory (luff) angle adjustment. The trajectory can be varied manually, electrically or as an option using on-board mounted hydraulics.

Quick Belt Change Facility

The design has been optimised to reduce the belt change time. Skilled maintenance teams of 2 are able to change a belt in one hour without the use of heavy lifting equipment

Complete System Integration

The HMA Jet Slinger is compatible for use with our entire range of Materials Handling Equipment allowing for a complete product solution.

Items within this range include: Telescopic Chute systems complete with designed for purpose winch systems, Gimbals and Head Chutes.

Materials Handling Dust Control solutions, Spoon Chutes and Conveyor Plough installations, Fixed and Radial Product Stacking Conveyors, Skyline Conveyor Trippers and Tripping Conveyor systems, Dockside Ship Loading and Portside Materials Handling Equipment.

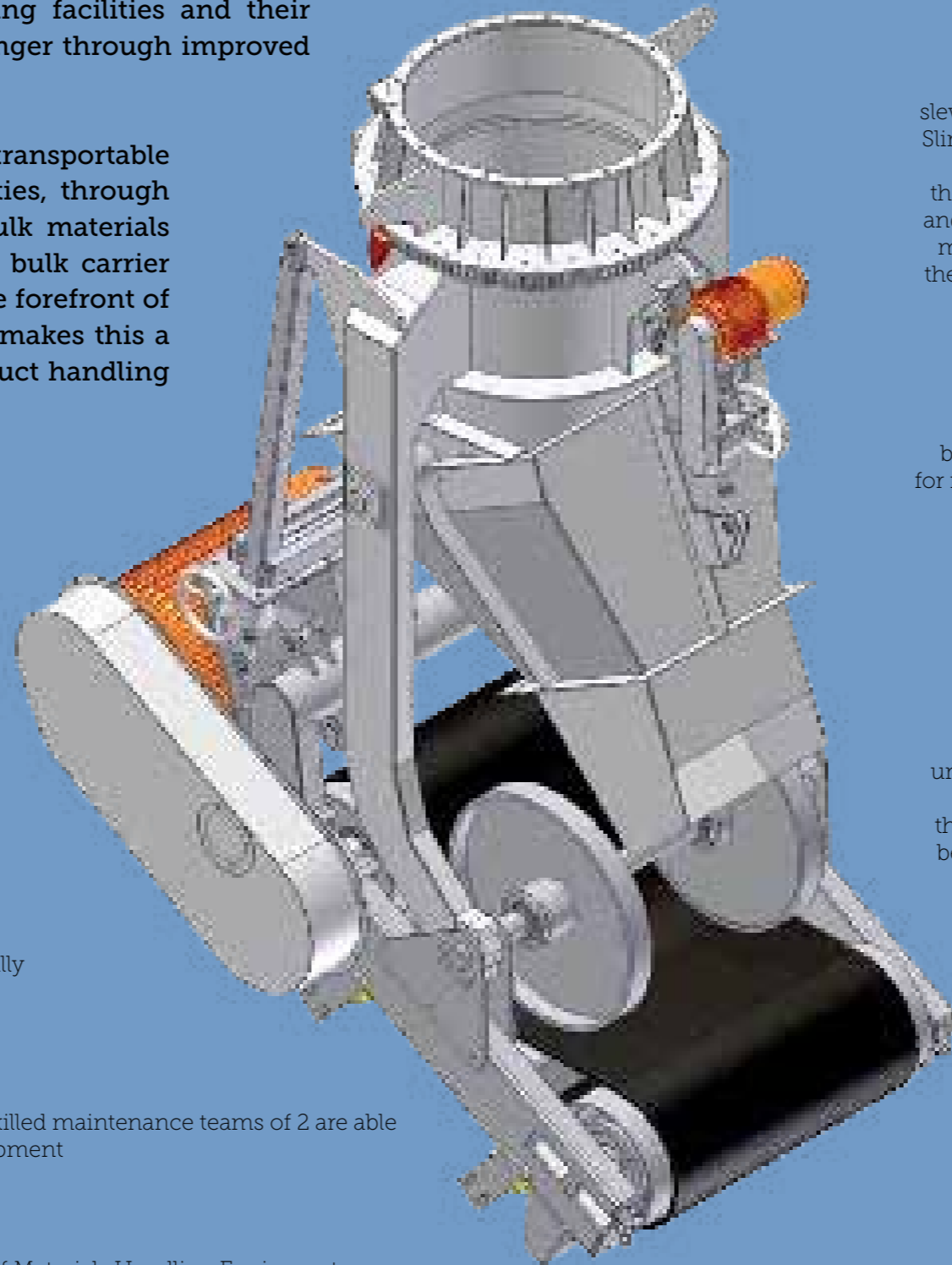

Compact Reliable Slew Drive

A slew drive break motor and pinion drives a slew ring with integral spur gear enabling the Jet Slinger to rotate up to 180 in each direction. The slew brake is automatically applied whenever the motor is de-energised, preventing over-run and creep of the Slinger. A standard off the shelf motor is used to enhance reliability and should the need arise, easy access to replacement parts.

Bypass Chute

HMA Jet Slingers are manufactured with the availability of an optional bypass chute. The bypass chute, when in its active position, allows for material free flow past the end of the retracted Slinger Belt allowing for material positioning directly below the Jet Slinger.

Constant Correct Geometry

Pivoting the Jet Slinger Conveyor about the deflector wheel axle allows for a constant and fixed geometrical relationship between the drive, discharge drum and deflector wheel under all conditions. The outcome is a constant trajectory of material flow onto the belt under the full range of luff angles resulting in reduced belt wear, variation of belt tension and a greatly enhanced throw distance for all ranges of belt speed and materials.

Optional Enhancements

HMA Jet Slingers are manufactured with customer specific requirements in mind. Customer requests as diverse as reduced weight through to altered product settling characteristics can be accommodated. Readily available options include;

- Integral Maintenance Platforms,
- Slinger mounted Trolley and Winch System for maintenance positioning,
- Cable Guidance System from fixed structure from across the slew ring to the Jet Slinger terminal box,
- Remote operational control from deck level of all system functions
- Light weight construction using alternate construction materials,
- Quick coupling to allow the rapid transfer between compatible Telescopic chute and Spoon Chute Combinations.
- Material Deflector and Roller deflector combinations designed to enhance product flight characteristics.



Email: materials@hmagrp.com

AUSTRALIA **Tel:** +61 (0)2 4389 6191
Fax: +61 (0)2 4389 6199

NEW ZEALAND +64 (0)7 850 2610

INDONESIA +62 21 2278 3377

SOUTH AFRICA +27 13 650 9800

HMA GROUP

MATERIALS HANDLING

WEAR SOLUTIONS

FLOW & INDUSTRIAL

INSTRUMENTATION

POWER GENERATION

GEOTECHNICAL

MAT-DS-0051 - DEC 2019

AUSTRALIA - NEW ZEALAND - INDONESIA - SOUTH AFRICA

www.hmagrp.com