

Mini Loader by Dingo Australia



**WACKER
NEUSON**
all it takes!



hire



sales



parts



service

Mini Loader by Dingo Australia

Wheel Loader

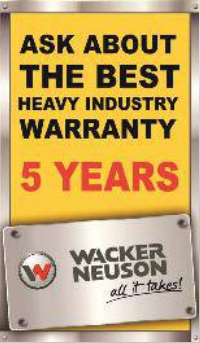

Wacker Neuson 5 years / 5,000 warranty.

2 pump hydraulic system
equals cooler oil - powers both your Dingo and attachments at the same time without robbing power from either.

Grease free maintenance cleaner machine and work environment.

Quick hitch system - for fast and simple change between attachments

Flow Divider - infinite proportional control of flow without restriction

Soft touch controls
Minimise fatigue while providing accurate control

1,835mm lift – lifts into utes & most trucks, tips over fences.

High Flow Auxiliary Hydraulic for powering attachments through the toughest conditions and quick couplers for easy connection to the whole family of attachments.

Large hydraulic oil reservoir.

More oil = cooler oil

Cooler oil = better operation

Better operation = faster jobs, longer machine life.

Tough powder coated finish.

Low centre of gravity increases traction. Improves machine stability. Better operator comfort.

180° access - safer for operators - no risk of being trapped from behind.

Rupture resistant fuel tank full vented cap with true-fill opening for easier refuelling.

All wheel drive system through 4 specifically designed and manufactured drive motors.



Wacker Neuson SM325-24W - Design & Innovation meets Powerful Performance

Designed and manufactured exclusively for Wacker Neuson by Dingo Australia, powered by the EFI petrol engine, the SM325-24W is the ideal platform for worksites, owner-operators and DIY'ers. The lean fuel burn of the Kohler, delivers excellent fuel economy reducing running costs.

Pressure and flow to the wheels and your attachments are the heart of any mini loader - it's how you earn your living. You want the very best - and that's what a SM325-24W provides consistently - day after day, year after year!

Combining the unique hydraulic design of the Wacker Neuson mini-loader with the Kohler EFI, provides the perfect partnership of power, pressure and durability for every application.

The SM325-24W has the most robust chassis on the market - this moves the weight down to the wheels where you need it.

The lower centre of gravity gives you best in class traction and trenching with up to 30% more pull and 30% more push power.

The Wacker Neuson Dingo all-wheel drive SM325-24W is perfect for all terrains.

With the optional narrow wheel and hub set you can quickly change your set up to narrow access whenever you need – as narrow as 780mm – eliminating the need for a second machine.

Achieve more with the best and highest lift for the weight class. Our proven bushing system has no steel on steel wear - which means no grease, no mess resulting in less maintenance and longer machine life!

Protected by our tough powder-coated finish, your SM325-24W will stand up against the harshest of conditions.

Wacker Neuson SM325-24W made by Dingo Australia, working as hard as you do!

Dimensions

Overall width	780 - 1,035 mm
Overall length	1,600 mm
Overall height	1,200 mm
Max operating height 4 in 1	2,650 mm
Turning radius with 4 in 1 bucket	1,300 mm
Angle of departure	25°
Wheel base	800 mm
Ground clearance	135 mm
Dump height standard bucket	1,450 mm
Dump height 4 in 1 bucket	1,835 mm
Reach fully raised 4 in 1 bucket	800 mm
Height to hinge pin	1,940 mm
Machine width 4 in 1 bucket	1,050
Hydraulic reservoir capacity	76 L
Machine mass	862 kg
Warranty	5 years / 5,000hrs

Performance

Engine	Petrol EFI
Engine make	Kohler
Engine horsepower	23 hp
Hydraulic horsepower	23.7 hhp
Hydraulic pumps	2 pumps
Pump sizes	11 & 4cc
Relief pressure (AUX)	3,200 psi (220 bar)
Hydraulic output	47 L/m
Max travel speed	7.5 km / h
Rated lift capacity	325 kg WLL

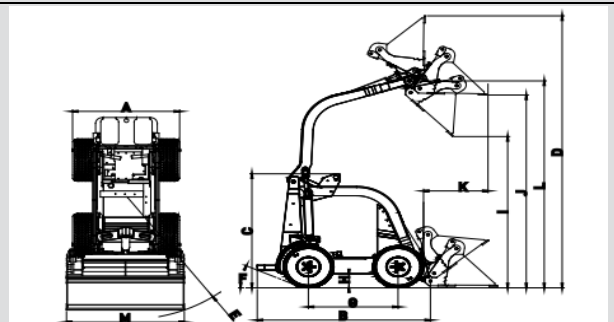

Wacker Neuson SM325-27W- Design & Innovation meets Powerful Performance

Designed and manufactured exclusively for Wacker Neuson by Dingo Australia, powered by the Yanmar diesel engine, the SM325-27W is the ideal platform for worksites, owner-operators and DIY'ers. The lean fuel burn of the Yanmar, delivers excellent fuel economy reducing running costs.

Pressure and flow to the wheels and your attachments are the heart of any mini loader - it's how you earn your living. You want the very best - and that's what a SM325-27W provides consistently - day after day, year after year!

Combining the unique hydraulic design of the Wacker Neuson mini loader with the Yanmar engine, provides the perfect partnership of power, pressure and durability for every application.

The SM325-27W has the most robust chassis on the market - this moves the weight down to the wheels where you need it.

The lower centre of gravity gives you best in class traction and trenching with up to 30% more pull and 30% more push power.

The Wacker Neuson Dingo all-wheel drive SM325-27W is perfect for all terrains.

With the optional narrow wheel and hub set you can quickly change your set up to narrow access whenever you need – as narrow as 780mm – eliminating the need for a second machine.

Achieve more with the best and highest lift for the weight class. Our proven bushing system has no steel on steel wear - which means no grease, no mess resulting in less maintenance and longer machine life!

Protected by our tough powder-coated finish, your SM325-27W will stand up against the harshest of conditions.

Wacker Neuson SM325-27W made by Dingo Australia, working as hard as you do!

Dimensions

Overall width	850 - 1,050 mm
Overall length	1,600 mm
Overall height	1,200 mm
Max operating height 4 in 1	2,080 mm
Turning radius with 4 in 1 bucket	1,300 mm
Angle of departure	25°
Wheel base	800 mm
Ground clearance	135 mm
Dump height standard bucket	1,450 mm
Dump height 4 in 1 bucket	1,835 mm
Reach fully raised 4 in 1 bucket	800 mm
Height to hinge pin	1,940 mm
Machine width 4 in 1 bucket	1,050
Hydraulic reservoir capacity	76 L
Machine mass	984kg
Warranty	5 years / 5,000hrs

Performance

Engine	3TNV76
Engine make	Yanmar
Engine horsepower	27 hp
Hydraulic horsepower	26.8 hhp
Hydraulic pumps	2 pumps
Pump sizes	11 & 4cc
Relief pressure (AUX)	3,200 psi (220 bar)
Hydraulic output	47 L/m
Max travel speed	7.5 km / h
Rated lift capacity	325 kg WLL

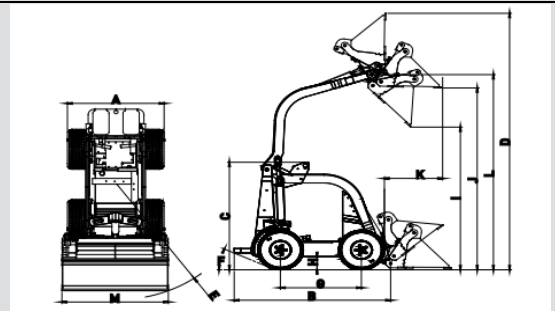

Wacker Neuson SM440-31W- Design & Innovation meets Powerful Performance

Designed and manufactured exclusively for Wacker Neuson by Dingo Australia, powered by the Yanmar diesel engine, the SM440-31W is the ideal platform for worksites, owner-operators and DIY'ers. The lean fuel burn of the Yanmar, delivers excellent fuel economy reducing running costs.

Pressure and flow to the wheels and your attachments are the heart of any mini loader - it's how you earn your living. You want the very best - and that's what a SM440-31W provides consistently - day after day, year after year!

Combining the unique hydraulic design of the Wacker Neuson mini loader with the Yanmar engine, provides the perfect partnership of power, pressure and durability for every application.

The SM440-31W has the most robust chassis on the market - this moves the weight down to the wheels where you need it.

The lower centre of gravity gives you best in class traction and trenching with up to 30% more pull and 30% more push power.

The Wacker Neuson Dingo all-wheel drive SM440-31W is perfect for all terrains.

With the optional narrow wheel and hub set you can quickly change your set up to narrow access whenever you need – as narrow as 780mm – eliminating the need for a second machine.

Achieve more with the best and highest lift for the weight class. Our proven bushing system has no steel on steel wear - which means no grease, no mess resulting in less maintenance and longer machine life!

Protected by our tough powder-coated finish, your SM440-31W will stand up against the harshest of conditions.

Wacker Neuson SM440-31W made by Dingo Australia, working as hard as you do!

Dimensions

Overall width	850 - 1,050 mm
Overall length	1,600 mm
Overall height	1,225 mm
Max operating height 4 in 1	2,675 mm
Turning radius with 4 in 1 bucket	1,300 mm
Angle of departure	25°
Wheel base	800 mm
Ground clearance	170 mm
Dump height standard bucket	1,550 mm
Dump height 4 in 1 bucket	1,870 mm
Reach fully raised 4 in 1 bucket	800 mm
Height to hinge pin	1,985 mm
Machine width 4 in 1 bucket	1,050
Hydraulic reservoir capacity	76 L
Machine mass	1,080 kg
Warranty	5 years / 5,000hrs

Performance

Engine	3TNV76
Engine make	Yanmar
Engine horsepower	27 hp
Hydraulic horsepower	30.75 hhp
Hydraulic pumps	3 pumps
Pump sizes	6, 8.4 & 8.4cc
Relief pressure (AUX)	3,400 psi (235 bar)
Hydraulic output	73 L/m
Max travel speed	9.5 km / h
Rated lift capacity	440 kg WLL

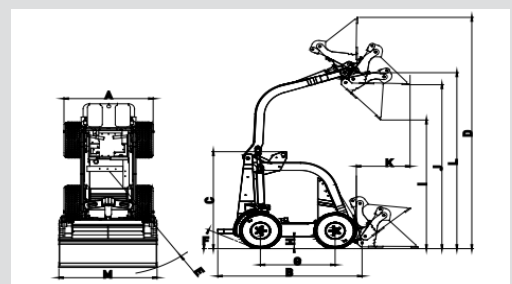

Mini Loader by Dingo Australia Track Loader

Wacker Neuson 5 years / 5,000 warranty.



2 pump hydraulic system

equals cooler oil - powers both your Dingo and attachments at the same time without robbing power from either.

Flow Divider -

infinite proportional control of flow without restriction

Grease free maintenance

cleaner machine and work environment.

Quick hitch system -

for fast and simple change between attachments

1,835mm lift – lifts into utes & most trucks, tips over fences.

Soft touch controls

Minimise fatigue while providing accurate control

Low centre of gravity

increases traction. Improves machine stability. Better operator comfort.

180° access -

safer for operators - no risk of being trapped from behind.

High Flow Auxiliary Hydraulic

for powering attachments through the toughest conditions and quick couplers for easy connection to the whole family of attachments.

Large hydraulic oil reservoir.

More oil = cooler oil
Cooler oil = better operation
Better operation = faster jobs, longer machine life.

Tough powder coated finish.

Rupture resistant fuel tank

full vented cap with true-fill opening for easier refuelling.



Wacker Neuson SM325-24T - Design & Innovation meets Powerful Performance

Designed and manufactured exclusively for Wacker Neuson by Dingo Australia, powered by the EFI petrol engine, the SM325-24T is the ideal platform for worksites, owner-operators and DIY'ers. The lean fuel burn of the Kohler, delivers excellent fuel economy reducing running costs.

Pressure and flow to the track and your attachments are the heart of any mini loader - it's how you earn your living. You want the very best - and that's what a SM325-24T provides consistently - day after day, year after year!

Combining the unique hydraulic design of the Wacker Neuson mini-loader with the Kohler EFI, provides the perfect partnership of power, pressure and durability for every application.

The SM325-24T has the most robust chassis on the market - this moves the weight down to the track where you need it.

The lower centre of gravity gives you best in class traction and trenching with up to 30% more pull and 30% more push power.

The Wacker Neuson tracked mini loader is ideal for sensitive or difficult ground conditions. Ideally suited for working on grass, in sand or muddy conditions the Wacker Neuson tracked mini loaders are a versatile loader.

Achieve more with the best and highest lift for the weight class. Our proven bushing system has no steel on steel wear - which means no grease, no mess resulting in less maintenance and longer machine life!

Protected by our tough powder-coated finish, your SM325-24T will stand up against the harshest of conditions.

Wacker Neuson SM325-24T made by Dingo Australia, working as hard as you do!

Dimensions

Overall width	840- 1,035 mm
Overall length	1,600 mm
Overall height	1,200 mm
Max operating height 4 in 1	2,650 mm
Turning radius with 4 in 1 bucket	1,300 mm
Angle of departure	25°
Wheel base	800 mm
Ground clearance	135 mm
Dump height standard bucket	1,450 mm
Dump height 4 in 1 bucket	1,835 mm
Reach fully raised 4 in 1 bucket	800 mm
Height to hinge pin	1,940 mm
Machine width 4 in 1 bucket	1,050
Hydraulic reservoir capacity	76 L
Machine mass	989 kg
Warranty	5 years / 5,000hrs

Performance

Engine	Petrol EFI
Engine make	Kohler
Engine horsepower	23 hp
Hydraulic horsepower	23.7 hhp
Hydraulic pumps	2 pumps
Pump sizes	11 & 4cc
Relief pressure (AUX)	3,200 psi (220 bar)
Hydraulic output	47 L/m
Max travel speed	7.5 km / h
Rated lift capacity	325 kg WLL

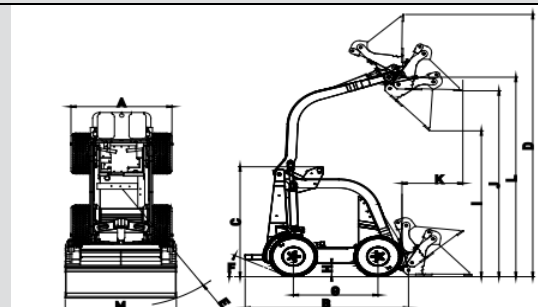

Wacker Neuson SM325-27T - Design & Innovation meets Powerful Performance

Designed and manufactured exclusively for Wacker Neuson by Dingo Australia, powered by the Yanmar diesel engine, the SM325-27T is the ideal platform for worksites, owner-operators and DIY'ers. The lean fuel burn of the Yanmar, delivers excellent fuel economy reducing running costs.

Pressure and flow to the track and your attachments are the heart of any mini loader - it's how you earn your living. You want the very best - and that's what a SM325-27T provides consistently - day after day, year after year!

Combining the unique hydraulic design of the Wacker Neuson mini-loader with the Yanmar engine, provides the perfect partnership of power, pressure and durability for every application.

The SM325-27T has the most robust chassis on the market - this moves the weight down to the track where you need it.

The lower centre of gravity gives you best in class traction and trenching with up to 30% more pull and 30% more push power.

The Wacker Neuson mini loader is ideal for sensitive or difficult ground conditions. Ideally suited for working on grass, in sand or muddy conditions the Wacker Neuson mini track loaders are a versatile loader.

Achieve more with the best and highest lift for the weight class. Our proven bushing system has no steel on steel wear - which means no grease, no mess resulting in less maintenance and longer machine life!

Protected by our tough powder-coated finish, your SM325-27T will stand up against the harshest of conditions.

Wacker Neuson SM325-27T made by Dingo Australia, working as hard as you do!

Dimensions

Overall width	850 - 1,050 mm
Overall length	1,600 mm
Overall height	1,200 mm
Max operating height 4 in 1	2,080 mm
Turning radius with 4 in 1 bucket	1,300 mm
Angle of departure	25°
Wheel base	800 mm
Ground clearance	135 mm
Dump height standard bucket	1,450 mm
Dump height 4 in 1 bucket	1,835 mm
Reach fully raised 4 in 1 bucket	800 mm
Height to hinge pin	1,940 mm
Machine width 4 in 1 bucket	1,050
Hydraulic reservoir capacity	76 L
Machine mass	1,093 kg
Warranty	5 years / 5,000hrs

Performance

Engine	3TNV76
Engine make	Yanmar
Engine horsepower	27 hp
Hydraulic horsepower	26.8 hhp
Hydraulic pumps	2 pumps
Pump sizes	11 & 4cc
Relief pressure (AUX)	3,200 psi (220 bar)
Hydraulic output	47 L/m
Max travel speed	7.5 km / h
Rated lift capacity	325 kg WLL

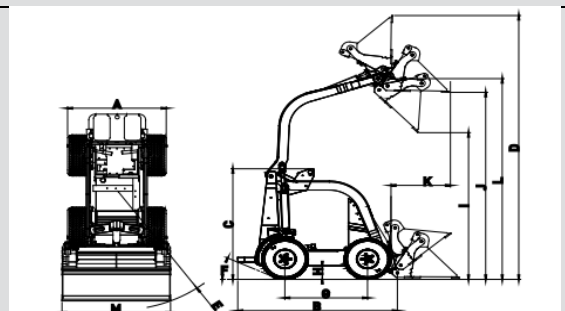

Wacker Neuson SM440-31T- Design & Innovation meets Powerful Performance

Designed and manufactured exclusively for Wacker Neuson by Dingo Australia, powered by the Yanmar diesel engine, the SM440-31T is the ideal platform for worksites, owner-operators and DIY'ers. The lean fuel burn of the Yanmar, delivers excellent fuel economy reducing running costs.

Pressure and flow to the track and your attachments are the heart of any mini loader - it's how you earn your living. You want the very best - and that's what a SM440-31T provides consistently - day after day, year after year!

Combining the unique hydraulic design of the Wacker Neuson mini loader with the Yanmar engine, provides the perfect partnership of power, pressure and durability for every application.

The SM440-31T has the most robust chassis on the market - this moves the weight down to the track where you need it.

The lower centre of gravity gives you best in class traction and trenching with up to 30% more pull and 30% more push power.

The Wacker Neuson mini loader is ideal for sensitive or difficult ground conditions. Ideally suited for working on grass, in sand or muddy conditions the Wacker Neuson mini track loaders are a versatile loader.

Achieve more with the best and highest lift for the weight class. Our proven bushing system has no steel on steel wear - which means no grease, no mess resulting in less maintenance and longer machine life!

Protected by our tough powder-coated finish, your SM440-31T will stand up against the harshest of conditions.

Wacker Neuson SM440-31T made by Dingo Australia, working as hard as you do!

Dimensions

Overall width	850 - 1,050 mm
Overall length	1,600 mm
Overall height	1,225 mm
Max operating height 4 in 1	2,675 mm
Turning radius with 4 in 1 bucket	1,300 mm
Angle of departure	25°
Wheel base	800 mm
Ground clearance	170 mm
Dump height standard bucket	1,550 mm
Dump height 4 in 1 bucket	1,870 mm
Reach fully raised 4 in 1 bucket	800 mm
Height to hinge pin	1,985 mm
Machine width 4 in 1 bucket	1,050
Hydraulic reservoir capacity	76 L
Machine mass	1,169 kg
Warranty	5 years / 5,000hrs

Performance

Engine	3TNV76
Engine make	Yanmar
Engine horsepower	27 hp
Hydraulic horsepower	30.75 hhp
Hydraulic pumps	3 pumps
Pump sizes	6, 8.4 & 8.4cc
Relief pressure (AUX)	3,400 psi (235 bar)
Hydraulic output	73 L/m
Max travel speed	9.5 km / h
Rated lift capacity	440 kg WLL

