



# G series

145 ▾ 193 ▾ 241 ▾ 333 ▾ 429

W M P C



Are you're looking for the best value CNC machine, with state-of-the-art automation and features. The **G-Series** (a.k.a. the Pro-Series) is our solution for heavy CNC production in wood, plastic, composites or non-ferrous metals – with the nominal footprint and affordability of a fixed table moving gantry design. Tailored to your application, we offer multiple spindles, drill head configurations, pendulum processing and an array of automation options for nested-based panel processing. All with the reliability and performance found only from the industry leader, C.R. Onsrud.



**C.R. ONSRUD**  
AMERICAN-MADE CNC MACHINERY

Real. American. Originals.

*You need CNC machines with the speed, accuracy, reliability, durability and flexibility to grow your business. The G-Series delivers that and more.*

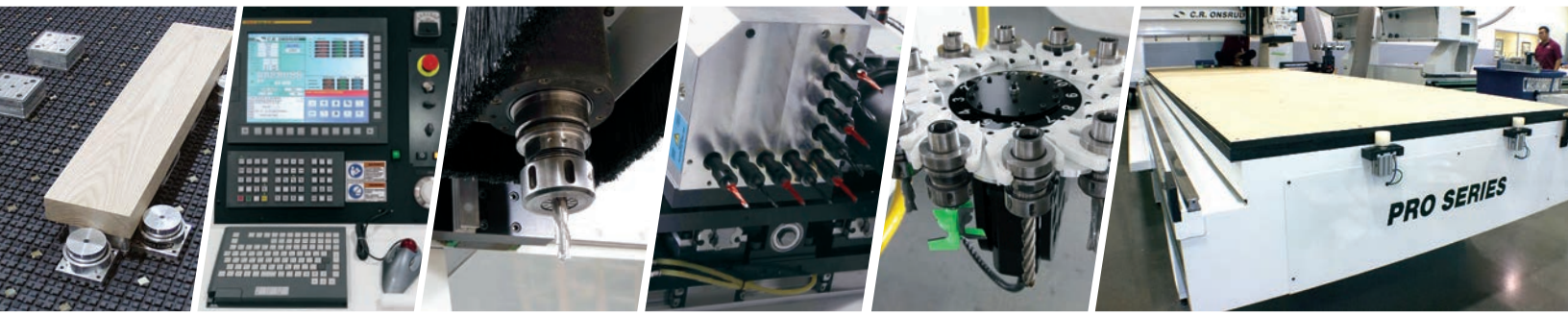

145G		Table		Overall	
	Inches	Metric		Inches	Metric
X	145"	3683mm	L	230"	5842mm
Y	61"	1549mm	W	136"	3454mm
Z	11"	279mm	H	90"	2286mm

193G		Table		Overall	
	Inches	Metric		Inches	Metric
X	193"	4902mm	L	278"	7061mm
Y	61"	1549mm	W	136"	3454mm
Z	11"	279mm	H	90"	2286mm

241G		Table		Overall	
	Inches	Metric		Inches	Metric
X	241"	6121mm	L	325"	8255mm
Y	61"	1549mm	W	136"	3454mm
Z	11"	279mm	H	90"	2286mm

333G		Table		Overall	
	Inches	Metric		Inches	Metric
X	333"	8458mm	L	420"	10668mm
Y	61"	1549mm	W	136"	3454mm
Z	11"	279mm	H	90"	2286mm

429G		Table		Overall	
	Inches	Metric		Inches	Metric
X	429"	10897mm	L	513"	13030mm
Y	61"	1549mm	W	136"	3454mm
Z	11"	279mm	H	90"	2286mm

429 and longer/wider machines fall into our Custom G-Series.

Available in 3 or 5 Axis Configurations!

### G-Series Features:

	Standard	Optional
Spindle (S6):	18HP / 13.5kW	24HP / 18kW
Max RPM:	24,000	24,000
Control:	FANUC 0i	Osai OPEN, B&R
Tool Management:	12-Pos. Rotary	(2) 12-Pos. Rotary
Material Control:	Vacuum Holding	Mechanical
Material Handling:	Manual	Automatic Infeed / Outfeed

Additional Items:	Aggregate Capable	Air Blast / Cold Air Blast
	Auto Tool Measurement	C-Axis
	Drill Block (4,9,14,18, 24)	Labeling
	Gantry Shroud	Linear Scales
	Multiple Spindles	Probing
	Robotics Integration	Roller Hold-Down
	Automatic Machine Lubrication	
	(Tool MQL) Minimum Quantity Lubrication	

Additional options available upon request. All features are subject to change.

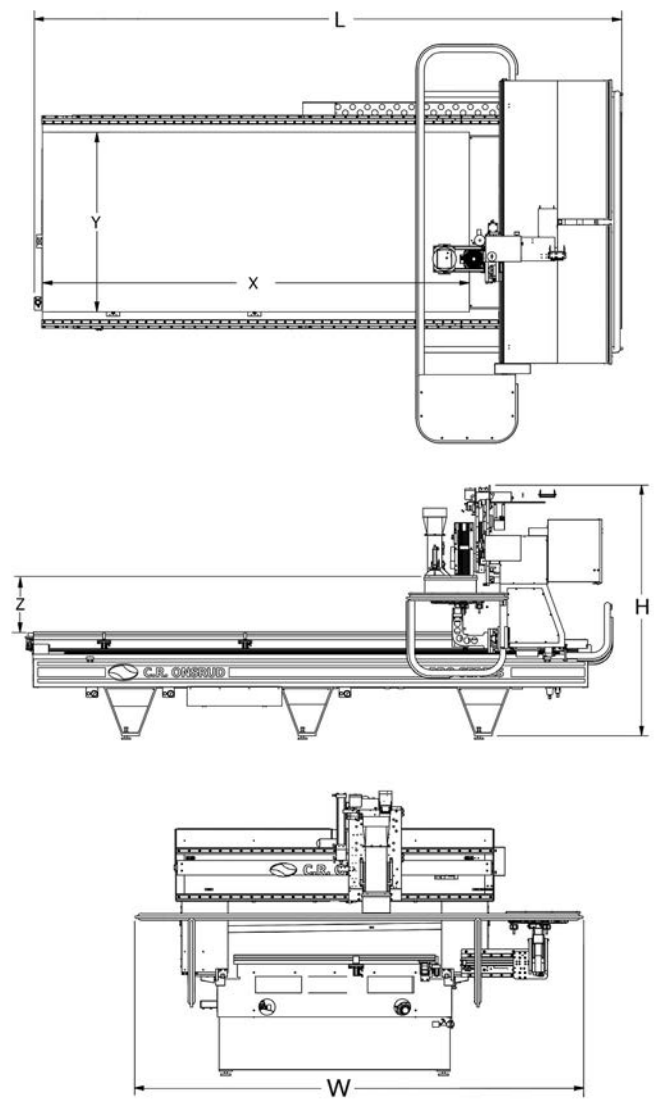

Find Your Next CNC Machine @ [www.cronsrud.com](http://www.cronsrud.com)

120 Technology Drive • Troutman, North Carolina 28166 • 704.508.7000

**C.R. Onsrud** is a proud American manufacturer which designs, engineers and builds tailor-made CNC machinery