



ICE VISION ION

GIOIA



SOLUZIONI D'ARREDO PER FOOD & BEVERAGE

Il freddo e' il nostro habitat

GIOIA



G



Gelato

i



Pasticceria
Pastry
Konditorei
Pâtisserie

O



Pralineria
Praline
Pralinen
Pralinerie

i



Caldo a secco
Dry heat
Trockene Wärme
Chaud à sec

a



Bagno maria
Bain marie
Wasserbad
Bain-marie

IT

Modello di vetrina dalla vasta gamma di servizi: dal gelato alla pasticceria, pralineria e gastronomia. Il design della GIOIA rappresenta il carattere giovane e dinamico di Itai Proget.

Scocca monoblocco con isolamento in poliuretano spessore mm 60, vasca in acciaio inox AISI 304.

Illuminazione a LED.

Alzata vetri riscaldati anticondensa, apertura del vetro frontale a compasso, chiusura lato servizio con tendina auto avvolgente o scorrevoli in plexiglass.

Refrigerazione ventilata con doppio evaporatore.

Doppio compressore ermetico (nei modelli 18 e 24) per ottime prestazioni frigo, con basso livello di rumorosità. Optional compressore 400/3.

Unità condensatrice estraibile per una manutenzione semplice e veloce.

Sbrinamento automatico ultrarapido, ad inversione di ciclo.

Quadro comandi elettronico per la regolazione della temperatura.

classe climatica 7 (35°/ 75% UR).

EN

Display case model offering a wide range of services: from ice-cream to pastries, candies to delicatessens. GIOIA design represents the young, dynamic character of Itai Proget.

One-piece shell with 60 mm-thick polyurethane insulation, AISI 304 stainless steel tank.

LED lighting.

Anti-condensation heated glass superstructure, vent-opening front glass, service side closure with wraparound curtain or sliding Plexiglass doors.

Ventilated refrigeration with double evaporators.

Double hermetic compressor (in models 18 and 24) for optimal refrigeration performance with low noise level. Optional compressor 400/3.

Removable condensing unit for easier, faster maintenance.

Automatic ultra-fast reverse cycle defrost.

Electronic control panel for temperature adjustment.

Climate class 7 (35°/ 75% UR).

DE

Die vielseitige Vitrine mit verschiedenen Einsatzmöglichkeiten: geeignet für Eisdiele, Konditorei, Konfiserie und Gastronomie. Das Design von GIOIA verkörpert den jungen und dynamischen Geist von Itai Proget.

Monoblock-Gehäuse mit 60 mm dicker Polyurethan-Hartschaumisolierung, Edelstahlwanne AISI 304.

LED-Beleuchtung.

Beheizter Glasaufsatz mit Wärmedämmverglasung, Frontscheibe mit Klappöffnung, Schließung der Bedienerseite mit Thermorollo oder Plexiglas-Schiebescheibe.

Umluftkühlung mit zwei Verdampfern.

Doppelter hermetischer Kompressor (für Modelle 18 und 24) für erstklassige Kühlleistung, extrem geräuscharm. Optional erhältlicher Kompressor 400/3.

Entnehmbares Verflüssigeraggregat für einfache und rasche Wartung.

Ultraschnelle automatische Abtauung durch Zyklusinversion.

Elektronisches Schaltpult zum Einstellen der Temperatur.

Klimaklasse 7 (35°/ 75% UR).

FR

Modèle de vitrine permettant une vaste gamme de services : de la glace à la pâtisserie, des chocolats à la gastronomie. Le design de GIOIA représente le caractère jeune et dynamique d'Itai Proget.

Châssis monobloc avec isolation en polyuréthane épaisseur 60 mm, cuve en acier inox AISI 304.

Éclairage à LED.

Montant vitres réchauffées anti-condensation, ouverture de la vitre frontale par compas, fermeture côté service avec rideau à enroulement automatique ou coulissant en plexiglas.

Réfrigération ventilée avec double évaporateur.

Double compresseur hermétique (dans les modèles 18 et 24) pour des performances de réfrigération optimales, avec niveau de bruit bas.

Compresseur 400/3 optionnel.

Unité de condensation amovible pour un entretien simple et rapide.

Dégivrage automatique ultra rapide, à cycle inversé.

Tableau de commandes électronique pour le réglage de la température.





Classe climatique 7 (35°/ 75% UR).



REFRIGERAZIONE VENTILATA
VENTILATED REFRIGERATION
UMLÜFTKÜHLUNG
RÉFRIGÉRATION VENTILÉE



DATI TECNICI / TECHNICAL DATA / TECHNISCHE DATEN / DONNEES TECHNIQUES

| MOD. |  L P H  | | | |  L P H  | | | |  [°C] | POTENZA COMPRESSORE / POWER COMPRESSOR PUISSANCE COMPRESSEUR / LEISTUNG VERDICHTER | | | | | | |
|----------------------------|---|--|--|---|--|--|--|------------|---|---|--------|------|----------|------|------|-----------|
| | Monofase / Single-phase / Einphasig / Monophasé | | | Trifase / Three-phase / Dreiphasig / Triphasé | | | N. Classe climatica No. Climate class Klimaklasse N° Classe climatique N° | | | | | | | | | |
| | Tensione Supply Spannung Tension | Regime Output Verhältnis Régime | Sbrinamento In Defrost Zeitgesteuerte Dégivrage | Tensione Supply Spannung Tension | Regime Output Verhältnis Régime | Sbrinamento In Defrost Zeitgesteuerte Dégivrage | | [°C/%UR] | | | | | | | | |
| [cm] | [cm] | [cm] | [kg] | [cm] | [cm] | [cm] | [kg] | [V/Hz] | [Kw] | [Kw] | [V/Hz] | [Kw] | [Kw] | | | |
| GIOIA GELATO 12 | 112 | 106 | 122 138 | 235 245 | 127 | 121 | 156 156 | 270 280 | -16 / -18 | 230/1/50 | 1.51 | 2.15 | 400/3/50 | 1.3 | 2.52 | 7 (35/75) |
| GIOIA GELATO 18 | 162 | 106 | 122 138 | 325 335 | 178 | 121 | 156 156 | 357 367 | -16 / -18 | 230/1/50 | 2.08 | 3.53 | 400/3/50 | 1.97 | 3.87 | 7 (35/75) |
| GIOIA GELATO 24 | 214 | 106 | 122 138 | 390 400 | 228 | 121 | 156 156 | 470 480 | -16 / -18 | 230/1/50 | 2.5 | 3.8 | 400/3/50 | 2.8 | 5.1 | 7 (35/75) |

H122

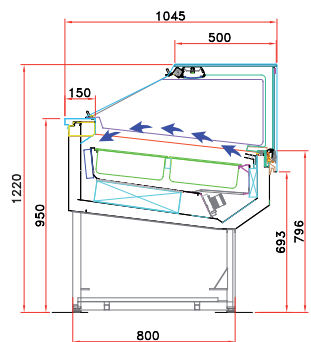

Base / Basic
Basis / Base

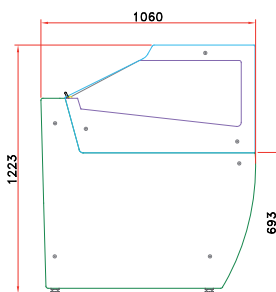

Pannellata / With panels
Mit Paneelen / Avec des panneaux

H138

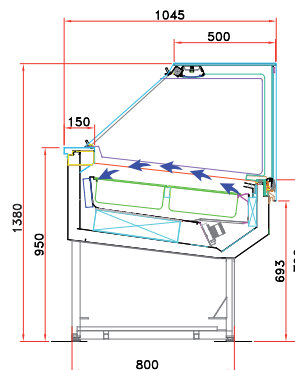

Base / Basic
Basis / Base

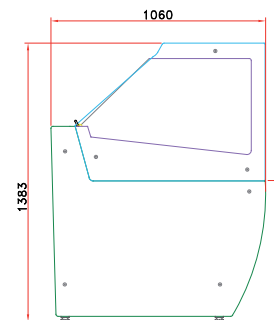

Pannellata / With panels
Mit Paneelen / Avec des panneaux

GIOIA GELATO 12

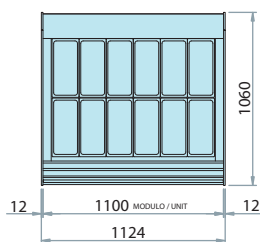

GIOIA GELATO 18

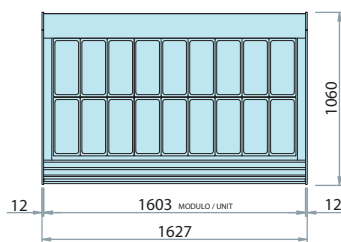

GIOIA GELATO 24

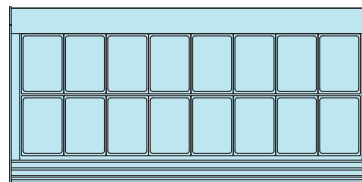
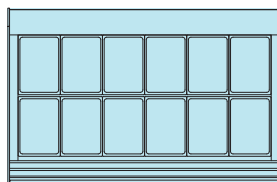
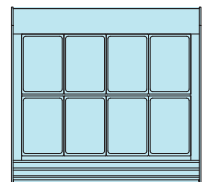
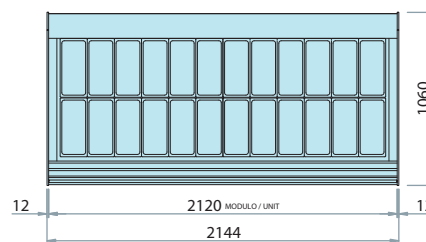

STANDARD L x P x H
360 x 165 x 120 [5Lt.]

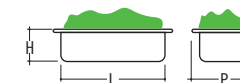

LARGE L x P x H
360 x 250 x 80 [7Lt.]
360 x 250 x 120 [10Lt.]



DI SERIE / STANDARD / DI SERIE / SÉRIE

Sbrinamento auto. elettr. / Automatic electric defrost / Zeitgesteuerte abtauautomatik / Dégivrage automatique
Unità di controllo elettr. / Electronic control unit / Elektronische steuereinheit / Unité de contrôle électronique
Fluido refrigerante R404A / R404A refrigerant gas / Kühlgas R404A / Gaz réfrigérant R404A

COLORI / COLOURS / FARBEN / COULEURS



Le vetrine possono essere personalizzate nei colori RAL in commercio.
The showcase can be customized in colors according to available RAL.
Die Vitrinen können in handelsüblichen RAL-Farben gestaltet werden.
Les vitrines peuvent être personnalisées selon les coloris RAL dans le commerce.



Italian Gelato Concepts Pty Limited
Unit 1, 37 Mortimer Road
Acacia Ridge Qld 4110

Bris Office: +61 [0] 7 3162 7724
Syd Office +61 [0] 2 8311 9701
Email: info@italiangelato.com.au

www.italiangelato.com.au



SOLUZIONI D'ARREDO PER FOOD & BEVERAGE

AF DESIGN 0118 - ICEVISION