

EKH-145

Heat Shrink Machine

Code: 2136

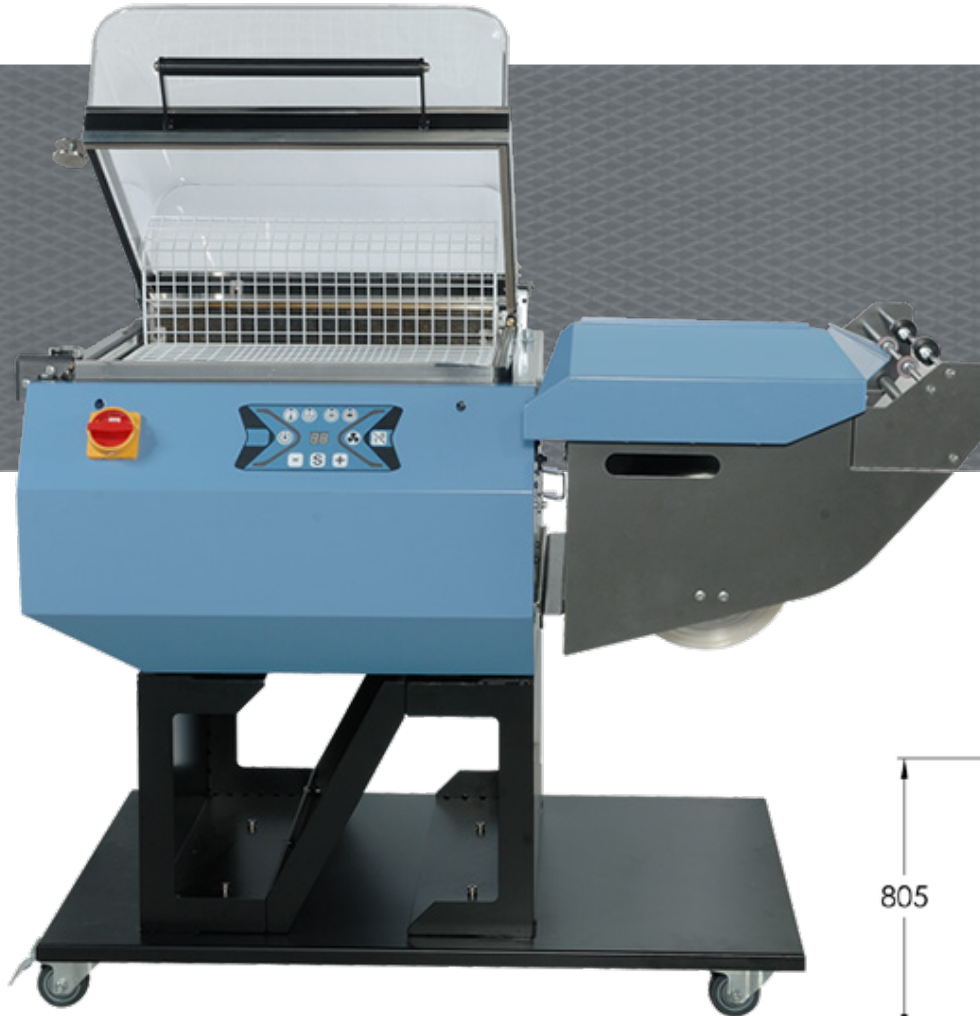

SPECIFICATIONS

Power Supply	220V/230V/240V, 50/60HZ, 1-PH
Max. Power Consumption	3.77Kw
Effective Power Consume	1.6-2.3KW
Sealing Dimension	550mm x 415mm
Max. Packaging Height	300mm
Max. Film Dimension	600mm x 250mm

FEATURES

- Digital control panel to easy operating.
- Digital control panel to clear inform error message.
- Stable film punctures design to allow film air hole punch accurate and precision.
- Special coated shrinking chamber, very convenient clean surface.
- Efficient air cooling system to allow long working hours.

