



www.bandsaw.com.tw



### 鎂佳機械工業股份有限公司 MEGA MACHINE CO.,LTD.

台灣 · 41154 台中市太平區工業路180號  
No.180, Industrial Road, Tai-ping District, Taichung City, 41154, Taiwan R. O. C.  
www.bandsaw.com.tw  
Tel:+886-4-22712877(Rep.) Fax: +886-4-22715016  
E-Mail: sales@bandsaw.com.tw

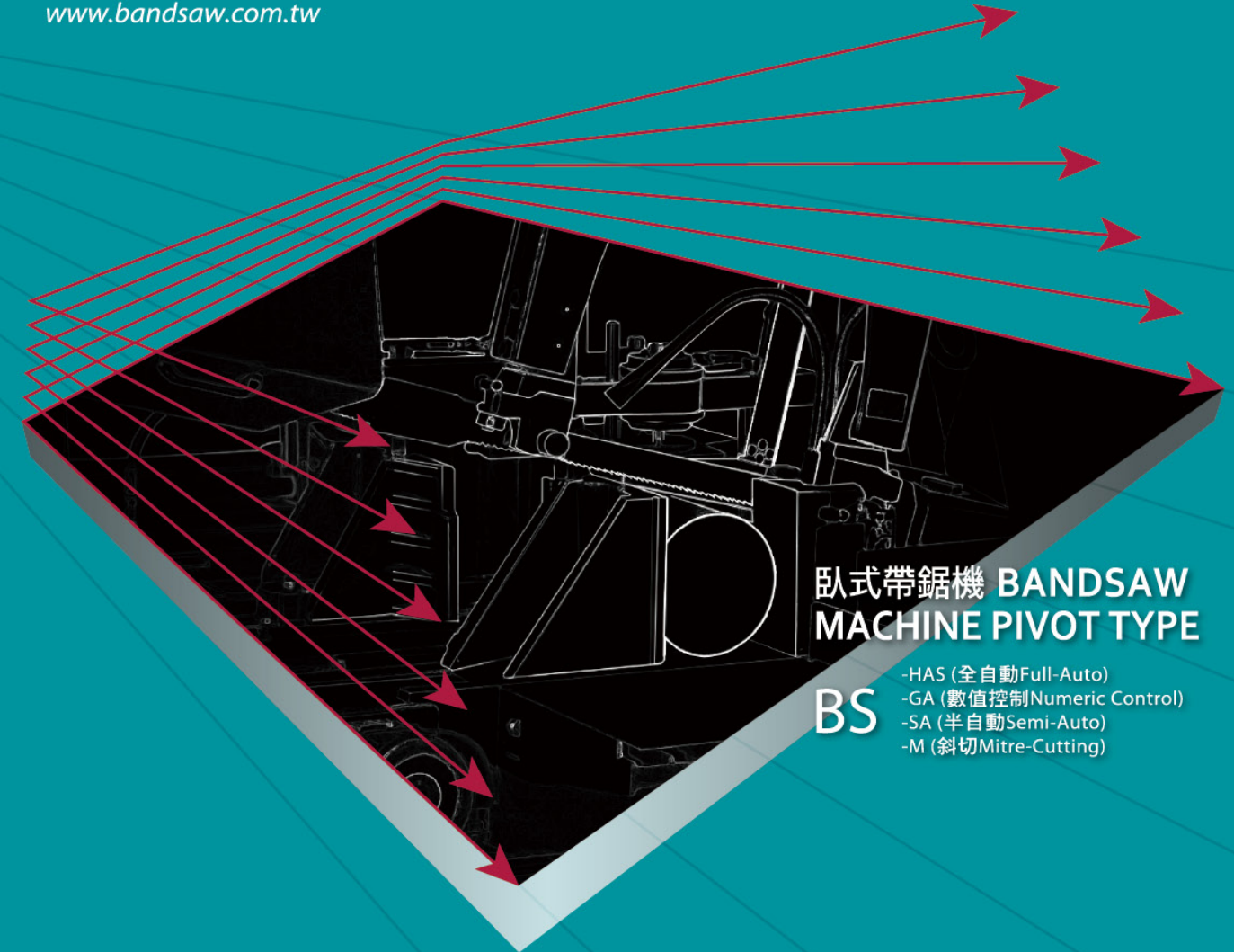

### 臥式帶鋸機 BANDSAW MACHINE PIVOT TYPE

BS

- HAS (全自動Full-Auto)
- GA (數值控制Numeric Control)
- SA (半自動Semi-Auto)
- M (斜切Mitre-Cutting)



Official Website

2021.03  
886-4-2296-5959

Keep Improving & Quality Oriented -Skillful engineering and imaginative design give every MEGA Band Saw Machine exceptional cutting capacity.  
不斷創新與精進&嚴格執行品質要求-以操作者為出發點的設計,並追求完美的品質



# BS-SA 半自動油壓臥式帶鋸機 (手動進料) SEMI-AUTOMATIC HORIZONTAL BANDSAWS (MANUAL BAR FEED)



## 中央控制面板

所有機器操作元件集中化到控制面板，方便操作。

### CENTRALIZED CONTROL PANEL

All the machine controls are centralized on a control panel, for the operator's convenience.



## 油壓快速作動夾鉗

夾鉗由齒排連結油壓驅動，容易調整符合材料大小尺寸。

### HYDRAULIC QUICK-ACTION VISE

Vises are hydraulic operated. Tooth-rack and push-jaw features. Easily adjusted to accommodate stock size.

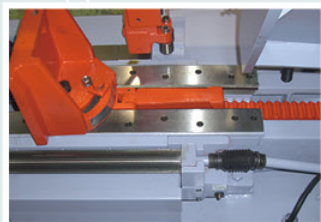

## 浮動滾輪機構

使用搖桿設定夾鉗及浮動滾輪，當夾鉗開啟時滾輪上升，藉著手輪輕鬆地送料前進。

### FLOATING ROLLER FEED MECHANISM

Cylinder lifts stock a little to make feeding smoothly with floating roller.



## 自動抬頭高度控制 400SA/450SA/1830

只要設定控制鈕，便能自動控制鋸架抬高高度，方便材料的拿取。

### AUTOMATIC HEAD ELEVATION CONTROL

Saw frame will raise automatically up to the height that you preset by a dial knob on the control panel, needed to clear the material being cut.

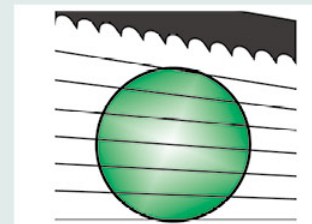

## 獨立的進給控制

獨立的進給控制系統由溫度及壓力補償所建立確保最大切削效能，進給控制能維持工件穩定切削。

### UNIQUE FEED-RATE CONTROL

This unique feed-rate control system with built in temperature and pressure compensation ensures maximum cutting performance. The feed rate control will maintain a constant cutting rate.



## 動力鋼刷輪

動力鋼刷輪由強力冷卻液噴刷，確保鋸刃切削時無鐵屑。

### POWER-DRIVEN SAW-BAND BRUSH

A power-driven saw-band brush, continually flushed by a cutting fluid spout, keeps the blade and saw guides free of chips for smoother cutting. A flush hose is available for washing chips and debris away from the cutting area.



## 快速螺旋式碳化鎢導鋸

本機全部採用碳化鎢導鋸片來導引鋸帶，使鋸帶能具有剛性和直線精度。而碳化鎢的鬆緊則採用螺旋來操作，不但省力，而且快速，操作者要更換新的鋸帶時使用此一設計可說是輕鬆容易。

### QUICK-ADJUSTING CARBIDE SAWBAND GUIDES

For the replacement of the saw blade or the repositioning of the guide arms, two levers are incorporated in the saw guides to allow these operations to be carried out quickly and efficiently.



## 鋸片旋轉偵測系統 (選配)

此一裝置能保護鋸片於過負載切削時免於折損，因為過附載切削，鋸片會卡住於材料中，它能立即偵知停機，而避免繼續下降機台而折斷鋸片。另外，鋸片沒張緊或是意外折斷亦能自動停機。

### IDLE WHEEL MOTION DETECTOR (OPTIONAL)

The device not only can protect the saw blade from damage if the blade overloads during cutting, but will also shut off the machine if the blade breaks.



# BS-400SA/450SA/1830

半自動油壓臥式帶鋸機 (手動進料)

SEMI-AUTOMATIC HORIZONTAL BANDSAWS (MANUAL BAR FEED)



## 規格表 Specifications

規格 / 機型 SPEC. / MODEL		BS - 400 SA	BS - 450 SA	BS - 1830
鋸切能力 Cutting Capacity	mm	● 400 ■ 400W X 310H	● 460 ■ 460W X 407H	● 460 ■ 760W X 407H
	in	● 16 ■ 16W X 12H	● 18 ■ 18W X 16H	● 18 ■ 30W X 16H
斜切 Mitre Cutting	mm	280 ( At 45° ) ( 選配 Opt.)	320 ( At 45° ) ( 選配 Opt.)	N/A
鋸帶尺寸 Blade Size	mm	34W X 1.1t X 4115L	41W X 1.30t X 4670L	41W X 1.30t X 5300L
	in	1.33W X 0.043t X 162L	1.61W X 0.051t X 184L	1.61W X 0.051t X 209L
鋸帶速度 Blade Speed	M/min	25,32,42,55,70,80 無段變速 Variable Speed 20 - 80 ( 選配 Opt. )		
	F/min	82,105,138,180,230,260 無段變速 Variable Speed 65 - 260 ( 選配 Opt. )		
馬達 Motor Output	HP	鋸帶 Blade 5 ; 油壓 Hyd.1 ; 冷卻 Coolant 1/8	鋸帶 Blade 7.5 ; 油壓 Hyd.2 ; 冷卻 Coolant 1/8	鋸帶 Blade 7.5 ; 油壓 Hyd. 2 ; 冷卻 Coolant 1/8
	KW	鋸帶 Blade 3.75; 油壓 Hyd.0.75; 冷卻 Coolant 0.1	鋸帶 Blade 5.6; 油壓 Hyd.1.5; 冷卻 Coolant 0.1	鋸帶 Blade 5.6; 油壓 Hyd.1.5 ; 冷卻 Coolant 0.1
封箱尺寸 (L X W X H) Shipping Volume	mm	2210 X 1190 X 1640	2450 X 1270 X 1890	2790 X 1300 X 1830
	ft	7.25 X 3.9 X 5.38	8 X 4.1 X 6.2	9.1 X 4.2 X 6
淨重 / 毛重 N.W. / G.W.	kg	1060 / 1275	1500 / 1750	1650 / 1910
	lb	2330 / 2805	3300 / 3850	3630 / 4205

### 標準配備 Standard Equipment

工具箱 Tools with tool box	1 只 set
1.5M(5ft.)長滾輪台 Long roller table with vertical rollers	1 台 set
清屑鋼刷輪 Band-cleaning wire brush	1 件 pc
鋸帶 Bandsaw blade	1 條 pc
操作手冊 Instruction manual	1 本 copy

### 選擇配備 Optional Equipment

1. 自動清屑系統 Automatic chip conveyor.
2. 鋸帶無段變速 Variable blade speed drive.
3. 45° 斜切裝置 Mitre cutting device.
4. 外加滾輪台 Additional spare roller table.

## 全自動油壓臥式帶鋸機 FULL AUTOMATIC HORIZONTAL BANDSAWS

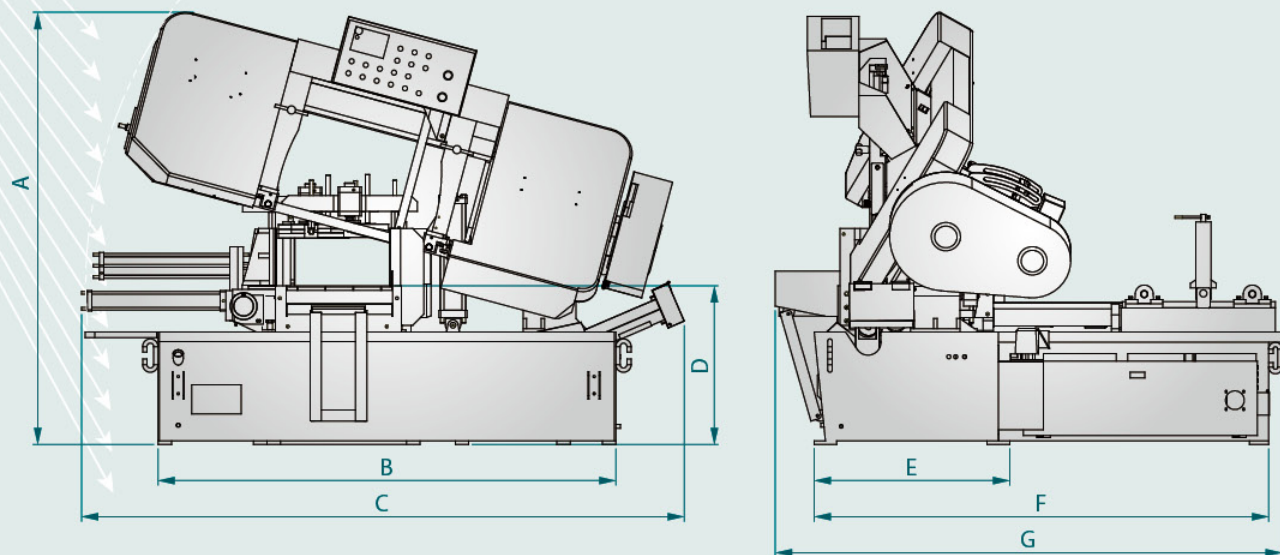

規格 / 機型 SPEC. / MODEL	單位 UNIT	A	B	C	D	E	F	G
BS-250HAS/GA	mm	1653	1550	2190	593	740	1772	1956
	inch	65.08	61.02	86.22	23.35	29.13	69.76	77.01
BS-300HAS/GA	mm	1761	1550	2199	593	740	1772	1956
	inch	69.33	61.02	86.57	23.35	29.13	69.76	77.01
BS-400HAS/GA	mm	2087	1812	2024	642	777	1890	2207
	inch	82.17	71.34	79.69	25.28	30.59	74.41	86.89
BS-450HAS/GA	mm	2305	2033	2676	704.5	868	2018	2251
	inch	90.75	80.04	105.35	27.74	34.17	79.45	88.62

## 半自動油壓帶鋸機 (手動進料) SEMI-AUTOMATIC HORIZONTAL BANDSAWS (MANUAL BAR FEED)

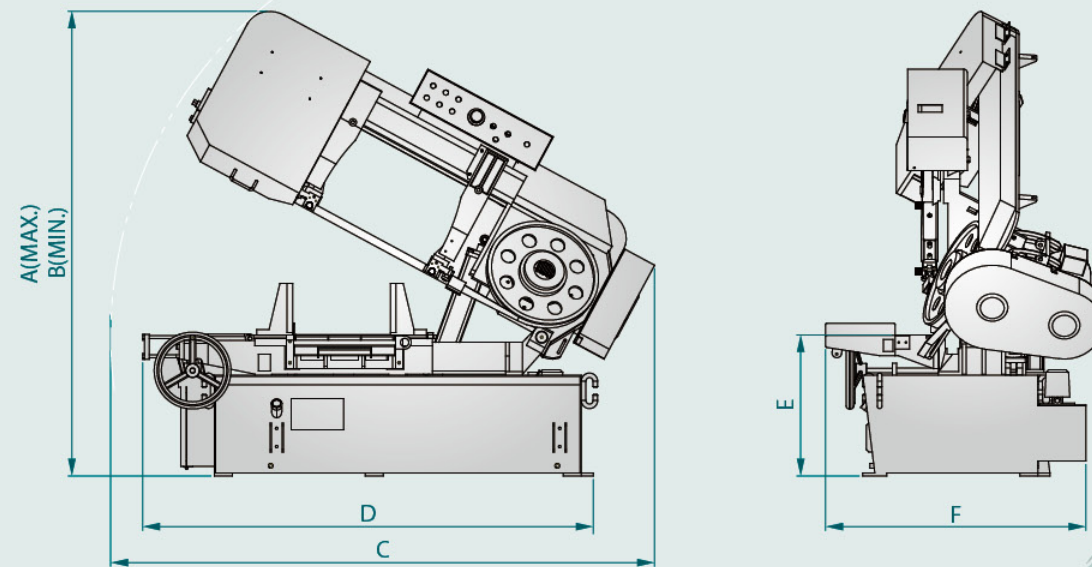

規格 / 機型 SPEC. / MODEL	單位 UNIT	A	B	C	D	E	F
BS-400SA	mm	2030	1700	2085	1320	585	740
	inch	80	67	82	52	23	29
BS-450SA	mm	2285	1805	2390	1600	685	850
	inch	90	71	94	63	27	33
BS-1830	mm	2465	2120	2705	1600	685	850
	inch	97	84	107	63	27	33