



**SPECIALISED FORCE**  
 HYDRAULIC TOOLS & PTY. LTD.  
 ELECTRICAL CONTRACTORS EQUIPMENT

EXCLUSIVE DISTRIBUTOR OF



**INTELLIGENT PNEUMATIC  
 TORQUE WRENCH SOLUTIONS**



**intelliTORQ®**



# GT SERIES PNEUMATIC TORQUE WRENCHES

**SF** **SPECIALISED FORCE**  
HYDRAULIC TOOLS & ELECTRICAL CONTRACTORS EQUIPMENT  
PTY. LTD.



## GT SERIES PNEUMATIC TORQUE WRENCHES

**GT200P55 GT500P55 GT800P55  
GT1300P55 GT2600P55**



**inteliTORQ® FRL UNIT (MADE IN USA)**

## inteliTORQ® FRL

- Most **intelligent FRL solution electronically converts the regulator pressure into torque** based on each tool's digital torque chart stored in the FRL
- **No printed torque charts needed** as all data is digitally stored in the unit
- Precision instrument grade regulator with enhanced pressure recovery allows pressure setting without running the tool motor
- Torque can be displayed in different units: ft-lbs, N-m or Kgf-m
- One inteliTORQ FRL can be used with up to 4 different tools; tool model and serial
- Numbers always displayed along with torque setting
- Tools can be added / removed in seconds; no cables or computer needed
- Can also display line pressure (PSI, Bar, MPa or Atm) and may be used with a printed torque chart
- This system uses an extended life battery, accessible from the top without disassembly

## INTELLIGENT PNEUMATIC TORQUE WRENCH SOLUTIONS



# inteliTORQ®

PNEUMATIC TORQUE WRENCH

[www.specialisedforce.com.au](http://www.specialisedforce.com.au)





## THE TORQ FUSION MODULAR TORQUE DELIVERY SYSTEM

GT series pneumatic torque wrenches are integrated torque delivery solutions designed to be intuitive, ergonomic and reliable. At the heart of our tools are powerful pneumatic multi-vane motors mated to proprietary precision multi stage planetary gearboxes. TORQ Fusion® pays special attention to ergonomics, which is why we created our tools using comfortable elastomer lined, impact resistant composite motor housings combined with various exotic alloy steels and proprietary designs throughout the planetary gearbox for the lowest possible tool weight. This accomplishment is reflected by a multitude of patents.

The GT series feature a modular design allowing the user to quickly change between available output drives, reaction arms, extensions and various custom accessories as needed, making it one of the most versatile torque delivery system on the market.

No two bolting applications are the same and as such we realize that no single FRL design can meet the needs of all of our customers. This prompted us to develop 3 different FRL versions ranging from our cost-effective analog option to our advanced inteliTORQ™ solution.

PNEUMATIC TORQUE WRENCH

www.specialisedforce.com.au

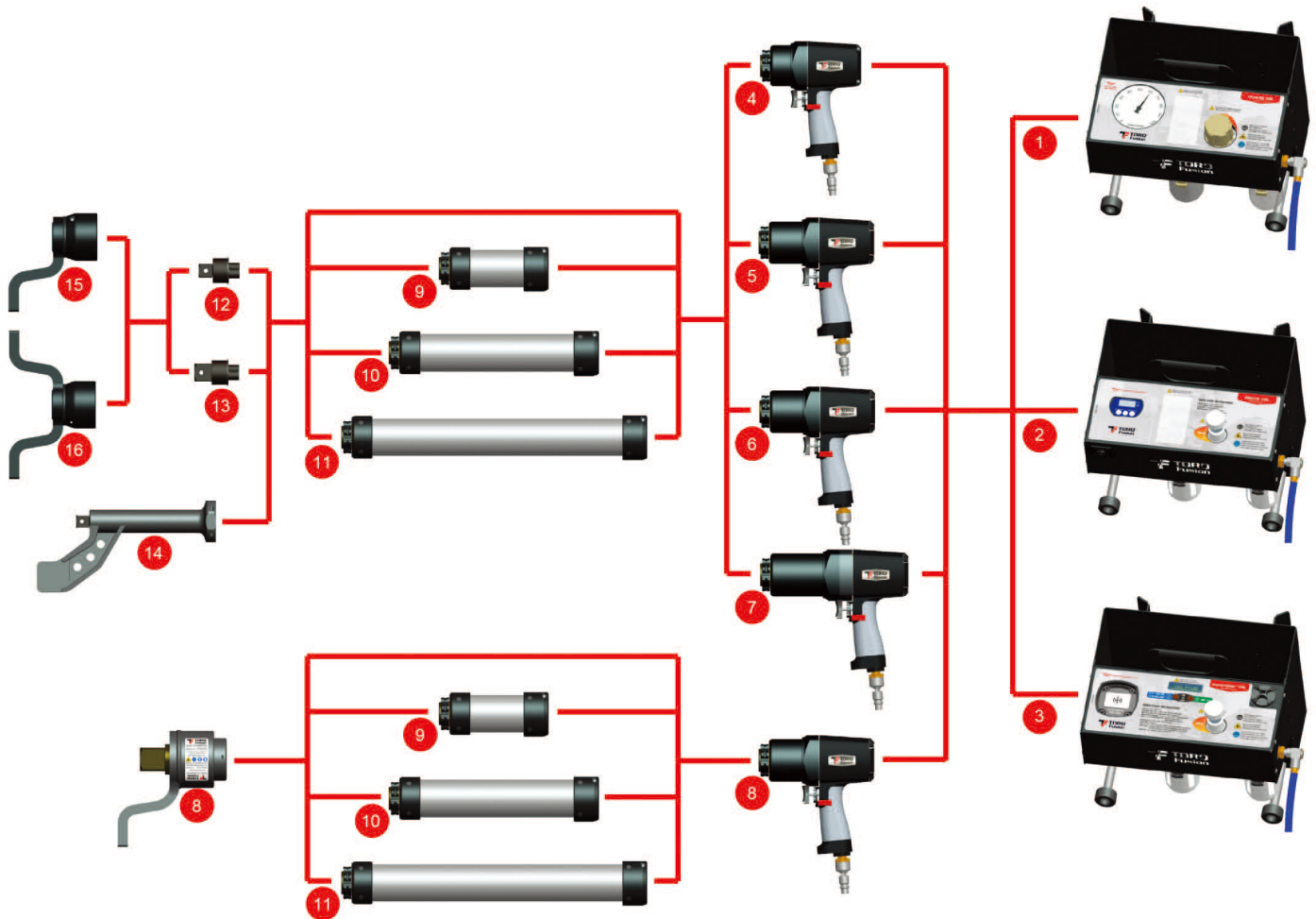

Item	Description
1	ANALOG FRL WITH STANDARD REGULATOR
2	DIGITAL FRL WITH PRECISION REGULATOR
3	inteliTORQ™ FRL WITH DIGITAL DISPLAY CONVERTS PRESSURE INTO TORQUE
4	GT200PSS TORQUE WRENCH, 200 FT-LBS, 66 RPM, 86 dB(A)
5	GT500PSS TORQUE WRENCH, 500 FT-LBS, 17 RPM, 86 dB(A)
6	GT800PSS TORQUE WRENCH, 800 FT-LBS, 12 RPM, 86 dB(A)
7	GT1300PSS TORQUE WRENCH, 1300 FT-LBS, 7.5 RPM, 86 dB(A)
8	GT2600PSS TORQUE WRENCH, 2600 FT-LBS, 3.3 RPM, 86 dB(A)

Item	Description
9	6" EXTENSION
10	12" EXTENSION
11	18" EXTENSION
12	3/4" SQUARE DRIVE
13	1" SQUARE DRIVE
14	WHEEL ATTACHMENT FOR FLEET MAINTENANCE
15	STANDARD REACTION ARM
16	CUSTOM DEVELOPED REACTION ARMS ARE AVAILABLE



**GT200PSS (MADE IN USA)**

**SPECIFICATIONS**

PARAMETER	IMPERIAL	METRIC
Output Drive	3/4" SQ	
Max Torque	200 ft-lbs	271 N-m
Min Torque	35 ft-lbs	47 N-m
Max Speed	65 RPM	
Max Noise <sup>2</sup>	86 dB(A)	
System Accuracy	5%	
Tool Weight	5.4 lbs	2.5 Kg
Reaction Arm Weight	2.9 lbs	1.3 Kg
Output Drive Weight	0.4 lbs	0.2 Kg
6" Tool Extension Weight	4.6 lbs	2.1 Kg
12" Tool Extension Weight	6.9 lbs	3.1 Kg
18" Tool Extension Weight	9.1 lbs	4.1 Kg
FRL Weight	13 lbs	5.9 Kg
Max Inlet Air Pressure <sup>3</sup>	110 psi	7.58 Bar
Max Air Consumption <sup>4</sup>	20 CFM	566 l/min
Air Connection	1/4" NPT	
FRL Battery	9V (PP3)	
FRL Accuracy	<1%	
Warranty	1 year limited	

- 3/4" square drive is standard on all tools. Other drive types may be custom developed.
- Maximum noise level at 100 PSI without a load; noise levels under load are lower.
- Never set FRL to a pressure higher than indicated on the torque chart.
- To achieve maximum operating range of the tool air supply must be at least 20 CFM @ 115psi.

**GENERAL FEATURES:**

- 200 ft-lbs max torque
- modular design, shares accessories with all other models
- 56 max RPM
- weighs 8.7 lbs or 4 kg
- field replaceable square drive
- 6 vane extended life motor
- made in USA



**DIMENSIONS (mm)**

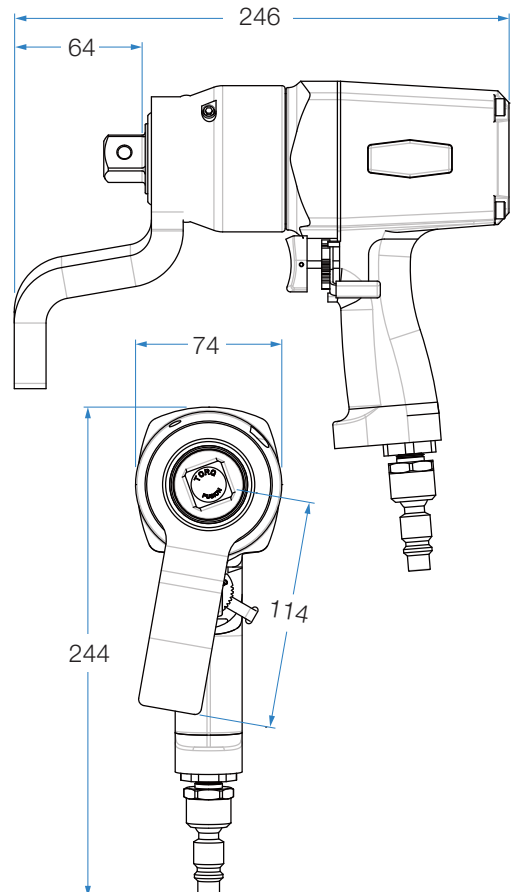

**PERFORMANCE**

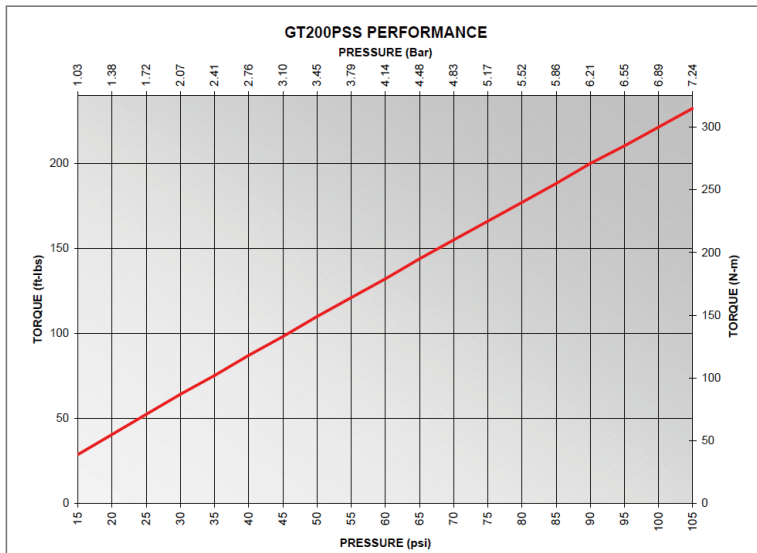

**PNEUMATIC TORQUE WRENCH**

**www.specialisedforce.com.au**

## GT500PSS (MADE IN USA)

### SPECIFICATIONS

PARAMETER	IMPERIAL	METRIC
Output Drive	3/4" SQ	
Max Torque	500 ft-lbs	678 N-m
Min Torque	100 ft-lbs	136 N-m
Max Speed	17 RPM	
Max Noise <sup>2</sup>	86 dB(A)	
System Accuracy	5%	
Tool Weight	6.4 lbs	2.9 Kg
Reaction Arm Weight	2.9 lbs	1.3 Kg
Output Drive Weight	0.4 lbs	0.2 Kg
6" Tool Extension Weight	4.6 lbs	2.1 Kg
GT500PSS Total Weight	9.7 lbs	4.4 Kg
GT500PSS-Whl Ed Weight	14.3 lbs	6.5 Kg
FRL Weight	13 lbs	5.9 Kg
Max Inlet Air Pressure <sup>3</sup>	110 psi	7.58 Bar
Max Air Consumption <sup>4</sup>	20 CFM	566 l/min
Air Connection	1/4" NPT	
FRL Battery	9V (PP3)	
FRL Accuracy	<1%	
Warranty	1 year limited	

- 3/4" square drive is standard on all tools. Other drive types may be custom developed.
- Maximum noise level at 100 PSI without a load; noise levels under load are lower.
- Never set FRL to a pressure higher than indicated on the torque chart.
- To achieve maximum operating range of the tool air supply must be at least 20 CFM @ 115psi.

### PERFORMANCE

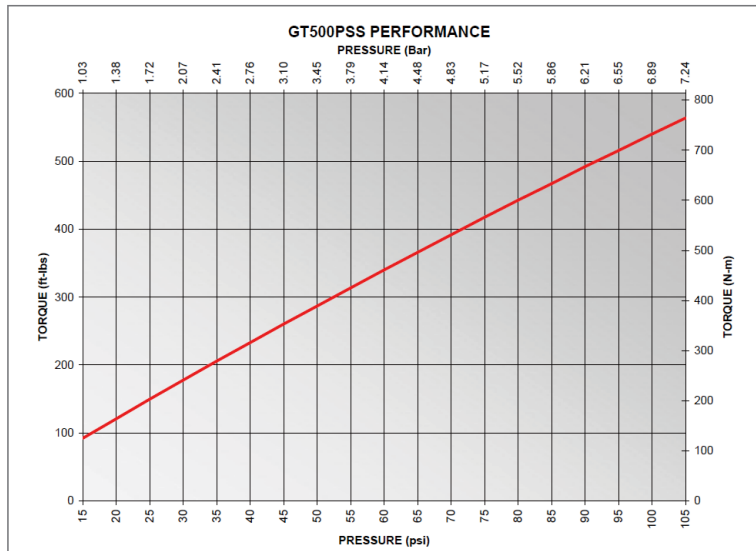

### GENERAL FEATURES:

- 500 ft-lbs max torque
- modular design, shares accessories with all other models
- 17 max RPM
- weighs 9.7 lbs or 4.4 kg
- field replaceable square drive
- 6 vane extended life motor
- made in USA



### DIMENSIONS (mm)

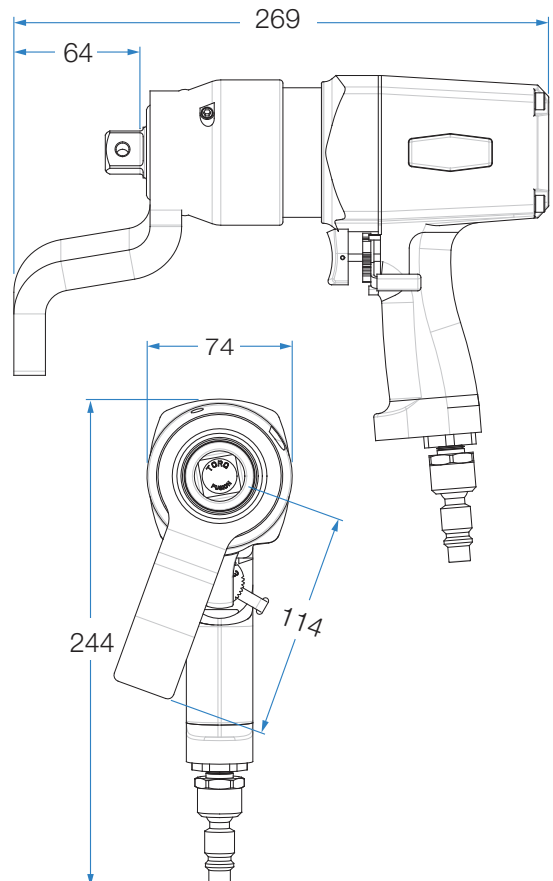





**GT800PSS (MADE IN USA)**

**SPECIFICATIONS**

PARAMETER	IMPERIAL	METRIC
Output Drive	3/4" SQ	
Max Torque	800 ft-lbs	1,085 N-m
Min Torque	150 ft-lbs	203 N-m
Max Speed	12 RPM	
Max Noise <sup>2</sup>	86 dB(A)	
System Accuracy	5%	
Tool Weight	6.4 lbs	2.9 Kg
Reaction Arm Weight	2.9 lbs	1.3 Kg
Output Drive Weight	0.4 lbs	0.2 Kg
6" Tool Extension Weight	4.6 lbs	2.1 Kg
12" Tool Extension Weight	6.9 lbs	3.1 Kg
18" Tool Extension Weight	9.1 lbs	4.1 Kg
FRL Weight	13 lbs	5.9 Kg
Max Inlet Air Pressure <sup>3</sup>	115 psi	7.58 Bar
Max Air Consumption <sup>4</sup>	20 CFM	566 l/min
Air Connection	1/4" NPT	
FRL Battery	9V (PP3)	
FRL Accuracy	<1%	
Warranty	1 year limited	

1. 3/4" square drive is standard on all tools. 1" square drive may also be supplied upon request. Other drive types may be custom developed.  
 2. Maximum noise level at 100 PSI without a load; noise levels under load are lower.  
 3. Never set FRL to a pressure higher than indicated on the torque chart.  
 4. To achieve maximum operating range of the tool air supply must be at least 20 CFM @ 115psi.

**PERFORMANCE**

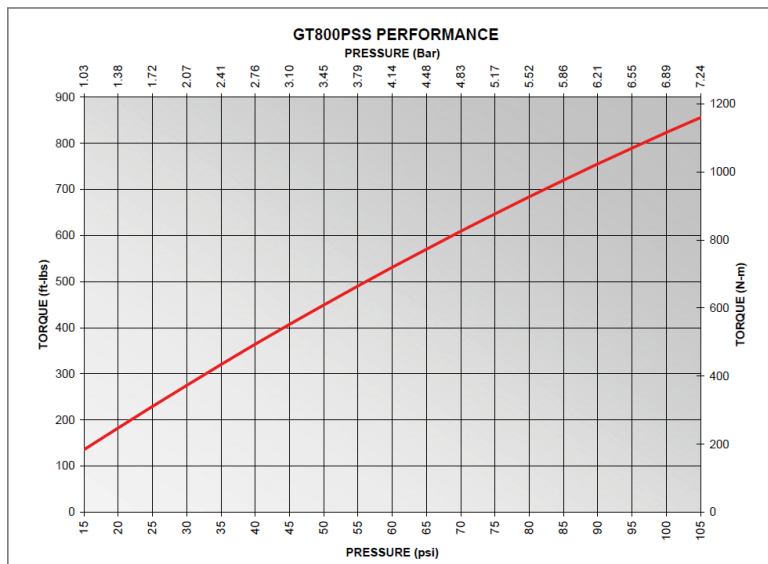

**GENERAL FEATURES:**

- 800 ft-lbs max torque
- modular design, shares accessories with all other models
- 12 max RPM
- weighs 9.7 lbs or 4.4 kg
- field replaceable square drive
- 6 vane extended life motor
- made in USA



**DIMENSIONS (mm)**

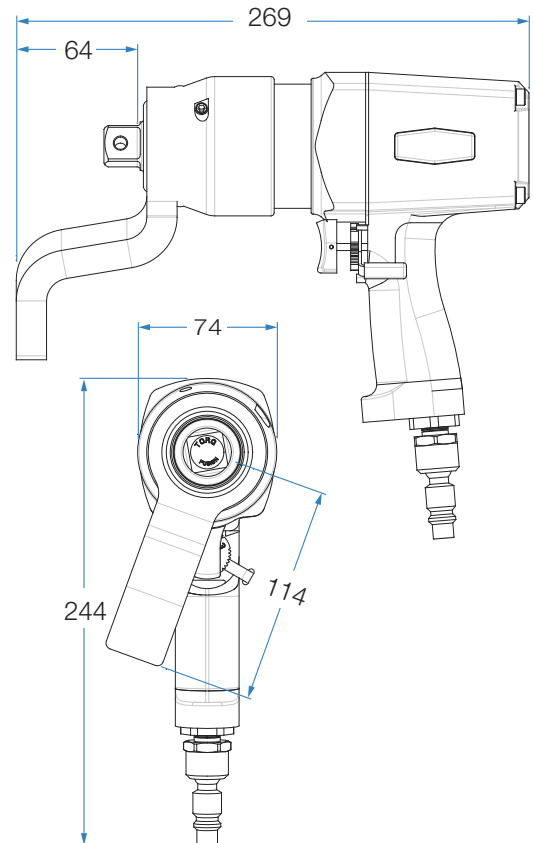

**PNEUMATIC TORQUE WRENCH**

**www.specialisedforce.com.au**

## GT1300PSS (MADE IN USA)

### SPECIFICATIONS

PARAMETER	IMPERIAL	METRIC
Output Drive	1" SQ	
Max Torque	1300 ft-lbs	1,763 N-m
Min Torque	200 ft-lbs	271 N-m
Max Speed	7.5 RPM	
Max Noise <sup>2</sup>	86 dB(A)	
System Accuracy	5%	
Tool Weight	8.6 lbs	3.9 Kg
Reaction Arm Weight	2.9 lbs	1.3 Kg
Output Drive Weight	0.4 lbs	0.2 Kg
6" Tool Extension Weight	4.6 lbs	2.1 Kg
12" Tool Extension Weight	6.9 lbs	3.1 Kg
18" Tool Extension Weight	9.1 lbs	4.1 Kg
FRL Weight	13 lbs	5.9 Kg
Max Inlet Air Pressure <sup>3</sup>	110 psi	7.58 Bar
Max Air Consumption <sup>4</sup>	20 CFM	566 l/min
Air Connection	1/4" NPT	
FRL Battery	9V (PP3)	
FRL Accuracy	<1%	
Warranty	1 year limited	

### GENERAL FEATURES:

- 1,300 ft-lbs max torque
- modular design, shares accessories with all other models
- 7.5 max RPM
- weighs 11.9 lbs or 5.4 kg
- field replaceable square drive
- 6 vane extended life motor
- made in USA



1. 1" square drive is standard on all tools. 3/4" square drive may also be supplied upon request. Other drive types may be custom developed.
2. Maximum noise level at 100 PSI without a load; noise levels under load are lower.
3. Never set FRL to a pressure higher than indicated on the torque chart.
4. To achieve maximum operating range of the tool air supply must be at least 20 CFM @ 115psi.

### PERFORMANCE

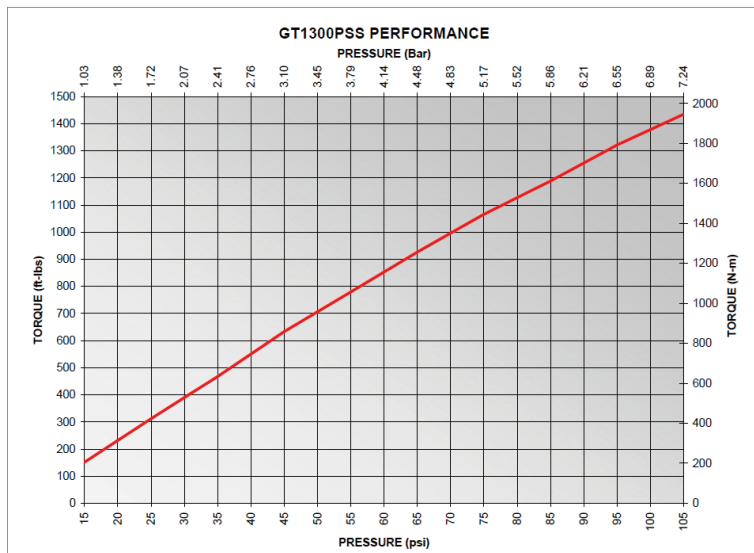

### DIMENSIONS (mm)

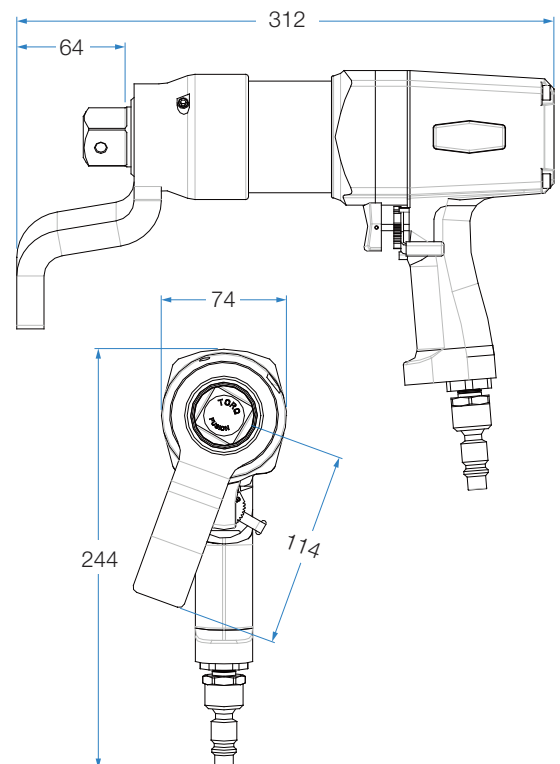





**GT2600PSS (MADE IN USA)**

**SPECIFICATIONS**

PARAMETER	2600 MODE		800 MODE <sup>1</sup>	
	IMPERIAL	METRIC	IMPERIAL	METRIC
Output Drive	1" or 1-1/2" SQ		3/4 or 1" SQ	
Max Torque	2600 ft-lbs	3,525 N-m	800 ft-lbs	1,085 N-m
Min Torque	550 ft-lbs	746 N-m	150 ft-lbs	203 N-m
Max Speed	3.3 RPM		12 RPM	
Max Noise <sup>2</sup>	86 dB(A)			
System Accuracy	5%			
Tool Weight	16.7 lbs	7.6 Kg	6.4 lbs	2.9 Kg
Reaction Arm Weight	Included in tool weight		2.9 lbs	1.3 Kg
Output Drive Weight	Included in tool weight		0.4 lbs	0.2 Kg
6" Tool Extension Weight	4.6 lbs	2.1 Kg	4.6 lbs	2.1 Kg
12" Tool Extension Weight	6.9 lbs	3.1 Kg	6.9 lbs	3.1 Kg
18" Tool Extension Weight	9.1 lbs	4.1 Kg	9.1 lbs	4.1 Kg
FRL Weight	13 lbs	5.9 Kg	13 lbs	5.9 Kg
Max Inlet Air Pressure <sup>3</sup>	110 psi	7.58 Bar	110 psi	7.58 Bar
Max Air Consumption <sup>4</sup>	20 CFM	566 l/min	20 CFM	566 l/min
Air Connection	1/2" NPT			
FRL Battery	9V (PP3)			
FRL Accuracy	<1%			
Warranty	1 year limited			

**GENERAL FEATURES:**

- 2,600 ft-lbs max torque
- modular design, shares accessories with all other models
- 3.3 max RPM
- weighs 16.7 lbs or 7.6 kg
- also includes a GT800PSS tool
- 6 vane extended life motor
- made in USA



1. 800 mode may require additional accessories such as a standard reaction arm and square drive.
2. Maximum noise level at 100 PSI without a load; noise levels under load are lower.
3. Never set FRL to a pressure higher than indicated on the torque chart.
4. To achieve maximum operating range of the tool air supply must be at least 20 CFM @ 115psi.

**PERFORMANCE**

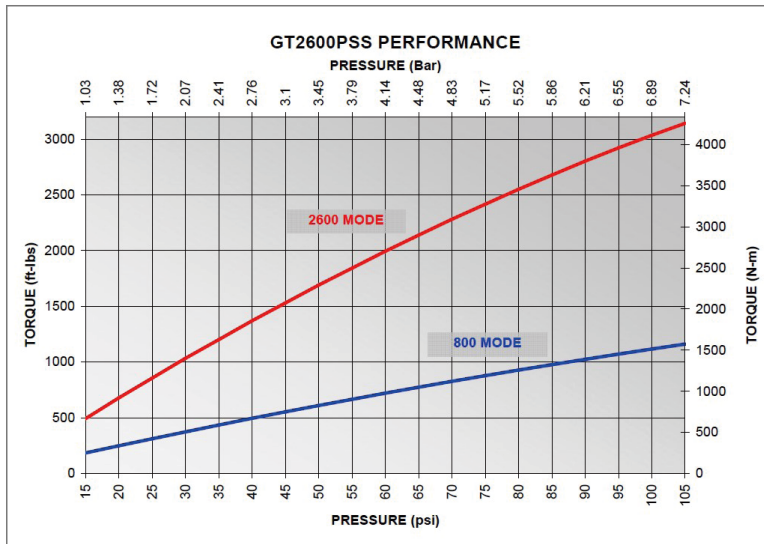

**DIMENSIONS (mm)**

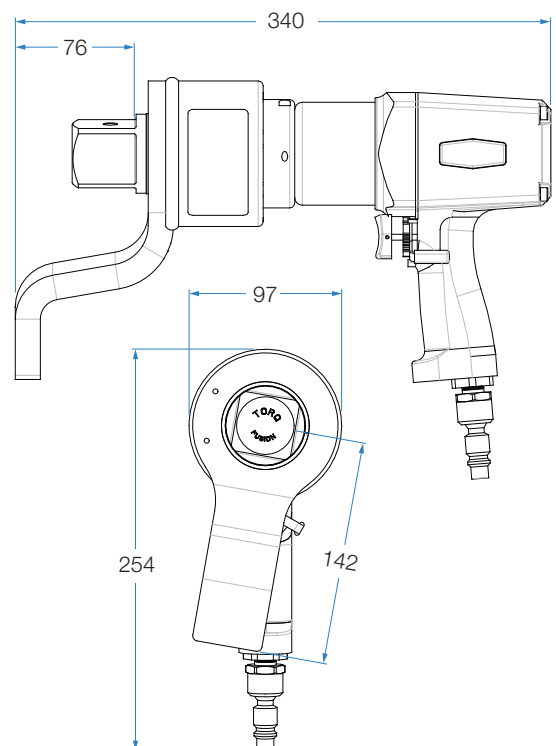

**PNEUMATIC TORQUE WRENCH**

**www.specialisedforce.com.au**

## OTHER FRL OPTIONS

### GENERAL FEATURES:

Pneumatic torque wrenches are only as accurate as the air pressure level supplied to them which is why we put significant effort in creating our FRLs using only top brand components. To meet the needs of all of our customers, we offer our pneumatic torque wrenches with 3 different FRL options. Some of the common features are:

- 1/2" SMC® brand pneumatic components; rubber feet and handle grip
- 12 ft (3.7 m) pneumatic hose with swivel and quick disconnect at tool and swivel at FRL
- Quick Start Instructions and safety precautions for operating the tool printed on top surface
- Durable 16 ga (1.5 mm) steel construction with powder coated finish, weighted for stability while using tool
- Integrated storage compartment for tool, several sockets and other accessories as well as hose storage
- Measures 14" W x 14" H x 14.5" D (35.6 cm W x 35.6 cm H x 36.8 cm D)

### Analog FRL

- Most cost effective option
- Features a large 4" analog gauge for ease of reading and precision adjustment
- The torque chart is attached to the top surface of the unit so it cannot be lost
- Torque chart values given every 5 PSI (0.35 Bar) for increased precision
- Like most FRLs, the tool must be running while adjusting the pressure
- Clear polycarbonate filter and lubricator bowl protectors



### Digital FRL

- This FRL further reduces the possibility of errors by introducing a digital display
- Precision instrument grade regulator with enhanced pressure recovery allows pressure setting without running the tool motor
- LCD gauge displays pressure with decimal point accuracy, further eliminating errors when reading pressure
- Displays air pressure in PSI, Bar or MPa
- The torque chart is attached to the top surface of the unit so it cannot be lost
- Torque chart values given every 5 PSI (0.35 Bar) for increased precision
- This system uses an extended life battery, accessible from the front without disassembly

