



**ItalianGelato**  
Concepts  
*dessert projects & equipment supply*

# turbomix

Emulsifier for making

**Artisanal  
Gelato mixes**



**cattabriga**



# cattabriga



## Vertical Span

To emulsify a large amount of mixture, Turbomix has a vertical span of almost 40 cm.



## Horizontal Range

To suck in the solid ingredients that tend to stick to the sides of the bucket, the Turbomix can be moved in a circular movement.



## Command Panel

Includes all the Turbomix functions. When pressed, an emergency switch makes it possible to immediately stop the machine.



## Changing Mixers

Unscrewing the ring under the motor, the mixer attachment unlocks and can be changed.

Cattabriga Turbomix is an essential tool in the modern gelato production area for making all mixes. It blends, emulsifies, and pulverized dry, fibrous, and fat ingredients into liquids, producing perfectly uniform gelato mixes. Besides being useful for artisanal gelato mixes, it is also helpful for emulsifying dense products in the pastry shop.



### **Cream Mixer (1)**

The high rotation speed and motor shape quickly emulsify pastes, bringing out aroma and creaminess.



### **Fruit Mixer (2)**

Perfect for chopping up and blending fresh and frozen fruit.



### **Optional Cutter (3)**

A mixer for chopping up big pieces of fruit, even dense ones, like pears and apples.

### **Emulsion Times**

To emulsify flavouring pastes in base mixes, about 30 seconds for 5 litres.  
To produce a complete mix, starting from single ingredients, about 2 minutes to make 5 litres of perfectly emulsified mixture.

# turbomix

## TECHNICAL SPECIFICATIONS

**turbomix**

RPM	3.000 - 12.000
Minimum quantity per cycle	3 lt*
Maximum quantity per cycle	15 lt
Electrical specifications	200 - 240 volt 50 - 60 Hz 0,75 kW
Weight	65 kg

\* even less with a suitable container.

All specifications mentioned must be considered approximate. Iceteam 1927 reserves the right to modify, without notice, all parts deemed necessary.

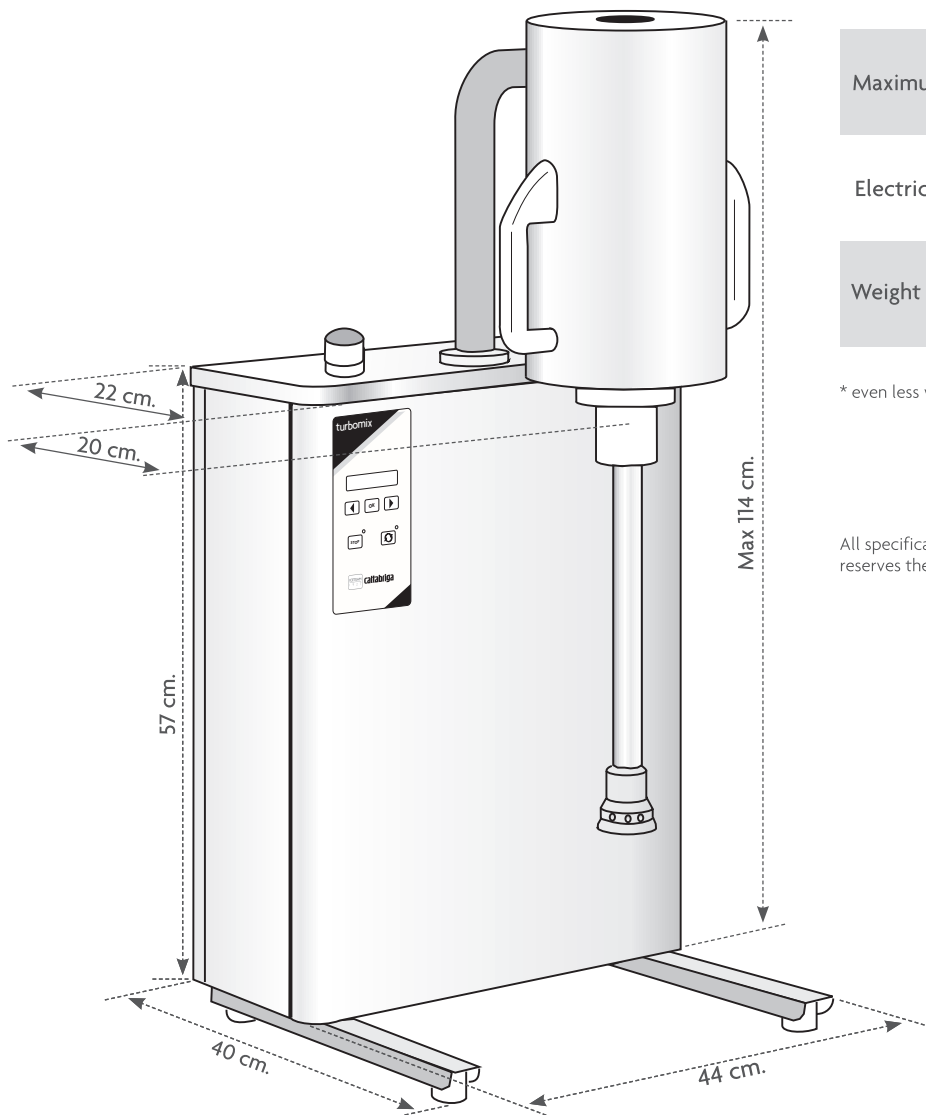

Italian Gelato Concepts Pty Limited  
Unit 1, 37 Mortimer Road  
Acacia Ridge Qld 4110

Bris Office: +61 (0) 7 3162 7724  
Syd Office +61 (0) 2 8311 9701

Email: [info@italiangelato.com.au](mailto:info@italiangelato.com.au)

[www.italiangelato.com.au](http://www.italiangelato.com.au)



ICETEAM 1927 - ALI Group Srl

Via Emilia, 45/A  
40011 Anzola dell'Emilia - Italy  
Phone +39.051.6505.330  
Fax +39.051.6505.331

an Ali Group Company



The Spirit of Excellence