

SELF-CONTAINED

JM12-2

SELF CONTAINED ISLAND MERCHANDISER

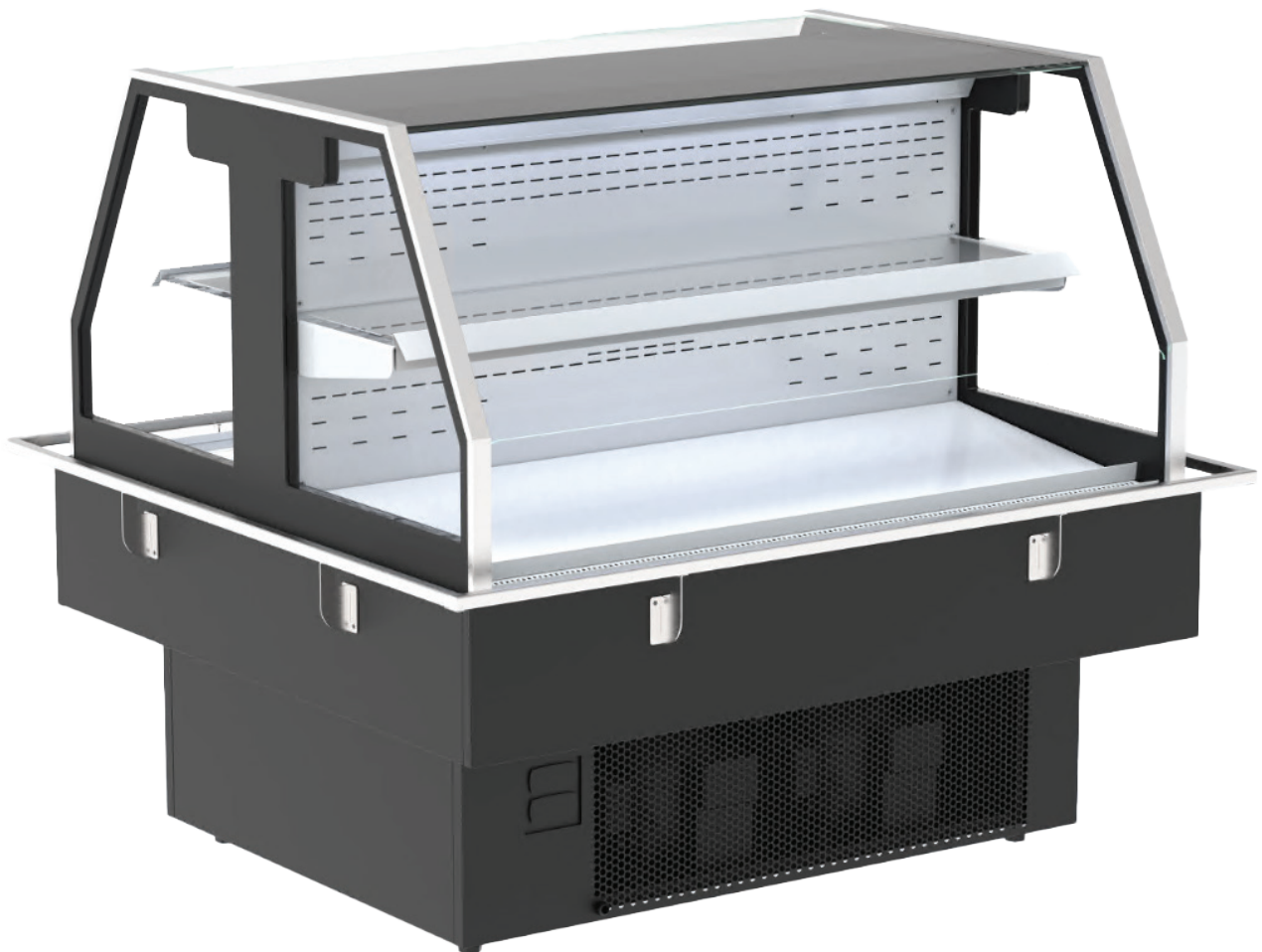

ENHANCED ENERGY EFFICIENCY
& VERSATILITY

HUSSmann[®]

NOTE: Shown with timber panels as optional feature



PRODUCT BENEFITS

- Ergonomic design for easy access
- Optimised display with LED lighting
- Longer merchandise shelf life
- Product temperature compliance
- Simple to install and maintain
- Suitable for Drinks, Specialty, Bakery and Grab and Go Merchandising

STANDARD FEATURES

- Internal panels - polished stainless steel
- External panels - powder coated steel
- Single row canopy light - 4000K
- Single row shelf light - 4000K
- Single row glass shelf - 270mm
- Angled base deck - 440mm
- Internal base liner - Stainless Steel
- Ticket strips
- EC fans
- Digital controller fitted

CUSTOMISATIONS

ENDS

- Included

BUMPER

- Stainless steel bumper
- Timber cladding (option shown on front page)

OTHER

- Technology solutions
- Electronic shelf labels

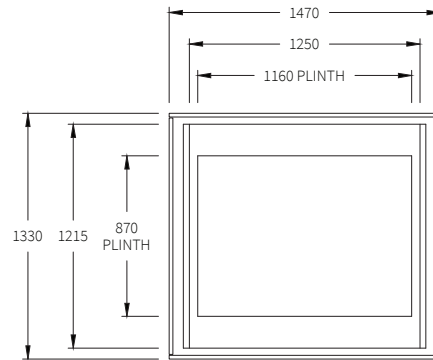
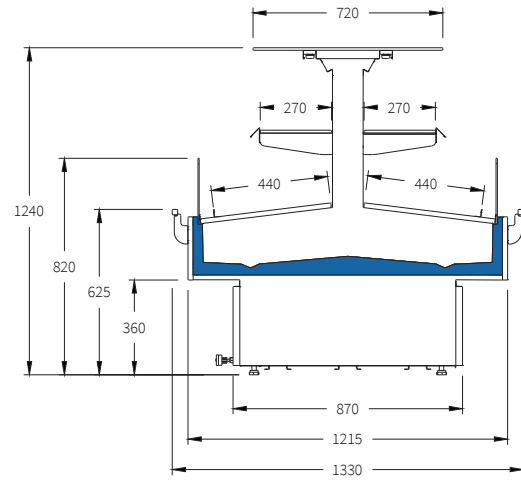

TECHNICAL DATA	
Model (JM12-2)	JM12-2
Depth (mm)	1330
Width (mm)	1470
Height (mm)	1240
Refrigerant Type	R290
Refrigerant Charge	2 x 150-grams
Total Display Area TDA (m ²)	1.94

AVAILABLE COLOURS



TEMPERATURE CLASS

3M2

(-1°C to +7°C)

Additional Information

All Dimensions shown in Millimetres (mm) unless otherwise stated. Dimensions and features are subject to change. Please obtain current technical information prior to order confirmation.

NOTE: We reserve the right to change or revise specifications and product design in connection with any feature of our products. Such changes do not entitle the buyer to corresponding changes, improvements, additions or replacements for equipment previously sold or Shipped.