

The Olympus Treatment Bed - Black

Item Code: TBoo3B

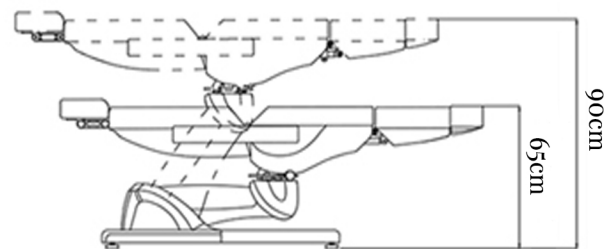

UPHOLSTERY

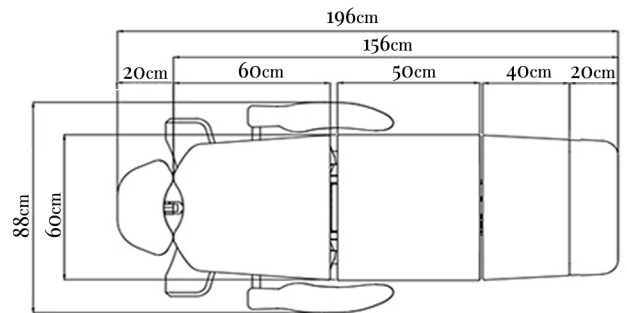

Medical grade antimicrobial vinyl

FOAM



Quick recovery memory foam

MOTORS



Highly durable linear actuators (4 motors)

KEY FEATURES



Smart active remote with 3 motors adjusts back, leg and height, face hole with insert pillow, removable/adjustable armrests

WEIGHT CAPACITY

KG 250 Kgs

PACKING DIMENSIONS

 130 X 80 X 77cm

VOLUME

 0.80m³

WARRANTY

 Structure - 5 Years
Vinyl - 2 Years
Motors - 2 Years