



CW Series - Gas Wok

Models:

CW1H-C

CW2H-CC

CW3H-CCC

CW1H-D

CW2H-CD

CW3H-CCD

CW2H-DD

CW3H-CDD

CW3H-DDD

INSTALLATION AND OPERATION MANUAL

MANUFACTURED BY

Moffat Limited
Rolleston 7675
New Zealand

INTERNATIONAL CONTACTS

AUSTRALIA

Moffat Pty Limited
E.Mail: vsales@moffat.com.au
Main Office: (tel): +61 (03) 9518 3888
(fax): +61 (03) 9518 3833
Service: (tel): 1800 622 216
Spares: (tel): 1800 337 963
Customer Service: (tel): 1800 335 315
(fax): 1800 350 281

CANADA

Serve Canada
Web: www.servecanada.com
E.Mail: info@servecanada.com
Sales: (tel): 800 551 8795 (Toll Free)
Service: (tel): 800 263 1455 (Toll Free)

NEW ZEALAND

Moffat Limited
Web: www.moffat.co.nz
E.Mail: sales@moffat.co.nz
Main Office: (tel): 0800 663328

UNITED KINGDOM

Blue Seal
Web: www.blue-seal.co.uk
E.Mail: sales@blue-seal.co.uk
Sales: (tel): +44 121 327 5575
(fax): +44 121 327 9711
Spares: (tel): +44 121 322 6640
(fax): +44 121 327 9201
Service: (tel): +44 121 322 6644
(fax): +44 121 327 6257

UNITED STATES

Moffat
Web: www.moffat.com
Sales: (tel): 1800 551 8795 (Toll Free)
(tel): +1 336 661 1556
(fax): +1 336 661 9546
Service: (tel): 866 673 7937 (Toll Free)
(tel): +1 366 661 1556
(fax): +1 336 661 1660

REST OF WORLD

Moffat Limited
Web: www.moffat.co.nz
E.Mail: export@moffat.co.nz

The reproduction or copying of any part of this manual by any means whatsoever is strictly forbidden unless authorized previously in writing by the manufacturer.

In line with policy to continually develop and improve its products, Moffat Ltd. reserves the right to change the specifications and design without prior notice.

© Copyright Moffat Ltd. October 2017.

CW Series - Gas Wok.

Introduction	2
Specifications	3
Models Covered in this Specification	
General	
Assembly	
Gas Connection	
Water Supply Requirements	
Water Drainage	
Gas Supply Requirements	
Dimensions	
Installation	9
Installation Requirements	
Unpacking	
Location	
Clearances	
Gas Connection	
Water Connection	
Drainage Connection	
Commissioning	
Operation.....	12
Operation Guide	
Description of Controls	
Using the Telescopic Water Filling Arm	
Lighting the Pilot Burner	
Lighting the Main Burner	
Turning 'OFF' the Main Burner	
Turning 'OFF' the Pilot Burner	
Cleaning and Maintenance	14
General	
Daily Cleaning	
Weekly Cleaning	
Periodic Maintenance	
Fault Finding	16
Gas Conversion and Specifications	17
Gas Conversion Procedure	
Gas Specifications	
Replacement Parts List	20

Introduction

We are confident that you will be delighted with your COBRA Gas Wok and it will become a most valued appliance in your commercial kitchen.

To ensure you receive the utmost benefit from your new COBRA appliance, there are two important things you can do.

Firstly:

Please read the instruction book carefully and follow directions given. The time taken will be well spent.

Secondly:

If you are unsure of any aspect of the installation, instructions or performance of your appliance, contact your COBRA dealer promptly. In many cases a phone call could answer your question.

WARNING:

IMPROPER INSTALLATION, ADJUSTMENT, ALTERATION, SERVICE OR MAINTENANCE CAN CAUSE PROPERTY DAMAGE, INJURY OR DEATH. READ THE INSTALLATION, OPERATING AND MAINTENANCE INSTRUCTIONS THOROUGHLY BEFORE INSTALLING OR SERVICING THIS APPLIANCE.

WARNING:

INSTRUCTIONS TO BE FOLLOWED IN THE EVENT THE USER SMELLS GAS ARE TO BE POSTED IN A PROMINENT LOCATION. THIS INFORMATION SHALL BE OBTAINED BY CONSULTING THE LOCAL GAS SUPPLIER.

WARNING:

GREAT CARE MUST BE TAKEN BY THE OPERATOR TO USE THE EQUIPMENT SAFELY TO GUARD IT AGAINST RISK OF FIRE.

- **TO MINIMISE THE RISK OF FIRE, THE APPLIANCE MUST NOT BE LEFT 'ON', UNATTENDED.**
- **IT IS RECOMMENDED THAT A REGULAR INSPECTION IS MADE BY A COMPETENT SERVICEMAN TO ENSURE CORRECT AND SAFE OPERATION OF YOUR APPLIANCE IS MAINTAINED.**
- **DO NOT STORE OR USE GASOLINE OR OTHER FLAMMABLE VAPOURS OR LIQUIDS IN THE VICINITY OF THIS OR ANY OTHER APPLIANCE.**
- **DO NOT SPRAY AEROSOLS IN THE VICINITY OF THIS APPLIANCE WHILE IT IS IN OPERATION.**

CAUTION:

This appliance is;

- **For professional use and is to be used by qualified persons only.**
- **Only qualified service persons are to carry out installation, servicing and gas conversion operations.**
- **Components having adjustments protected (e.g. paint sealed) by the manufacturer should not be adjusted by the user / operator.**
- **DO NOT operate the appliance without the supplied legs being fitted.**

Models Covered in this Specification -

CW[1]H-[2] GAS Wok.

- [1] - Number of holes (1, 2 or 3).
- [2] - Each Hole Burner Type (from left),
 - C - Chimney Burner.
 - D - Duckbill Burner.

Standard Models:-

CW1H-C - 1 Hole - 1 Chimney Burner.

CW1H-D - 1 Hole - 1 Duckbill Burner.

CW2H-CC - 2 Hole - 2 Chimney Burners.

CW2H-CD - 2 Hole - 1 Chimney Burner, 1 Duckbill Burner.

CW2H-DD - 2 Hole - 2 Duckbill Burners.

CW3H-CCC - 3 Hole - 3 Chimney Burners.

CW3H-CCD - 3 Hole - 2 Chimney Burners, 1 Duckbill Burner.

CW3H-CDD - 3 Hole - 1 Chimney Burner, 2 Duckbill Burners.

CW3H-DDD - 3 Hole - 3 Duckbill Burners.

The Gas Wok is available as a 1,2 or 3 hole size, each hole having a completely separate gas system module, including the gas connection. Each module can be fitted with either a Duckbill or a Chimney type burner.

General

A commercial heavy duty, gas fired, high performance Wok designed for Asian style commercial cooking, using LPG (Propane) or Natural Gas.

The Wok is available in 3 variants, each of which can be fitted with either a Chimney or Duckbill style burner.

Assembly

This model is delivered completely assembled. Ensure that the adjustable feet are securely attached.

NOTE:

- **This appliance is fitted with adjustable feet to enable the appliance to be positioned securely and level. This should be carried out on completion of the gas connection. Refer to the 'Gas Connection' information overleaf and in the 'Installation Section'.**

Gas Connection

Each Wok hole has its own individual gas supply connection point which is controlled by its own individual regulator supplied with the unit. Refer to the Specification Drawings for gas inlet positions for the various Wok options.

Gas Connection is 3/4" BSP male.

Water Supply Requirements

A cold water supply can be connected to water inlet connection (R 1/2" BSP - Female Flare Fitting), refer to Specification Drawings for water inlet positions for the various options.

Water connection should be plumbed in accordance with National / Local Codes covering installation.

Maximum Water Supply Pressure 550 kPa (80psi).

Water Drainage

A water drainage point is located 70mm from the LH side of the appliance and 200mm down from the bench top.

A (R 1 1/2" BSP) Male outlet is provided for connection of a drainage connection to a suitable drainage point.

Specifications

Gas Supply Requirements

- Australia:

	Burner Type	Natural Gas	LPG (Propane)
Burner Ratings	- C (Chimney Burner)	95 MJ/hr	95 MJ/hr
	- D (Duckbill Burner)	105 MJ/hr	105 MJ/hr
	Model	Natural Gas	LPG (Propane)
Model Ratings Total Nominal Hourly Gas Consumption	CW1H-C	95 MJ/hr	95 MJ/hr
	CW1H-D	105 MJ/hr	105 MJ/hr
	CW2H-CC	190 MJ/hr	190 MJ/hr
	CW2H-CD	200 MJ/hr	200 MJ/hr
	CW2H-DD	210 MJ/hr	210 MJ/hr
	CW3H-CCC	285 MJ/hr	285 MJ/hr
	CW3H-CCD	295 MJ/hr	295 MJ/hr
	CW3H-CDD	305 MJ/hr	305 MJ/hr
	CW3H-DDD	315 MJ/hr	315 MJ/hr
Supply Pressure		1.13 - 3.40 kPa	2.75 - 4.50 kPa
Burner Operating Pressure (*)		1.0 kPa	2.65 kPa
Gas Connection		¾" BSP Male	

- New Zealand:

	Burner Type	Natural Gas	LP Gas
Burner Ratings	- C (Chimney Burner)	95 MJ/hr	N/A
	- D (Duckbill Burner)	105 MJ/hr	85 MJ/hr
	Model	Natural Gas	LP Gas
Model Ratings Total Nominal Hourly Gas Consumption	CW1H-C	95 MJ/hr	N/A
	CW1H-D	105 MJ/hr	85 MJ/hr
	CW2H-CC	190 MJ/hr	N/A
	CW2H-CD	200 MJ/hr	N/A
	CW2H-DD	210 MJ/hr	170 MJ/hr
	CW3H-CCC	285 MJ/hr	N/A
	CW3H-CCD	295 MJ/hr	N/A
	CW3H-CDD	305 MJ/hr	N/A
	CW3H-DDD	315 MJ/hr	255 MJ/hr
Supply Pressure		1.13 - 3.40 kPa	2.75 - 4.50 kPa
Burner Operating Pressure (*)		1.0 kPa	2.65 kPa
Gas Connection		¾" BSP Male	

NOTE:

- (*) Burner operating pressure is to be measured at Pressure Test Point on each individual gas regulator, with the burner operating at 'High Flame' setting.
- Operating pressure is ex-factory set and is not to be adjusted, apart from when converting between gases, if required.
- Refer to 'Gas Conversion and Specifications' section in this manual for further details.

- All Other Markets:

	Burner Type	Natural Gas	LPG (Propane)	Butane
Burner Ratings	- C (Chimney Burner)	95 MJ/hr	95 MJ/hr	N/A
	- D (Duckbill Burner)	105 MJ/hr	105 MJ/hr	105 MJ/hr
	Model	Natural Gas	LPG (Propane)	Butane
Total Nominal Hourly Gas Consumption	CW1H-C	95 MJ/hr	95 MJ/hr	N/A
	CW1H-D	105 MJ/hr	105 MJ/hr	105 MJ/hr
	CW2H-CC	190 MJ/hr	190 MJ/hr	N/A
	CW2H-CD	200 MJ/hr	200 MJ/hr	N/A
	CW2H-DD	210 MJ/hr	210 MJ/hr	210 MJ/hr
	CW3H-CCC	285 MJ/hr	285 MJ/hr	N/A
	CW3H-CCD	295 MJ/hr	295 MJ/hr	N/A
	CW3H-CDD	305 MJ/hr	305 MJ/hr	N/A
	CW3H-DDD	315 MJ/hr	315 MJ/hr	315 MJ/hr
Supply Pressure		1.13 - 3.40 kPa	2.75 - 4.50 kPa	
Burner Operating Pressure (*)		1.0 kPa	2.65 kPa	
Gas Connection		$\frac{3}{4}$ " BSP Male		

NOTE:

- (*) Burner operating pressure is to be measured at Pressure Test Point on each individual gas regulator, with the burner operating at 'High Flame' setting.
- Operating pressure is ex-factory set and is not to be adjusted, apart from when converting between gases, if required.
- Refer to 'Gas Conversion and Specifications' section in this manual for further details.

Specifications

Dimensions

Cobra Single Hole Wok Model

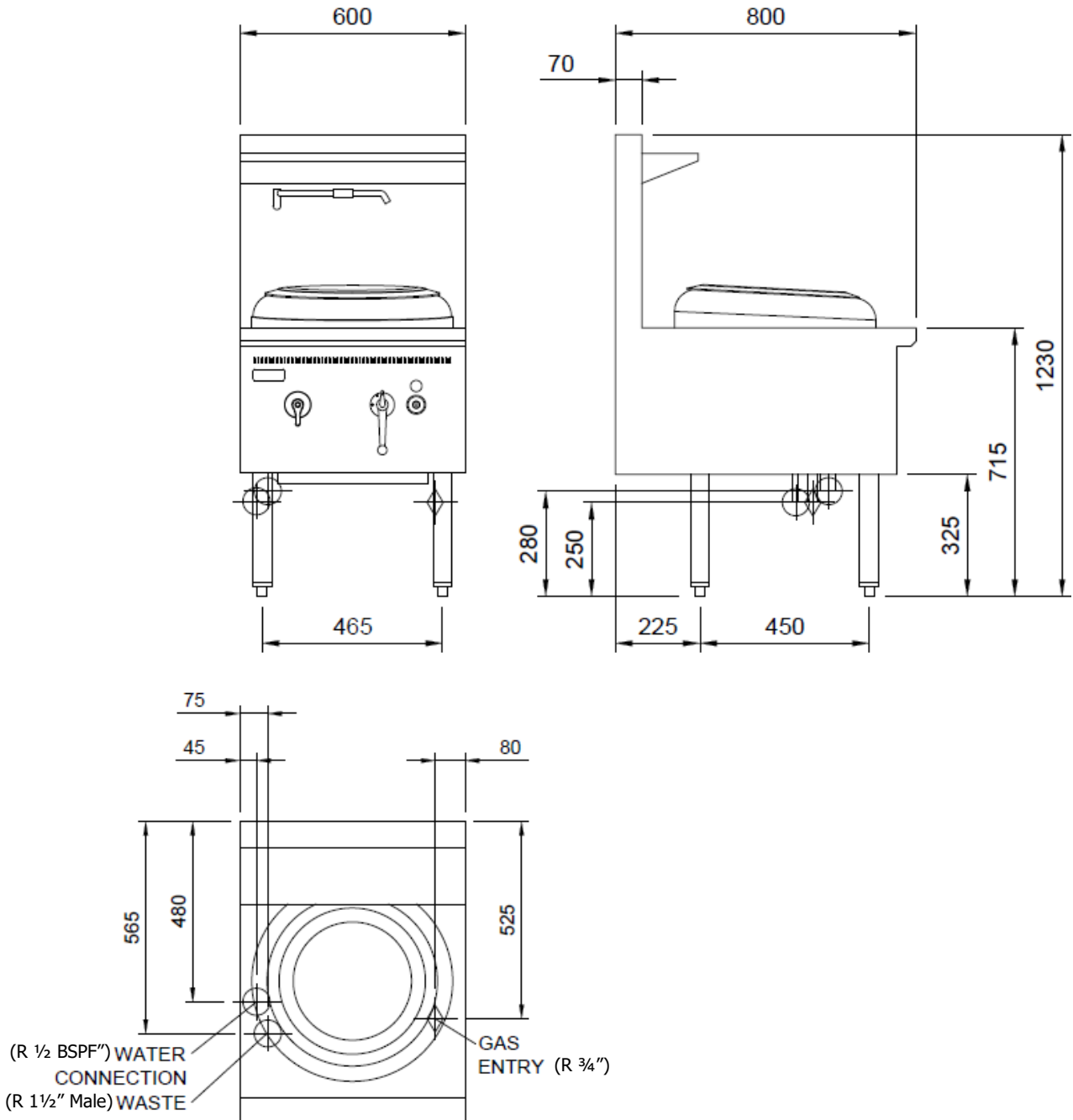

Overall Dimensions	
Height over Splashback.	1230mm (depending on Leg Adjustment).
Width.	600mm.
Depth.	800mm.
Height to Bench.	715mm (depending on Leg Adjustment).
Leg Height.	325mm (Adjustable).
Wok Hole Size.	14" Nominal.
Wok Capacity	Suits 40 - 60 cm (16" - 24") Wok

Cobra Two Hole Wok Model

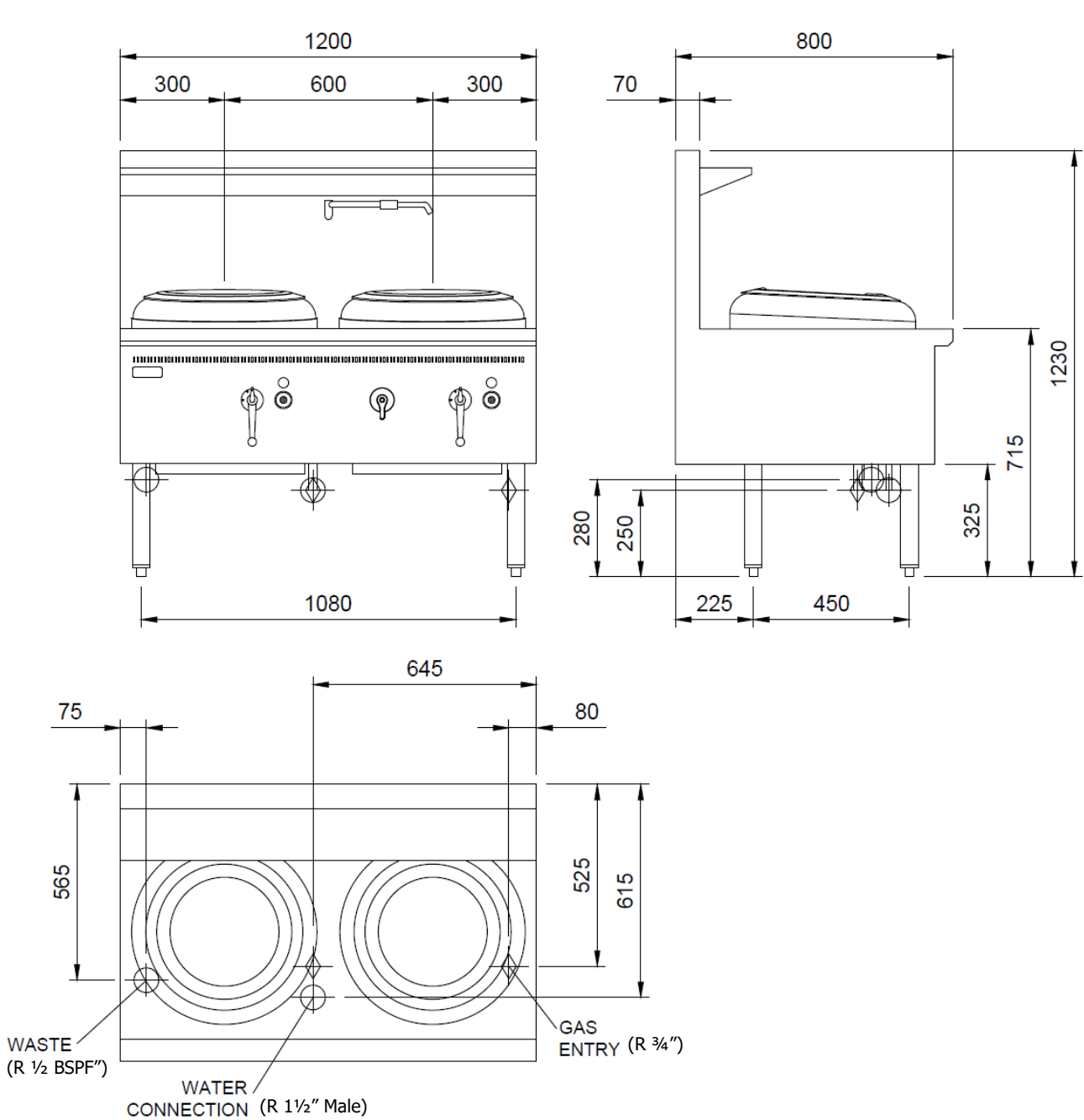

Overall Dimensions	
Height over Splashback	1230mm (depending on Leg Adjustment).
Width	1200mm.
Depth	800mm.
Height to Bench	715mm (depending on Leg Adjustment).
Leg Height.	325mm (Adjustable).
Wok Hole Size.	14" Nominal.
Wok Capacity	Suits 40 - 60 cm (16" - 24" Wok)

Specifications

Cobra Three Hole Wok Model

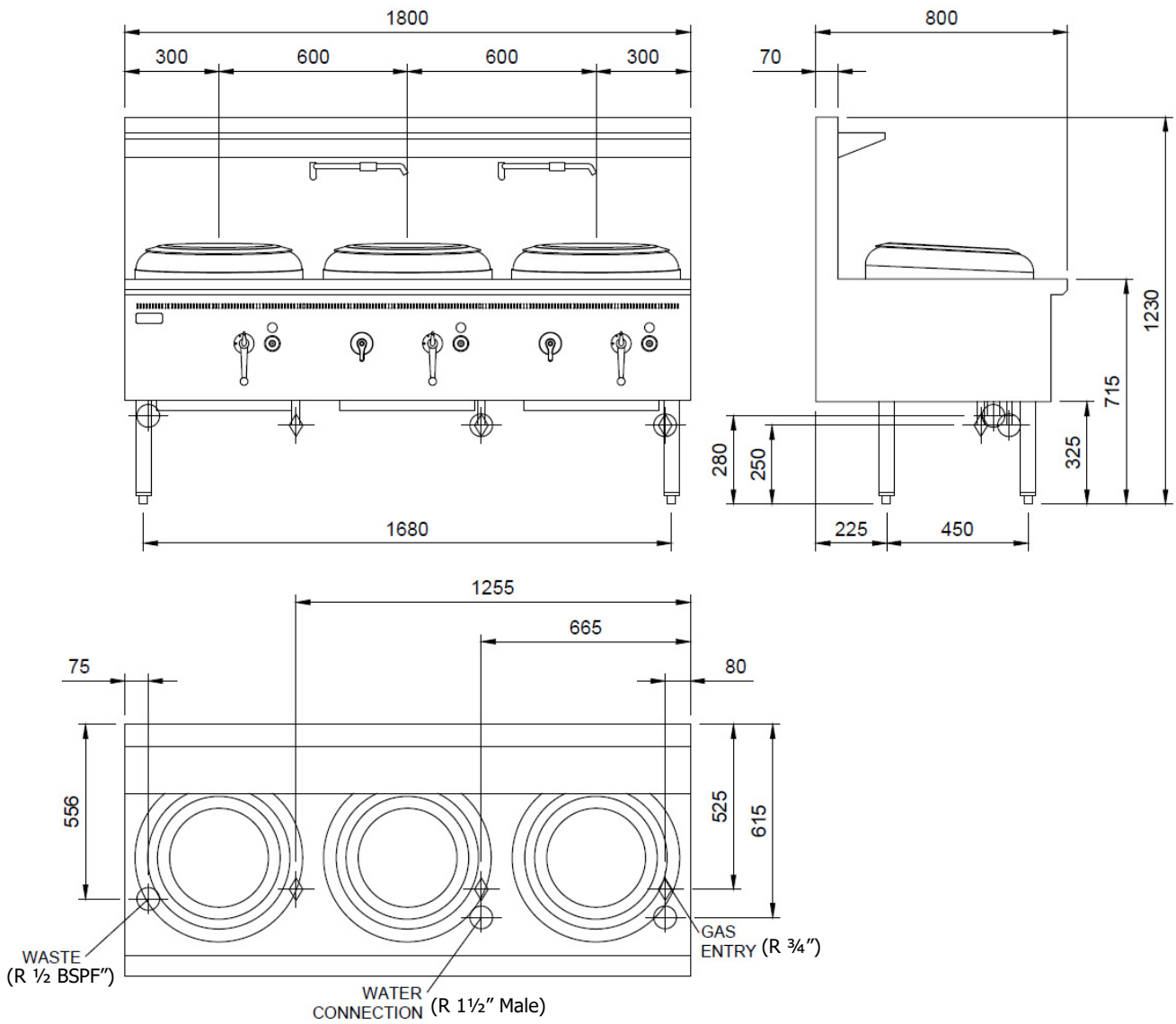

Overall Dimensions	
Height over Splashback	1230mm (depending on Leg Adjustment).
Width	1800mm.
Depth	800mm.
Height to Bench	715mm (depending on Leg Adjustment).
Leg Height	325mm (Adjustable).
Wok Hole Size.	14" Nominal.
Wok Capacity	Suits 40 - 60 cm (16" - 24" Wok)

Installation Requirements

NOTE:

It is most important that this appliance is installed correctly and that operation is correct before use. Installation shall comply with local, gas, health and safety requirements.

This appliance shall be installed with sufficient ventilation to prevent the occurrence of unacceptable concentrations of health harmful substances in the room, the appliance is installed in.

Cobra Gas Woks are designed to provide years of satisfactory service and correct installation is essential to achieve the best performance, efficiency and trouble-free operation.

It is strongly recommended that the appliance is installed under an extraction hood with a minimum clearance of 1200mm to the grease filter.

This appliance must be installed in accordance with National installation codes and in addition, in accordance with relevant National / Local codes covering gas and fire safety.

Australia / New Zealand:

AS/NZS 5601- Gas Installations.

Installations must be carried out by qualified service persons only. Failure to install equipment to the relevant codes and manufacturer's specifications shown in this section will void the warranty.

Components having adjustments protected (e.g. paint sealed) by manufacturer, are only to be adjusted by a qualified service agent. They are not to be adjusted by the installation person.

Unpacking

- Remove all packaging and transit protection from the appliance including all protective plastic coating from the outer panels and exterior stainless steel panels.
- Check the equipment and parts for damage. Report any damage immediately to the carrier and distributor.
- Report any deficiencies to the distributor who supplied the appliance.
- Check that the available gas supply is correct to that shown on the rating plate located on the lower RH Side of the appliance.
- Check that the following parts have been supplied with the appliance:-

Wok Rest.

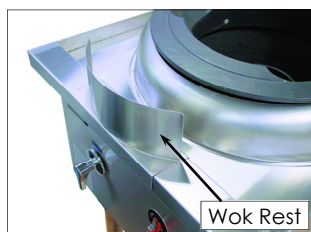

Location

- This appliance must be installed in a suitably ventilated room to prevent dangerous build up of combustion products.
- Installation must allow for a sufficient flow of fresh air for the combustion air supply.

Combustible Air Requirements

	CW1H	CW2H	CW3H
Natural Gas	27m ³ /hr min.	54m ³ /hr min.	81m ³ /hr min.
LP Gas	28m ³ /hr min.	56m ³ /hr min.	84m ³ /hr min.

- The appliance must be installed on a fire proof base.
- Position the appliance in its approximate working position.
- All air for burner combustion is supplied through the base area of the appliance. Refer to tables in Gas Conversion and Specifications Section.
- The legs must always be fitted and no obstructions placed on the underside or around the base of the appliance, as obstructions will cause incorrect operation and / or failure of the appliance.
- Components having adjustments protected (e.g. paint sealed) by manufacturer are only allowed to be adjusted by a qualified service agent. They are not to be adjusted by the installation person.

Clearances

NOTE:

Only non-combustible materials can be used in close proximity to this appliance.

To facilitate easy operation, drainage and servicing of the Wok, a minimum of 600mm clearance should be maintained at the front of the appliance.

Any gas burning appliance requires adequate clearance and ventilation for optimum and trouble-free operation. The following minimum installation clearances are to be adhered to:

	Combustible Surface	Non Combustible Surface
LH / RH Side	250mm	0mm
Rear	0mm	0mm
Floor Base	Non Combustable Fire Proof Base.	

Installation

Gas Connection

NOTE:

ALL GAS FITTING MUST ONLY BE CARRIED OUT BY A QUALIFIED SERVICE PERSON.

1. Cobra Woks do not require an electrical connection, they function totally on the gas supply only.
2. It is essential that the gas supply is correct for the appliance to be installed and that adequate supply pressure and volume are available. The following checks should therefore be made before installation:-
 - a. **The Gas Type** the appliance has been supplied for is shown on coloured stickers located above the gas entry point and next to the rating plate. Check that this is correct for the gas supply the appliance is being installed for. The gas conversion procedure is detailed in the 'Gas Conversion Section' at the rear of this manual.
 - b. **Supply Pressure** required for this appliance is shown in the 'Specifications' section of this manual. Check the gas supply to ensure that adequate supply pressure exists.
 - c. **Input Rate** of this appliance is also shown on the Rating Plate fitted to the lower RH side of the appliance and in the 'Specifications' section of this manual. The input rate should be checked against the available gas supply line capacity. **Particular note should be taken if the appliance is being added to an existing installation.**

NOTE:

It is important that adequately sized piping runs directly to the gas connection joint on the appliance, with as few tees and elbows as possible to give maximum supply volume.

3. Fit the supplied gas regulator into gas supply line as close to the appliance as possible.

NOTE:

The gas pressure regulator provided with this appliance is convertible between Natural Gas and LPG as per 'Gas Conversion Section' in this manual.

Ensure regulator is converted to the correct gas type that the appliance will operate on.

Regulator outlet pressure is fixed ex-factory for gas type that regulator is converted to and it is NOT to be adjusted.

Regulator connections are $\frac{3}{4}$ " BSP female.

Connection to appliance is $\frac{3}{4}$ " BSP male.

(Refer to 'Specifications' section for gas supply connection location).

4. A suitable joining compound which resists the breakdown action of LPG must be used on every gas line connection, unless compression fittings are used.

NOTE:

A Manual Isolation Valve must be fitted to individual appliance supply line.

5. Locate the appliance into its final operating position and using a spirit level, adjust the legs so that the unit is level and at the correct height.
6. Connect the gas supply to each individual wok burner of the appliance.
7. Check Burner Operating Pressure is as shown in the 'Specifications' section, 'Gas Supply Requirements' tables. (Measure at the 'Operating Pressure Test Point' on the individual gas regulator for each separate wok burner).
8. Check all gas connections for leakages using soapy water or other gas detecting equipment, with the main burner operating.

WARNING:

DO NOT USE A NAKED FLAME TO CHECK FOR GAS LEAKAGES.

NOTE:

Measure the operating pressure at the Pressure Test Point on the gas regulator, (Separate Gas Regulator fitted for each burner) this is to be carried out with main burner operating at 'High Flame' setting. Operating pressure is ex-factory set, through the appliance regulator and is not to be adjusted, apart from when carrying out gas conversion, if required. Refer to 'Gas Conversion and Specification' Section for further details.

9. Verify the operating pressure remains correct.
10. Check pilot flame size and adjust as required by removing the Blanking Screw on the base of the pilot burner and using a flat blade screwdriver, adjust the pilot adjusting screw as follows:-

Rotate clockwise - to decrease flame size.

Rotate anti-clockwise - to increase flame size.

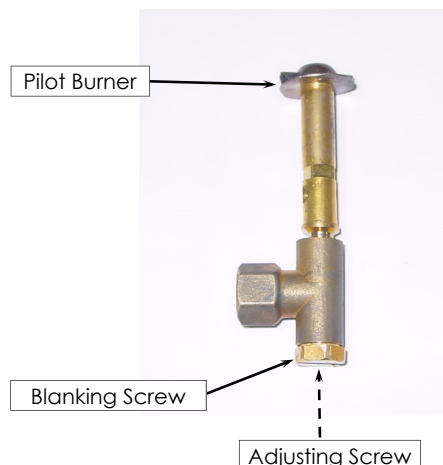

Water Connection

NOTE:

Water connection shall be installed in accordance with local water regulations in force and the applicable standard / code, e.g. PCA in Australia.

A cold water supply must be connected to the water inlet connection (R 1/2" BSP), located as shown in the drawings in the 'Specifications Section'.

Water connection should be plumbed, in accordance with National / Local Codes covering installation.

Water inlet pressure must be as follows:-

Minimum water supply pressure 150 kPa (22 psi).

Maximum water supply pressure 550 kPa (80 psi).

Drainage Connection

Waste water is drained from the appliance work surface by means of a waste water collection system at the rear of the work surface.

Each model is fitted with a drain / overflow outlet on the left underside of the appliance.

The drain outlet can be extended in order to exit above a tundish or can be plumbed to a drain outlet.

Drain connection is 1 1/2" BSP, drain / overflow.

Commissioning

The following commissioning checks must be carried out before the Gas Wok is handed over for use, to ensure the unit operates correctly and the operator(s) understand the correct operating procedure.

1. Before leaving new installation;
 - a. Check the following functions in accordance with operating instructions specified in 'Operation' section of this manual.
 - Light the Pilot Burners.
 - Light the Main Burners.
 - b. Ensure that each operator has been instructed in areas of correct lighting, operation and shutdown procedures for the appliance.
2. This manual must be kept by the owner for future reference and a record of **Date of Purchase**, **Date of Installation** and **Serial Number of Unit** recorded and kept with this manual. **(These details can be found on Rating Plate attached to lower R/H side of side panel.**

NOTE:

If it is not possible to get the appliance to operate correctly, shut 'Off' the gas supply and contact the supplier of this unit.

Operation

Operation Guide

WARNING:

GREAT CARE MUST BE TAKEN BY OPERATOR, TO USE THE GAS WOK SAFELY, TO GUARD AGAINST RISK OF INJURY AND FIRE.

- **USER CARE IS REQUIRED WHEN TURNING 'ON' THE MAIN BURNER'S OPEN FLAME.**
- **DO NOT LEAVE THE GAS WOK UNATTENDED DURING OPERATION.**
- **TURN 'OFF' THE MAIN BURNER FLAME BEFORE REMOVING THE WOK POT FROM THE BURNER.**
- **DO NOT USE FLAMMIBLE SOLVENTS AND CLEANING AIDS ON OR IN CLOSE PROXIMITY TO THE GAS WOK WHILST THE WOK IS STILL HOT.**

CAUTION:

- **This appliance is for professional use and is only to be used by qualified persons.**
- **Only qualified service persons are to carry out installation, servicing or gas conversion operations.**
- **Components having adjustments protected (e.g. paint sealed) by the manufacturer should not be adjusted by the user / operator.**

1. Cobra Gas Woks have been designed to provide simplicity of operation and 100% safety protection.
2. Improper operation is almost impossible, however bad operation practices can produce a poor quality product. To use this Gas Wok correctly, please read the following sections carefully;

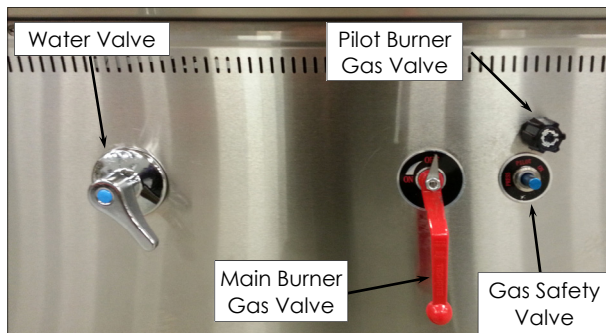

Description of Controls

- A commercial heavy duty, gas fired, high performance Wok designed for Asian style commercial cooking, using LPG (Propane) or Natural Gas.
- The Wok is available in 3 variants, Single Burner, Twin Burner or Triple Burner. Each of which can be fitted with either a Chimney or Duckbill style burner or a combination of both burner styles.
- Each model is fitted with a main burner, a pilot burner and is controlled by a single main burner gas valve with flame failure protection to control both the main burner and pilot burner.

Using the Telescopic Water Filling Arm

The Telescopic Water Filling Arm can be used for filling the Wok cooking pans with water for cooking purposes, or can be used for cleaning down the Wok table at the end of the cooking process.

CAUTION:

- **When using the Water Filling Arm, avoid water entering the gas system through the main burner as this will cause damage to the gas controls.**
- **The Water Filling Arm is to be used only for filling cooking receptacles or for cleaning the Wok cooking surfaces. The Wok does not require continuous water flow over the Wok table.**
- **When using the Water Filling Arm, do not leave the Wok unattended as water spillage may enter the burners and cause damage to the gas controls.**

1. To operate the Water Valve facility on the Wok, a Water Valve is provided on the control panel.
2. An adjustable Water Filling Arm is provided on the splashback which can be used to fill receptacles or for Wok cleaning.

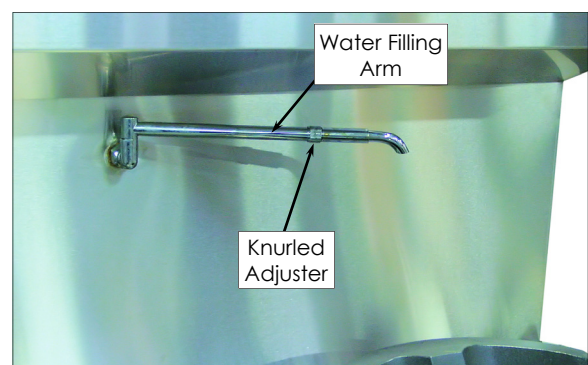

3. To operate the Water Filling Arm, swing the arm over the cooking pan or where required. The length of the arm can be adjusted by slackening the knurled adjuster on the arm.
4. Pull out the front part of the arm to extend the arm and tighten the adjuster.
5. On the Control Panel, turn the Water Valve anti-clockwise to the 'On' position, water will flow from the Water Filling Arm.
6. When the Water Filling Arm is not in use, move the arm back against the splashback to prevent damage to the arm and exposure to the heat from the Wok burners.



Turning 'Off' the Main Burner

1. Turn the Main Burner Gas Valve anti-clockwise to the 'Off' position, the Main Burner will extinguish.
2. The Pilot Burner will still be 'On'.

Turning 'Off' the Pilot Burner

1. Turn the Pilot Burner Gas Valve clockwise to the 'Off' position, the Pilot Burner will extinguish.
2. Turn 'Off' the gas supply at the mains supply.

Lighting the Pilot Burner

1. Check gas supply is turned 'On' at the mains supply.
2. Ensure that the Main Burner Gas Valve is in the 'Off' position.
3. Rotate the Pilot Burner Gas Valve anti-clockwise to the 'On' position.
4. Press and hold the Gas Safety Valve depressed and manually light the Pilot Burner.
5. Keep holding the Gas Safety Valve depressed for 30 seconds after the pilot burner is lit, to allow the thermocouple to warm up.
6. Release the Gas Safety Valve, the pilot burner should remain alight.
7. If the pilot burner does not ignite, repeat Items 3 to 6 above.

Lighting the Main Burner

CAUTION:

Do Not lean over the Wok Main Burner when lighting the burner as the main burner flame is very hot.

1. Turn 'On' the Main Burner Gas Valve anti-clockwise to the setting required to suit the cooking requirements. The main burner will ignite.

CAUTION:

During operation, take care to ensure that no food product or oil fall into the burner area during the cooking process as this can affect the safe operation and efficiency of the burners and pilot assembly.

Cleaning and Maintenance

General

WARNING:

DO NOT USE FLAMMIBLE SOLVENTS AND CLEANING AIDS ON OR IN CLOSE PROXIMITY TO THE GAS WOK WHILST THE APPLIANCE IS STILL HOT.

CAUTION:

Always turn 'Off' the gas supply at the mains supply before cleaning.

This appliance is not water proof. Do not use water jet spray to clean interior or exterior of this appliance.

If cleaning detergents enter inner parts of appliance, rusting will occur on pipe work, installation elements, burners and gas fittings, this will cause premature failure of the appliance.

To keep your gas Wok clean and operating at peak efficiency, observe the following procedures:-

NOTE:

- **DO NOT clean appliance using high pressure water or steam jets.**
- **DO NOT pour water directly over the appliance.**
- **DO NOT use wire brushes.**
- **DO NOT use combustible liquids to clean appliance.**
- **DO NOT use harsh abrasive detergents, sharp scrapers, strong solvents or caustic detergents as they will damage appliance.**
- **DO NOT use any chloric or bleaching detergents to clean appliance.**
- **Ensure that any detergent or cleaning material have been completely removed after each cleaning.**
- **DO NOT use saline or sulfuric acid preparations for descaling the appliance.**
- **Ensure that protective gloves are worn during the cleaning process.**
- **Clean the wok table regularly after each use.**

Daily Cleaning

1. Clean the work surfaces of the Wok, regularly at the end of each day. Do not use wire brushes on the work surfaces. Clean using a mild detergent and a hot water solution using soft cloth or a soft bristled brush. Dry the appliance thoroughly using a dry clean cloth.
2. Any waste water from cleaning the Wok table, will drain into the appliance drain outlet below the appliance, ensure that the drain is kept clear of any waste food product.
3. Clean the control panel using a damp cloth lightly moistened with a solution of mild detergent and hot water.

4. Dry the control panel thoroughly using a dry clean cloth.
5. At the end of each day or at end of each shift, clean the exterior of the Gas Wok using a mild detergent and hot water solution using soft cloth or a soft bristled brush.
6. Check the main burners daily for any food spillage and burnt- on material. Clean the burners on a regular basis using a soft bristled brush. DO NOT allow water to enter the burners.
7. Remove, empty and wash out the spill trays using a solution of mild detergent and hot water.
8. Dry the spill tray thoroughly using a dry clean cloth and refit to the Wok.

Weekly Cleaning

NOTE:

- **If the Gas Wok usage is very high, we recommend that the weekly cleaning procedure is carried out more frequently.**
- **Ensure protective gloves are worn during cleaning.**
- **DO NOT use harsh abrasive detergents, strong solvents, sharp scrapers or caustic detergents as they will damage the surface of the Gas Wok.**

Chimney and Wok Ring

1. The Chimney / Wok Ring can be removed for cleaning.
2. Clean the Chimney/ Wok Ring thoroughly with a flexible spatula.
3. A scraper tool can be used to remove stubborn carbon and deposits.
4. Wash with hot water, a recommended detergent solution and a scrubbing brush.
5. Dry all components thoroughly with a dry cloth.

Stainless Steel Surfaces

Thoroughly clean the interior and exterior of the Gas Wok regularly. Do not use wire brushes on the pan. Clean using a mild detergent and a hot water solution using a soft cloth or soft bristled brush. Dry the appliance thoroughly using a dry clean cloth.

NOTE: In order to prevent rust forming on the steel components, ensure that the detergent or cleaning material has been entirely removed after each cleaning process.

1. Clean the interior and exterior surfaces of the Gas Wok with hot water, a mild detergent solution and a soft scrubbing brush.
2. Baked on deposits or discolouration may require a good quality stainless steel cleaner or stainless steel wool. Always apply cleaner when the appliance is cold and rub in direction of the grain.
3. Dry all components thoroughly with a dry cloth and polish with a soft dry cloth.

Periodic Maintenance

NOTE:

All maintenance operations should only be carried out by a qualified service person.

To achieve the best results, cleaning must be regular and thorough and all controls and mechanical parts should be checked and adjusted periodically by a qualified service person.

If any small faults occur, have them attended to promptly. Don't wait until they cause a complete breakdown.

It is recommended that the appliance is serviced every 12 months.

If appliance is not used for long periods, close the gas shut-off valve upstream of the appliance and clean the appliance thoroughly.

Fault Finding

This section provides an easy reference guide to the more common problems that may occur during operation of your equipment. The fault finding guide in this section is intended to help you correct, or at least accurately diagnose problems with your equipment.

Although this section covers the most common problems reported, you may encounter a problem not covered in this section. In such instances, please contact your local authorised service agent who will make every effort to help you identify and resolve the problem. Please note that the service agent will require the following information:-

- **Model Trade Name and Serial Number of the Appliance. (both can be found on the Technical Data Plate located on the appliance.**

Fault	Possible Cause	Remedy
Pilot Burner will not ignite or ignites with difficulty and will not stay alight.	Check gas supply is turned ' On '.	Turn ' On ' the gas supply.
	Check gas supply is low or empty.	Replenish gas supply.
	Thermocouple connection loose.	Tighten thermocouple connection. Replace any damaged connectors.
	If sufficient pilot flame cannot be obtained, remove pilot orifice from pilot burner and check for blockage of pilot burner and /or gas line also check that correct size gas pipe has been used.	If connections OK, check for gas at pilot burner by manually lighting pilot burner. Call service provider.
	If pilot can be lit but flame too small to impinge on thermocouple.	Check pilot injector for restriction. Clean or replace Pilot Injector. Check gas supply.
	If pilot flame OK but goes out after gas safety valve is released (after holding in for approx. 30 secs).	Check for faulty thermocouple. Call service provider.
	If all of above in pilot and thermocouple system checks out satisfactorily but problem still persists.	Gas control valve is defective and needs replacement.
Pilot Burner delay in ignition of main burners.	Check operating pressure as stated in 'Installation' section.	Check gas supply. Call service provider.
	Check pilot flame size.	Pilot flame for main burner ignition should be approximately 1 inch long. Check pilot burner injector size is correct. (See 'Specifications' section). Check pilot injector for restriction. Clean or replace Pilot Injector.

Gas Conversion and Specifications

Gas Conversion Procedure

CAUTION:

Ensure that the Unit is isolated from the gas supply before commencing servicing.

NOTE:

- These conversions should only be carried out by qualified persons. All connections must be checked for leaks before re-commissioning the appliance.
- Adjustment of components that have adjustments / settings sealed (e.g. paint sealed) can only be adjusted in accordance with the following instructions and shall be re-sealed before re-commissioning this appliance.
- For relevant gas specifications refer to 'Gas Specifications Tables' at rear of this section.

Gas Regulator

- NAT Gas / LPG Only.

1. Unscrew cap on regulator and rotate pin to the setting shown in 'Gas Specifications' tables overleaf.
2. Refit cap to regulator.

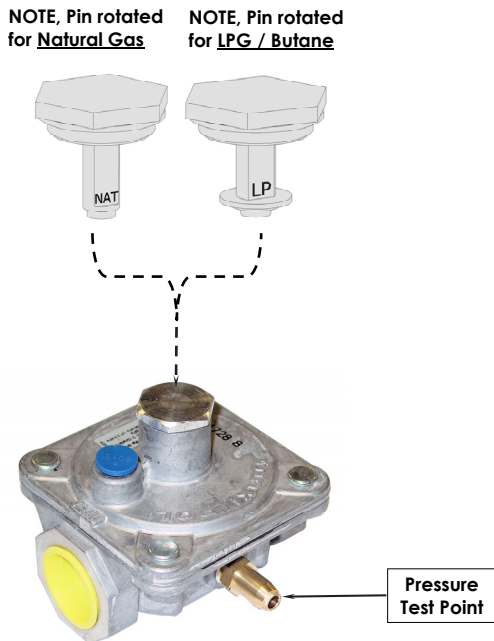

NOTE:

- Gas regulator supplied is convertible between Natural Gas and LP Gas, but it's outlet pressure is fixed ex-factory and is NOT to be adjusted.
- This Gas Regulator is fitted with a Pressure Test Point on the inlet side of the regulator. This is to be used when checking inlet pressure.

Main Burner

1. For both types of burners, lift out and remove the Wok ring from the appliance.

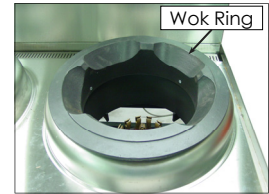

Duckbill Burners Only;

2. Unscrew the main burner from the gas supply pipe and remove the burner complete.

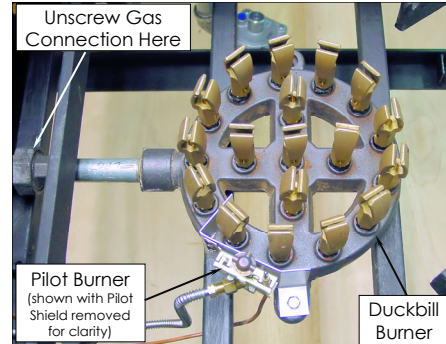

3. Replace with correct main burner for the gas being used. **Refer to Gas Specifications Table.**

Chimney Burners Only;

4. Lift Off and remove the chimney which sits over The main chimney burner.

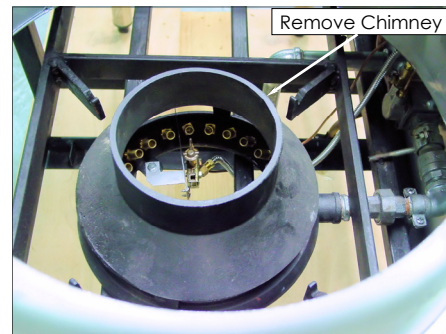

5. Unscrew the main burner from the gas supply pipe and remove the burner complete.

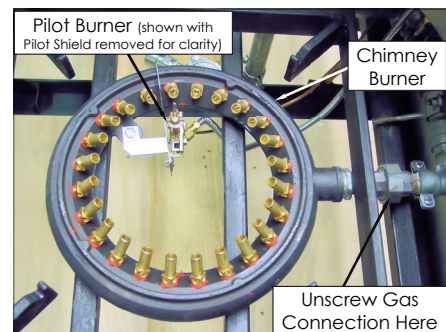

6. Replace with correct main burner for gas type being used. **Refer to Gas Specifications Table.**
7. Refit the chimney which sits over the main burner.

For Both Burners;

8. Refit the Wok ring, ensure it is correctly located onto the burner frame with the wide part of ring at the front of the wok.

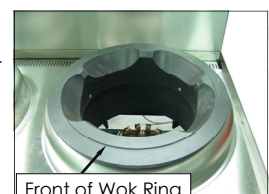

Gas Conversion and Specifications

Pilot Burner Flame Adjustment

1. Unscrew and remove the blanking screw at the base of the pilot assembly.
2. Light the pilot burner as shown in the 'Operation Section'.
3. Using a small flat bladed screw driver, adjust the pilot burner flame so that it impinges on the thermocouple sufficiently to envelop the thermocouple with flame.
4. Turn 'Off' the Pilot Burner and refit the blanking screw to the base of the pilot assembly.
5. Re-light the pilot and ensure the flame is the correct size.



Gas Type Labels

On completion of gas conversion, replace the gas type labels located at:-

- Rear of unit, above the gas connection.
- Beside the rating plate.

Commissioning

Before leaving the installation;

1. Check all gas connections, including the pilot and each individual burner injector base connection, for leakage using soapy water or other gas detecting equipment.

WARNING:

DO NOT USE A NAKED FLAME TO CHECK FOR GAS LEAKAGES.

2. Carry out a 'Commissioning' check of the appliance as shown in Installation Section of this manual.
3. Ensure any adjustments done to components that have adjustments / settings paint sealed, these are to be re-sealed.



NOTE:

If it is not possible to get the appliance to operate correctly, shut 'Off' gas supply and contact supplier of this appliance.



Gas Conversion and Specifications

Gas Specifications



- Australia

	Burner Type	Natural Gas.	LPG (Propane)
Main Burner Injectors	WC (Wok Chimney)	Ø 0.95mm	Ø 0.60mm
	WD (Wok Duckbill)	Ø 1.25mm	Ø 0.75mm
Main Burner Injectors (Qty)	WC (Wok Chimney)	24	24
	WD (Wok Duckbill)	18	18
Main Burner Primary Air	WC (Wok Chimney)	5.0mm	6.0mm
	WD (Wok Duckbill)	6.0mm	6.0mm
Pilot Burner Adjustment (**)		Variable	Variable
Supply Pressure		1.13 - 3.40 kPa	2.75 - 4.50 kPa
Burner Operating Pressure (*)		1.00 kPa	2.65 kPa
Gas Regulator Cap Screw			

- New Zealand:

	Burner Type	Natural Gas.	LP Gas
Main Burner Injectors	WC (Wok Chimney)	Ø 0.95mm	N/A
	WD (Wok Duckbill)	Ø 1.25mm	Ø 0.70mm
Main Burner Injectors (Qty)	WC (Wok Chimney)	24	N/A
	WD (Wok Duckbill)	18	18
Main Burner Primary Air	WC (Wok Chimney)	5.0mm	N/A
	WD (Wok Duckbill)	6.0mm	6.0mm
Pilot Burner Adjustment (**)		Variable	Variable
Supply Pressure		1.13 - 3.40 kPa	2.75 - 4.50 kPa
Burner Operating Pressure (*)		1.00 kPa	2.65 kPa
Gas Regulator Cap Screw			

- All Other Markets:

	Burner Type	Natural Gas.	LPG (Propane)	Butane
Main Burner Injectors	WC (Wok Chimney)	Ø 0.95mm	Ø 0.60mm	N/A
	WD (Wok Duckbill)	Ø 1.25mm	Ø 0.75mm	Ø 0.70mm
Main Burner Injectors (Qty)	WC (Wok Chimney)	24	24	N/A
	WD (Wok Duckbill)	18	18	18
Main Burner Primary Air	WC (Wok Chimney)	5.0mm	6.0mm	N/A
	WD (Wok Duckbill)	6.0mm	6.0mm	6.0mm
Pilot Burner Adjustment (**)		Variable	Variable	
Supply Pressure		1.13 - 3.40 kPa	2.75 - 4.50 kPa	
Burner Operating Pressure (*)		1.00 kPa	2.65 kPa	
Gas Regulator Cap Screw				

NOTE: (*) Measure burner operating pressure at the test point (Burner Operating Pressure) on the gas regulator, this is to be carried out with the main burner operating at 'High Flame' setting. Operating pressure is ex-factory set, through the appliance regulator and is not to be adjusted, apart from when carrying out gas conversion, if required. Refer to the details in this section for further details.

(**) Adjust Pilot Burner as required to suit the type of gas being used.

Replacement Parts List

Replacement Parts List

IMPORTANT:

Only genuine qualified replacement parts should be used for the servicing and repair of this appliance. The instructions supplied with the parts should be followed when replacing components. For further information and servicing instructions, contact your nearest qualified service branch (contact details are as shown on the reverse of the front cover of this manual).

When ordering spare parts, please quote part number and description as listed below. If part required is not listed below, request part by description and quote model number and serial number which is shown on Rating Plate.

Part No.	Description
241339	WOK REST
240864	SPILL TRAY WOK
241415	DRAIN CHANNEL COVER (CW1H)
241416	DRAIN CHANNEL COVER (CW2H)
241417	DRAIN CHANNEL COVER HALF (CW3H)
241409	PILOT HOOD
240862	WOK RING COBRA
241404	CHIMNEY CASTING
240887	BURNER CHIMNEY 24 JET 0.60mm LPG (Propane) - AU / XP
240866	BURNER CHIMNEY 24 JET 0.95mm NAT
240869	PIPE CONNECTION KIT BURNER CHIMNEY
240867	INJECTOR 0.60mm CHIMNEY - LPG (Propane) - AU / XP
240868	INJECTOR 0.95mm CHIMNEY - NAT
241329	BURNER DUCKBILL 18 JET 0.75mm LPG (Propane) - AU / XP
241411	BURNER DUCKBILL 18 JET 0.70mm LPG (NZ) / BUTANE
240872	BURNER DUCKBILL 18 JET 1.25mm NAT
240876	PIPE CONNECTION KIT BURNER DUCKBILL
240926	NOZZLE DUCKBILL 6mm x 6mm
241323	INJECTOR 0.75mm DUCKBILL - LPG (Propane) - AU / XP
241412	INJECTOR 0.70mm DUCKBILL - LPG (NZ) / BUTANE
240875	INJECTOR 1.25mm DUCKBILL - NAT
237077	FLEX TUBE STST ¼" x 18"
240877	GAS VALVE ¾" BSP - LEVER HANDLE
240878	VALVE HANDLE LEVER WOK / STOCKPOT
241405	POINTER - VALVE HANDLE
240879	PILOT ON-OFF VALVE KEEFER PT-46
240880	KNOB PILOT VALVE
240881	SAFETY VALVE D3, ¾"
240882	PILOT BURNER ASSY
240883	THERMOCOUPLE
240884	WATER SWIVEL ARM, WOK / STOCKPOT
240885	DECAL BURNER ON-OFF
240886	DECAL SAFETY VALVE
241333	LEG COBRA WOK
010990	ADJUSTABLE FOOT (for Leg Stock Pot)

Conversion Kits - Burner / Gas Type Conversion:

Burner Type	1Kit Required for each Wok Hole		
	Nat. Gas	LPG (Propane)	LPG (NZ) / BUTANE
Chimney	241433	241432	N/A
Duckbill	241429	241428	241427

