

European advanced servo-drive technology, the new generation of high efficiency, energy-saving, environmental protection CNC servo turret punch. Probably the best price/quality ratio in the world!

## DINAMICA - DINAMICA LASER



**DERATECH**

# DERATECH

Company  
Introduction

PROBABLY THE BEST PRICE/QUALITY  
RATIO IN THE WORLD!





## DERATECH GROUP

Deratech is specialized in designing and manufacturing sheet metal working machines. The Deratech headquarters for research, design and assembly are based in Belgium. Subsidiaries all over the world (Australia, China, Germany, Netherlands, Thailand, ...) and carefully selected partners provide a world class advice, sales installation and service.

Shanghai Deratech CNC Machine Tool Co. Ltd, is the new production & technology center of Deratech - Belgium in China. The advanced European design, quality and technology of our R&D center in Belgium together the experienced engineering team of Shanghai Deratech will result in high quality production of sheet metal working machinery. All processing is designed in 3D by our technical department to obtain a high precision on all the manufactured machine parts.

**Deratech is your partner in sheet metal working machinery.**

THE NEW GENERATION OF HIGH  
EFFICIENCY SERVO-DRIVE TURRET  
PUNCHING TECHNOLOGY,  
ENERGY EFFICIENCY, VERSATILITY  
AND ACCURACY AND LOW  
MAINTENANCE COST.



# DINAMICA

DINAMICA / DS



# PRODUCT FEATURES

1

The servo-mechanically driven punching stroke is CNC-controlled, resulting in an unmatched high-performance punching, energy saving, superior reliability, outstandingly accurate forming capacity. **Saving up to 60% of electrical power over typical hydraulic machines.**

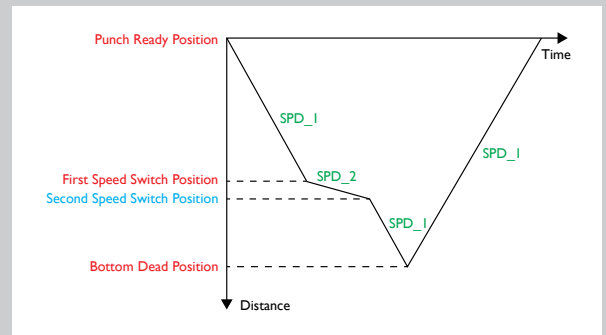
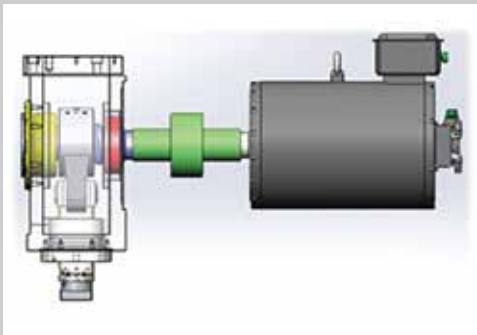

The servo-electrical punch ram allows programming of the punch operation according to the exact requirements:

- Soft punching with noise reduction
- High-speed nibbling and marking
- Accurate forming and wheel forming



2

The Heavy Duty "O" type frame is engineered to ensure tighter tolerances, distortion free parts and perfect tool alignment. Complete annealing of the frame after welding to eliminate internal stress. The frame is built to last a life time...



## 3

### TURRET

Thick turret tooling system provides high flexibility with superior guiding, extended tool life and a minimum tool maintenance. A maximum feed clearance between the upper and lower turret allows for the production of higher forms such as lances, louvers, emboss,...



## 4

The versatile mix of turret stations includes a High precision auto index, compact structure with gear drive. Available in D station.

### LAYOUT OF TURRET WORKING POSITION

Station Item	32 Station	Dimension area
A	16	$\phi 2 \sim \phi 12.7\text{mm}$
B	12	$\phi 12.7 \sim \phi 31.75\text{mm}$
C	2	$\phi 31.75 \sim \phi 50.8\text{mm}$
D	2	$\phi 50.8 \sim \phi 88.9\text{mm}$
D-INDEX	2	$\phi 50.8 \sim \phi 88.9\text{mm}$

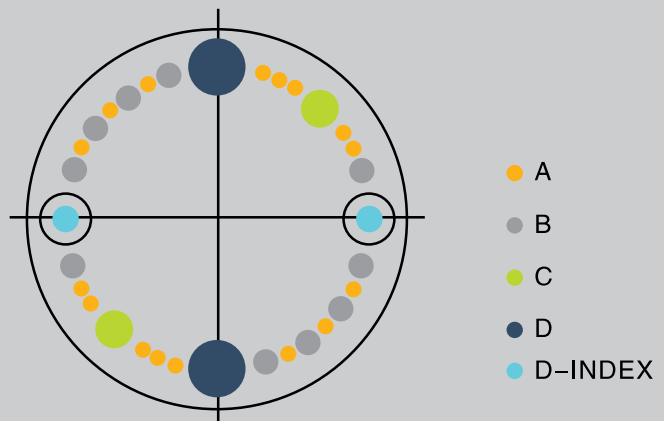

# PRODUCT FEATURES



5

## TURRET DRIVE

High precision compact drive system integrated in the machine frame.



6

## BRUSH WORKING TABLE

Large brush table design provides low noise during the punching operation, scratch-free processing, eliminating secondary finishing.



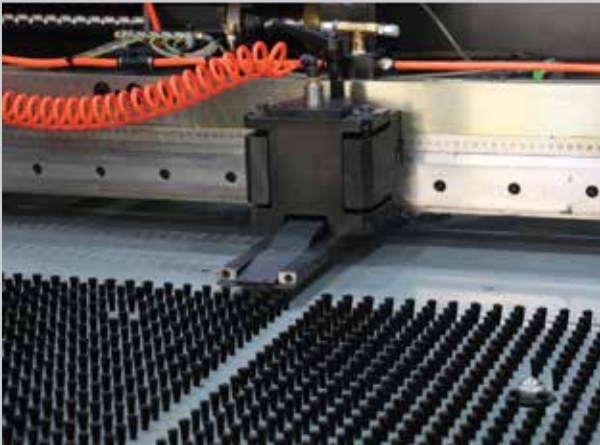

7

## FEED MECHANISM

A high technology positioning system provides heavy sheet carrying capacity and accurate motion control powered by a direct drive servo system for X,Y axis, with high precision ball screw and linear guide (Japan). High speed movement for X and Y with high positioning accuracy.



8

## CLAMPING

Movable pneumatic clamping.

# OPTIONS



1

Vacuum suction of the punch scraps: effectively suck out the punch scraps from the dies.

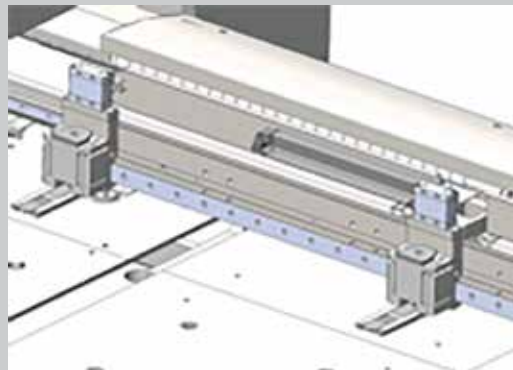

2

Automatic clamps reposition mechanism: allows the machine to automatically position the clamps on the carriage

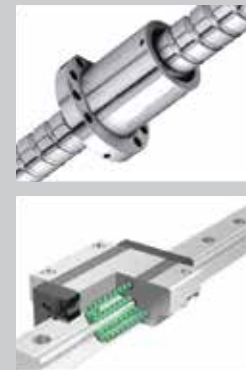

## CNC SYSTEM

### CONTROLSYSTEM

Free standing control system with integrated Siemens controller and a separate floor standing electric cabinet to reduce the effect of vibration during the operation of the machine.



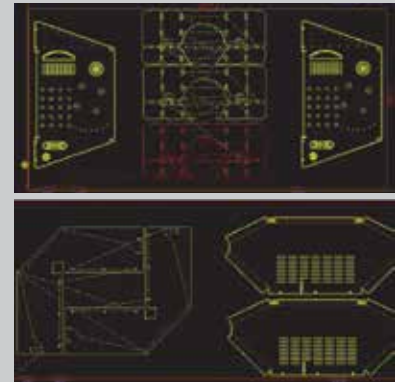

World-class Siemens CNC system and servo system to ensure precision and stable machine operation.

## Dinamica DS (2016)

Parameter Name	Unit	DAS2.1550	DAS3.1550	DAS2.2050	DAS3.2050
Press capacity	kN	200	300	200	300
The largest processing sheet size	mm	1500x5000	1500x5000	2000x5000	2000x5000
The Largest thickness	mm	6	6	6	6
Maximum hole (one-time punching)	mm	Ø88.9	Ø88.9	Ø88.9	Ø88.9
Position number		32(2AI)	32(2AI)	32(2AI)	32(2AI)
Maximum moving speed	mm/min	100 (X:80;Y:60)	100 (X:80;Y:60)	100 (X:80;Y:60)	100 (X:80;Y:60)
Turret speed	rpm	30	30	30	30
The punching frequency	hpm	1500	1500	1500	1500
The punching frequency (1mm pace, 4mm punching stroke)	hpm	700	700	700	700
The punching frequency (25mm pace, 4mm punching stroke)	hpm	350	350	350	350
Number of control axis		5	5	5	5
CNC system		Siemens	Siemens	Siemens	Siemens
Punching precision	mm	±0.10	±0.10	±0.10	±0.10
Pressure of gas	mpa	0,6	0,6	0,6	0,6
Dimensions	mm	5300×5210×2330	5300×5210×2330	6300×5210×2330	6300×5210×2330
Weight	kg	17000	17500	22500	23000

If you need more product specification please contact with us.

DINAMICA PUNCH-LASER  
COMBINES PUNCHING AND  
LASER TECHNOLOGY



# DINAMICA PUNCH-LASER



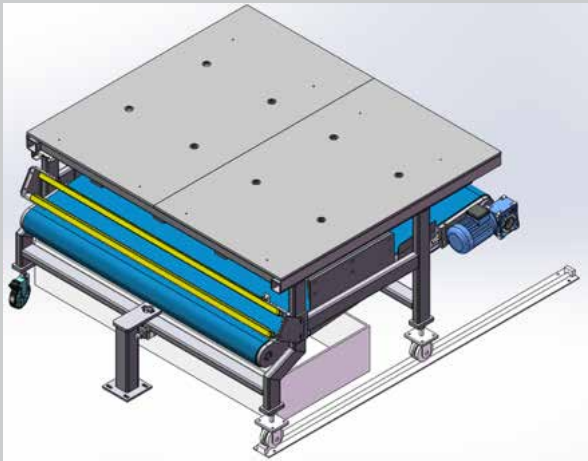

#### **PART SORTING DROP DOOR**

An automatic part sorting drop door of 500mm wide and 1500mm long is integrated in the laser cutting system. Laser cut parts smaller than the drop door can therefore automatically be removed from the sheet.



#### **PROGRAMMABLE SORTING CONVEYOR**

The programmable sorting conveyor is able to separate sorted parts from the big scraps. Scraps will be guided to a scrap box, finished parts will slide from the drop door and will then be transferred by the conveyor to a parts box. A light curtain is used to detect that the parts that need to be unloaded are effectively fully out of the unloading chute.

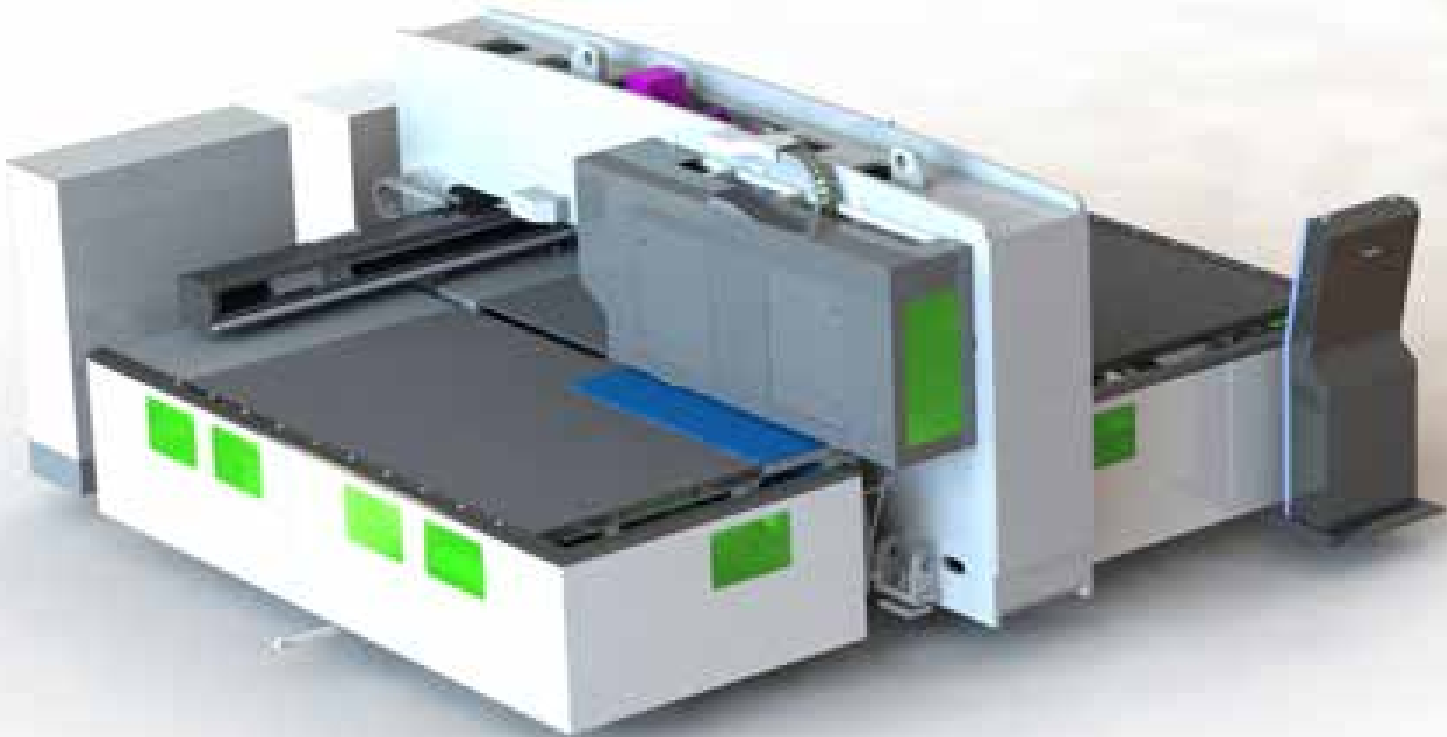

# DINAMICA PUNCH-LASER

## DYNAMIC LASER CUTTING AXIS

Precitec Cutting Head is installed on our state of the art Combi-machine. During laser cutting, the Y-axis movement of the carriage is replaced by the laser V-axis, which is much lighter, has a higher stiffness and allows a more dynamic and accurate interpolation of any laser cutting contour.

- It offers unbeatable productivity when processing holes
- There is the additional flexibility of laser cutting any free-form contours
- Also forming operations are possible
- Automatic part sorting is integrated
- Fiber laser technology combined with servo-electric punching guarantees low electrical consumption and minimal operating costs

ITEM	SPECIFICATION
Max. punching force	300kN
Max. laser power	4000W
Max. sheet thickness	6.35mm
Max. punch diameter	88.9mm
Max. sheet size (with repositioning)	5000mm x 1500mm
Max. sheet size (without repositioning)	2500mm x 1500mm
Max. sheet size combined punch and laser operation (without repositioning)	1835mm x 1500mm
Max. number of punch tools	32
Max. number of auto-index stations	2
Max. positioning speed	100m/min
Max. turret rotation speed	30rpm
Max. punching speed	1500hpm
Punching accuracy (without repositioning)	+/-0.10mm
Laser cutting accuracy (without repositioning)	+/-0.05mm
Machine dimensions (L x W x H)	5500mm x 5300mm x 2330mm
Machine weight	17500kg

If you need more product specification please contact with us.



**Deratech Industries**

Molenweg 101  
2830 Willebroek  
Belgium  
T: +32 (0)3 279 81 62  
F: +32 (0)3 279 81 63  
E: [bjorn@deratechindustries.com](mailto:bjorn@deratechindustries.com)  
W: [www.deratechgroup.com](http://www.deratechgroup.com)

**Deratech China**

N°. 398, Shuangzhu Rd Jiading  
District, Shanghai City  
P.R. China  
T: +86 (21) 3107 4898  
F: +86 (21) 3107 4897  
E: [info@deratech.cn](mailto:info@deratech.cn)  
W: [www.deratech.cn](http://www.deratech.cn)

**Deratech UAE**

Dubai UAE  
T: +971 50 41 20 357  
E: [samer@deratechindustries.com](mailto:samer@deratechindustries.com)  
W: [www.deratechgroup.com](http://www.deratechgroup.com)

**Deratech GmbH**

Königsallee 60F  
40212 Düsseldorf  
Germany  
T: +49211 88284 166  
F: +49211 88284 117  
E: [info@deratech.de](mailto:info@deratech.de)  
W: [www.deratech.de](http://www.deratech.de)

**Deratech Australia**

5/35-41 Westpool Drive  
Hallam - Victoria 3803  
Australia  
T: +613 9796 5260  
F: +613 9796 5360  
E: [sales@deratechgroup.com.au](mailto:sales@deratechgroup.com.au)  
W: [www.deratech.com.au](http://www.deratech.com.au)

**Deratech Thailand**

101/82 Moo 12 - Puttamonthon 5 Road  
Raijing Sampran - Nakhonpathom  
73210 Thailand  
T: +6624 088637-8  
F: +6624 088639  
E: [thailand@deratechgroup.com](mailto:thailand@deratechgroup.com)  
W: [www.deratechgroup.com](http://www.deratechgroup.com)

**Finval Industry**

14/22, 2-d Youzhnoportoviy Proezd  
115088 Moscow  
Russia  
T: +7 (495) 213 87 83  
F: +7 (495) 647 88 56  
E: [sales@deratechgroup.com](mailto:sales@deratechgroup.com)  
W: [www.finval.ru](http://www.finval.ru)

**Promech Engineering**

Nile Tower - Second floor office A1  
Corniche El-Nile Maadi - Cairo  
Egypt  
T: (662) 105 42 67  
F: (662) 482 19 84  
E: [sameh@promech-eg.com](mailto:sameh@promech-eg.com)  
W: [www.promech-eg.com](http://www.promech-eg.com)

**M/s Tech Mach Machine Tool**

#34 Basement - 1<sup>st</sup> main Road  
Anandnagar - Bangalore - 560024  
Karnataka State - India  
T: +91 080 23531 129  
F: +91 984 5068 437  
E: [sales@deratechgroup.com](mailto:sales@deratechgroup.com)  
W: [www.techmach.com](http://www.techmach.com)

**Deratech México**

Montecito 38, Piso 28, Ofic 12 y 13.  
Colonia Nápoles.  
Delegación Benito Juárez.  
México, D.F. 03810.  
T: +(55) 5547 4963  
E: [ventas@deratech.mx](mailto:ventas@deratech.mx)  
W: [www.deratechgroup.com](http://www.deratechgroup.com)

**Promotec LSMC Srl**

Via Levico, 25/A  
35035 Mestrino - Padova  
Italy  
T: +39 (049) 900 46 19  
E: [a.riva@gigant-industries.com](mailto:a.riva@gigant-industries.com)  
W: [www.gigant-industries.com](http://www.gigant-industries.com)

