

25TB

CARTON ERECTOR

- Shift with one click for different box sizes
- 48-72mm wide tape head
- 30 cartons per minute
- Fully automatic



SPECIFICATIONS

25TB

FEATURES

- Fully automatic, folds and seals bottom flaps
- Folds and seals up to 30 cartons per minute
- Easy-to-load tape head (can handle 48-72mm wide tapes)
- Can be used free-standing or in fully automatic in-line operation
- Right side in-feed direction (left side in-feed available)
- Shift with one-click for different box sizes
- Kraft paper or BOPP tapes
- Includes safety door

TECHNICAL

- Carton length: 260-480mm
- Carton width: 160-380mm
- Carton height: 160-380mm
- Table height: 690mm
- Total weight: 1000kg
- Air pressure required: 87psi
- Power supply: single phase / 220v / 50hz

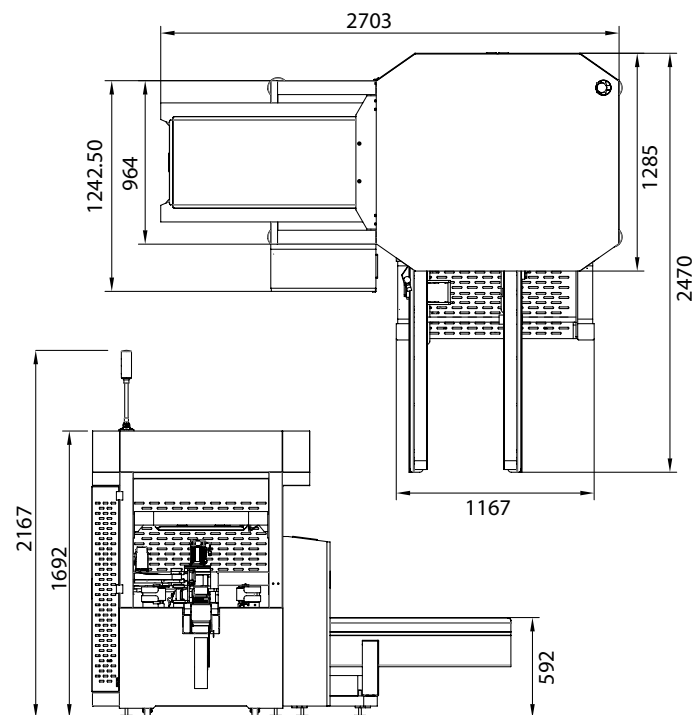

12-MONTH WARRANTY