



code:  
8370.USA10.20

SERVICE TROLLEYS  
Floor and Sugar Trolley

model:  
OZP-IBS-102



#### MAIN FEATURES

- Stores and transports a wide variety of dry ingredients such as flour, sugar, rice or grains. Perfect for restaurants, food manufacturers or commissaries.
- Available 102 capacity to meet standard industry requirements for storage and transportation of bulk foods.
- One-piece, seamless single-wall polyethylene bin construction is extremely durable. Rust or corrosion Resistant. Liquids and dry foods will not stick or seep between seams.
- Smooth interior and exterior are easy to clean.
- Special design of lid allows for easy drainage and quick drying while completely protecting contents. Spilled fluids drain off back lid.
- Working height permits storage under standard work tables.
- Heavy-duty castors, 2 front swivel, 2 fixed.
- No assembly required.

#### CONSTRUCTION

#### OPTIONS

#### ACCESSORIES

#### STANDARDS

- \* EN 60335-1 European Standard relating to safety of household and similar electrical appliances
- \* EN 60335-2-49 European Standard relating to particular requirements for commercial electric hot cupboards





**code:**  
8370.USA10.20

**SERVICE TROLLEYS**  
Floor and Sugar Trolley

**model:**  
OZP-IBS-102

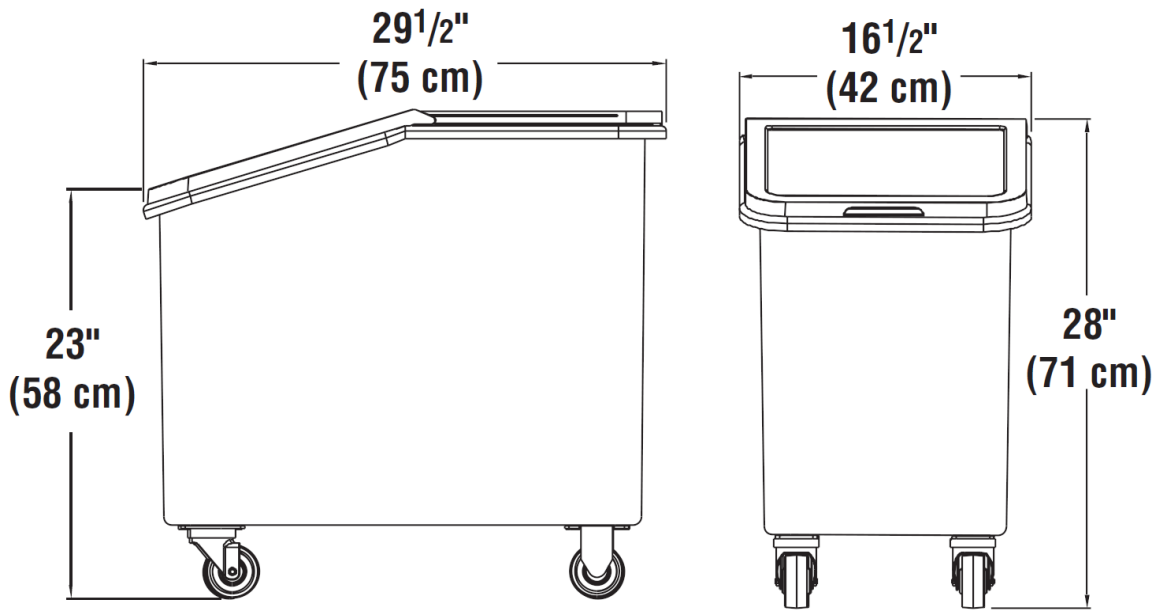

DIMENSIONS (Net)		DIMENSIONS (Shipping)	
* Width (mm)	420	* Width (mm)	
* Depth (mm)	750	* Depth (mm)	
* Height (mm)	710	* Height (mm)	
* Weight (kg)	35	* Weight (kg)	
		* Volume (m³)	

**TECHNICAL SPECIFICATIONS**

	<b>ELECTRICITY</b>
--	--------------------

	<b>WATER-IN</b>
--	-----------------

* Cold Water Inlet:	Pressure (min-max)	bar	kPa	Temperature (min-max)	°C
* Hot Water Inlet:					
* Hardness:	F				

	<b>DRAIN</b>
--	--------------

\*  
\*