



PEM® brand self-clinching studs and pins install permanently in aluminum, steel or stainless steel sheets.



FH™



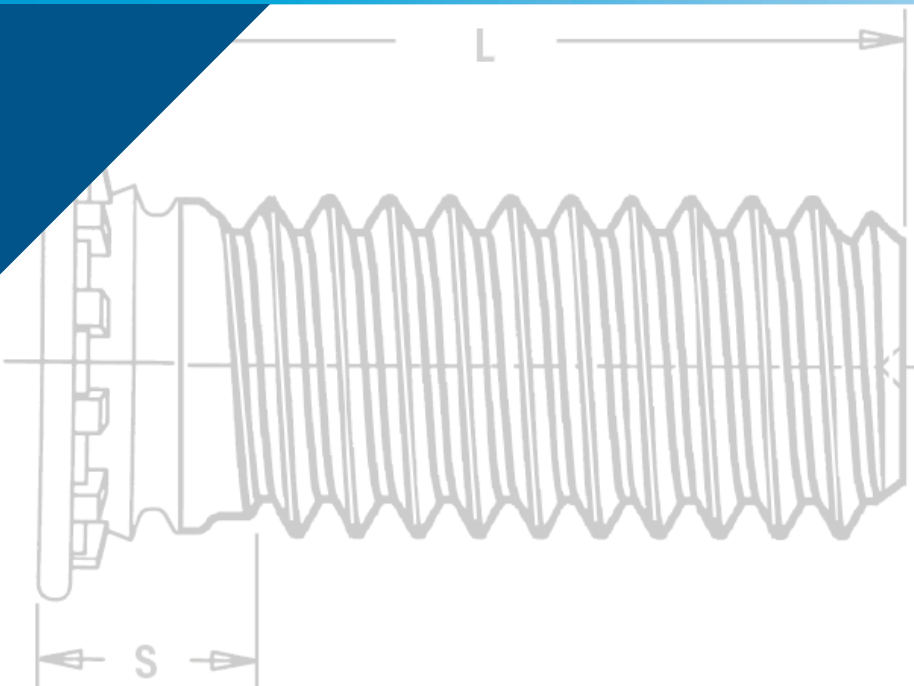











**SELF-CLINCHING
STUDS AND PINS**



SELF-CLINCHING STUDS AND PINS

PEM® self-clinching studs are easily installed by placing them in properly sized holes in sheets and squeezing into place with any standard press:

- Install permanently in aluminum, steel or stainless steel in sheets as thin as .020" / 0.51 mm.
- High torque-out and pushout resistances.

<p>Dog Point and Anti Cross-Thread Options - PAGE 4</p>		<p>HFE™/THFE™ (heavy-duty) studs Provides maximum pull through in sheets as thin as .031" / 0.8 mm - PAGE 10</p>	
<p>FH™/FHS™/FHA™ (flush-head) studs are available in aluminum, steel, or stainless steel - PAGE 5</p>		<p>HFG8™/HF109™ (heavy-duty high tensile strength) studs are manufactured for the most demanding applications from medium carbon alloy steel, then heat-treated to high strength and hardness qualities - PAGE 11</p>	
<p>FH4™/FHP™ (flush-head) studs are designed to provide strong threads in stainless steel sheets as thin as .040"/1 mm. FHP studs have high corrosion resistance - PAGE 6</p>		<p>HFLH™ studs are for installation into thin, harder, high-strength materials - PAGE 12</p>	
<p>FHL™/FHLs™ (flush, low-displacement head) studs have a smaller head diameter and install closer to the edge of a sheet than PEM FH/FHS studs - PAGE 7</p>		<p>SGPC™ swaging collar studs can install into most panel material and accommodate multiple panels as long as the total thickness does not exceed the maximum sheet thickness - PAGE 13</p>	
<p>TFH™/TFHS™ (non-flush) studs are for sheets as thin as .020" / 0.51 mm. The stud head will project above the sheet surface approximately .025"/0.64mm - PAGE 8</p>		<p>FHX™ flush-head studs with X-Press™ thread profile are typically used with push-on or other plastic fasteners - PAGE 14</p>	
<p>HFH™/HFHS™ (heavy-duty) studs have a large head which projects above the sheet material to distribute the axial tightening force over a large area thereby improving pull through resistance - PAGE 9</p>		<p>FH™/FHS™/FHA™ (flush-head) Pins are available on special order - PAGE 15</p>	
<p>HFHB™ (heavy-duty BUSBAR®) studs are ideal for applications which demand superior electrical/mechanical attachment points - PAGE 9</p>		<p>TPS™/TP4™/TPXS™ (flush-head) pilot pins satisfy a wide range of positioning, pivot, and alignment applications - PAGE 16</p>	
		<p>Material and finish specifications - PAGE 17</p>	
		<p>Installation - PAGES 18 - 25</p>	
		<p>Performance data - PAGES 26 - 32</p>	



Flush-head studs
Types FH/FHA/FHS/FHP/FH4



Flush, low-displacement head studs
Types FHL/FHLs



Thin sheet studs
Types TFH/TFHS

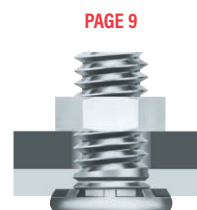

Heavy-duty studs
Types HFH/HFHS/HFHB



Heavy-duty studs for thin sheets
Types HFE/THFE

SELF-CLINCHING STUDS AND PINS

STUD SELECTOR GUIDE

PEM Stud Type	Application Requires:												
	Flush-head	Heavy duty	Grade 8/ Property Class 10.9 thread strength	Sheet thickness as thin as .020" / 0.51 mm	Superior electrical conductivity	Installation into stainless steel sheets	Compatibility with aluminum anodizing	Superior corrosion resistance	Closest centerline-to-edge distance	Unthreaded stud/pin	Large hole in attached Panel	Push on plastic fasteners	Max. panel hardness (2)
FH	▪												HRB 80 HB 150
FHA	▪						▪	▪					HRB 50 HB 82
FHS	▪							▪					HRB 70 HB 125
FH4	▪					▪							HRB 92 HB 195
FHP	▪					▪		▪					HRB 92 HB 195
FHL	▪								▪				HRB 80 HB 150
FHLS	▪							▪	▪				HRB 70 HB 125
TFH				▪									HRB 80 HB 150
TFHS				▪				▪					HRB 70 HB 125
HFH		▪ (1)									▪		HRB 85 HB 165
HFHB		▪			▪			▪			▪		HRB 55 HB 83
HFHS		▪						▪			▪		HRB 70 HB 125
HFE		▪									▪		HRB 85 HB 165
THFE		▪									▪		HRB 85 HB 165
HFG8/HF109		▪	▪								▪		HRB 89 HB 180
HFLH		▪									▪		HRB 96 HB 216
SGPC						▪			▪				Any sheet hardness
FHX	▪											▪	HRB 80 HB 150
FH Unthreaded	▪									▪			HRB 80 HB 150
FHA Unthreaded	▪						▪	▪		▪			HRB 50 HB 82
FHS Unthreaded	▪							▪		▪			HRB 70 HB 125
TPS	▪							▪		▪			HRB 70 HB 125
TP4	▪					▪				▪			HRB 92 HB 195
TPXS	▪							▪		▪			HRB 70 HB 125

(1) Meets grade 5 / property class 9.8 tensile requirements.

(2) HRB - Hardness Rockwell "B" Scale. HB - Hardness Brinell.

Standard product features shown above. Studs can also be custom designed to meet your exact application requirements.

PAGE 11

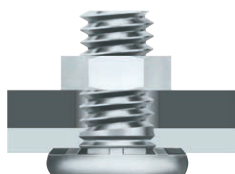

Heavy-duty, high tensile strength studs
Types HFG8/HF109

PAGE 12

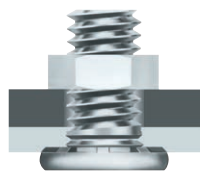

Studs for hard panels
Type HFLH

PAGE 13



Swaging collar studs
Type SGPC

PAGE 14

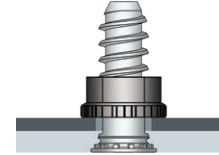

Flush-head Studs with
X-Press™ Thread Profile
Type FHX

PAGE 16



Flush-head pins
Types TPS/TP4



SELF-CLINCHING STUDS AND PINS

OPTIONAL DOG POINT FEATURE

PEM® dog point lead-in option for studs allows quick location of the mating fastener during assembly and protects the first thread of the stud during nut engagement. This feature is available on Types FH, FHL, HFH, HFE, HF109, HFG8, TFH and THFE studs.

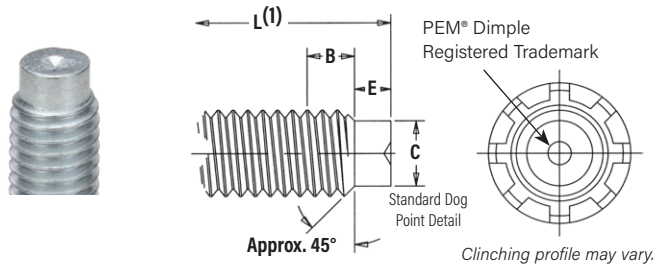

All dimensions are in inches.

All dimensions are in millimeters.

Unified Thread Size	C ±.005 (2)	E ±.010	B Nom. Transitional Length to Full Thread	Metric Thread Size	C ±0.13 (2)	E ±0.25	B nom. Transitional Length to Full Thread
.138-32 (#6-32)	.086	.050	.098	M3.5 x 0.6	2.4	1.27	1.88
.164-32 (#8-32)	.111	.055	.099	M4 x 0.7	2.79	1.4	2.26
.190-24 (#10-24)	.124	.065	.127	M5 x 0.8	3.66	1.78	2.48
.190-32 (#10-32)	.138	.065	.098	M6 x 1	4.37	2.03	3.05
.250-20 (1/4-20)	.173	.085	.149	M8 x 1.25	6.05	2.67	3.73
.250-28 (1/4-28)	.192	.085	.110	M10 x 1.5	7.72	3.43	4.37
.313-18 (5/16-18)	.228	.105	.164				
.313-24 (5/16-24)	.246	.105	.127				
.375-16 (3/8-16)	.282	.125	.182				
.375-24 (3/8-24)	.309	.125	.126				

OPTIONAL PART NUMBER DESIGNATION

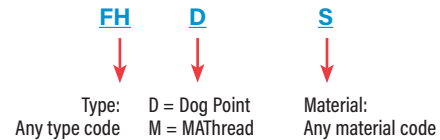

(1) For "L" refer to type stud lengths.

(2) Maximum dog point diameter is .003" / 0.08 mm less than minimum minor diameter of 2B or 6H nut threads.

OPTIONAL MATHread® ANTI CROSS-THREAD FEATURE

PennEngineering is a licensee of MATHread® Anti Cross-Threading Technology. This unique design allows the threads to self-align and drive easily with reduced effort. This helps speed assembly, reduce or eliminate failures, repairs, scrap, downtime, and warranty service associated with thread damage. This option is available on most types of PEM studs.



Anti Cross-Thread Feature

MATHread is a registered trademark of MATHread inc.

OPTIONAL POINTED STUD FEATURE

A pointed lead-in option for studs allows quick location of mating fastener during assembly to speed assembly and significantly reduces the likelihood of cross threading. Clip grooves for snap rings can also be added. This feature can be added to most types of PEM studs.

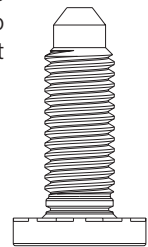

OPTIONAL THREAD MASK

PEM® Blu-Coat™ thread mask is available for applications where hardware is installed prior to painting. During assembly, the threads of the mating hardware will remove paint, electro deposited automotive under coatings, and weld spatter upon application of torque. PEM studs can be specially ordered with thread mask applied.

"BC" suffix will be added to part number to designate Blu-Coat thread mask to fastener.



AVAILABLE PEM® VARIMOUNT® FASTENING SYSTEM

The PEM® VariMount® fastening system (see PEM® Bulletin VM) utilizes a self-clinching stud paired with a round steel or stainless steel base plate to offer a clean and ready-made assembly for mounting into any rigid material or panel, including composites, plastics, and metals. Multiple radial holes in the base plate and a generous footprint provide effective mounting of the assembly. Mounting can be performed either on the front or through the back of a panel.



SELF-CLINCHING STUDS AND PINS

FH™/FHS™/FHA™ FLUSH-HEAD STUDS

- Flush-head for sheet thickness of .040" / 1 mm and greater.
- FH studs are recommended for use in steel or aluminum sheets HRB (Rockwell "B" scale) 80 / HB (Hardness Brinell) 150 or less.
- FHS studs are recommended for use in steel or aluminum sheets HRB (Rockwell "B" scale) 70 / HB (Hardness Brinell) 125 or less.
- FHA studs are recommended for use in aluminum sheets HRB (Rockwell "B" scale) 50 / HB (Hardness Brinell) 82 or less.

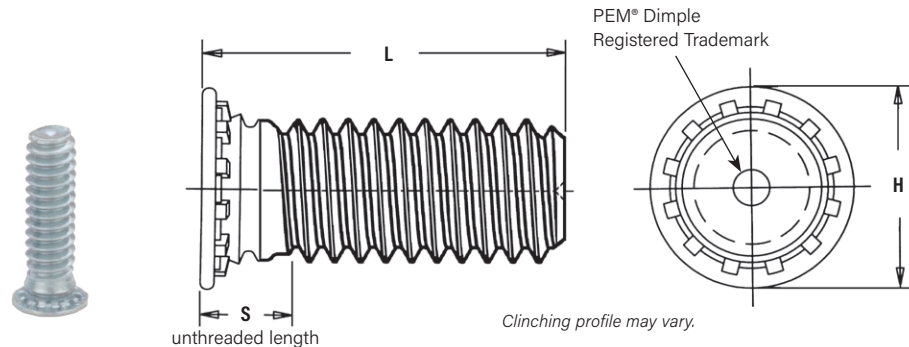

PART NUMBER DESIGNATION

FH	-	632	-	6	ZI
FH	S	-	632	-	6
FH	A	-	632	-	6
↓	↓	↓	↓	↓	↓
Type	Material Code	Thread Code	Length Code	Finish Code	

All dimensions are in inches.

UNIFIED	Thread Size	Type			Thread Code	Length Code "L" ±.015 (Length Code in 16ths of an inch)										Min. Sheet Thickness (1)	Hole Size in Sheet +.003 -.000	Max. Hole in Attach. Parts	H ± .015	S Max. (2)	Min. Dist. Hole to Edge
		Fastener Material				.250	.312	.375	.500	.625	.750	.875	1.00	1.25	1.50						
		Steel	Stainless Steel	Aluminum																	
.086-56 (#2-56)	FH	FHS	-	256	4	5	6	8	10	12	-	-	-	-	.040	.085	.105	.144	.075	.187	
.112-40 (#4-40)	FH	FHS	FHA	440	4	5	6	8	10	12	14	16	20	-	.040	.111	.135	.176	.085	.219	
.138-32 (#6-32)	FH	FHS	FHA	632	4	5	6	8	10	12	14	16	20	24	.040	.137	.160	.206	.090	.250	
.164-32 (#8-32)	FH	FHS	FHA	832	4	5	6	8	10	12	14	16	20	24	.040	.163	.185	.237	.090	.281	
.190-24 (#10-24)	FH	FHS	FHA	024	-	5	6	8	10	12	14	16	20	24	.040	.189	.210	.256	.100	.281	
.190-32 (#10-32)	FH	FHS	FHA	032	-	5	6	8	10	12	14	16	20	24	.040	.189	.210	.256	.100	.281	
.250-20 (1/4-20)	FH	FHS	FHA	0420	-	-	6	8	10	12	14	16	20	24	.062	.249	.270	.337	.135	.312	
.313-18 (5/16-18)	FH	FHS	-	0518	-	-	-	8	10	12	14	16	20	24	.093	.311	.333	.376	.160	.375	

All dimensions are in millimeters.

METRIC	Thread Size x Pitch	Type			Thread Code	Length Code "L" ±0.4 (Length Code in millimeters)										Min. Sheet Thickness (1)	Hole Size in Sheet +0.08	Max. Hole in Attach. Parts	H ± 0.4	S Max. (2)	Min. Dist. Hole to Edge
		Fastener Material				6	8	10	12	15	18	20	25	30	35						
		Steel	Stainless Steel	Aluminum																	
M2.5 x 0.45	FH	FHS	FHA	M2.5	6	8	10	12	15	18	-	-	-	-	1	2.5	3.1	4.1	1.95	5.4	
M3 x 0.5	FH	FHS	FHA	M3	6	8	10	12	15	18	20	25	-	-	1	3	3.6	4.6	2.1	5.6	
M3.5 x 0.6	FH	FHS	FHA	M3.5	6	8	10	12	15	18	20	25	30	-	1	3.5	4.1	5.3	2.25	6.4	
M4 x 0.7	FH	FHS	FHA	M4	6	8	10	12	15	18	20	25	30	35	1	4	4.6	5.9	2.4	7.2	
M5 x 0.8	FH	FHS	FHA	M5	-	8	10	12	15	18	20	25	30	35	1	5	5.6	6.5	2.7	7.2	
M6 x 1	FH	FHS	FHA	M6	-	-	10	12	15	18	20	25	30	35	1.6	6	6.6	8.2	3	7.9	
M8 x 1.25	FH	FHS	-	M8	-	-	-	12	15	18	20	25	30	35	2.4	8	8.6	9.6	3.7	9.6	

(1) See page 18 for installation tool requirements.

(2) Threads are gaugeable to within 2 pitches of the "S" Max. dimension. A class 3B/5H maximum material commercial nut shall pass up to the "S" Max. dimension.



SELF-CLINCHING STUDS AND PINS

FH4™/FHP™ FLUSH-HEAD STUDS FOR STAINLESS STEEL SHEETS

- Recommended for use in stainless steel sheets HRB (Rockwell "B" Scale) 92 / HB (Hardness Brinell) 195 or less.
- FHP studs offer optimum corrosion resistance and are ideal for medical, foodservice, and marine applications.

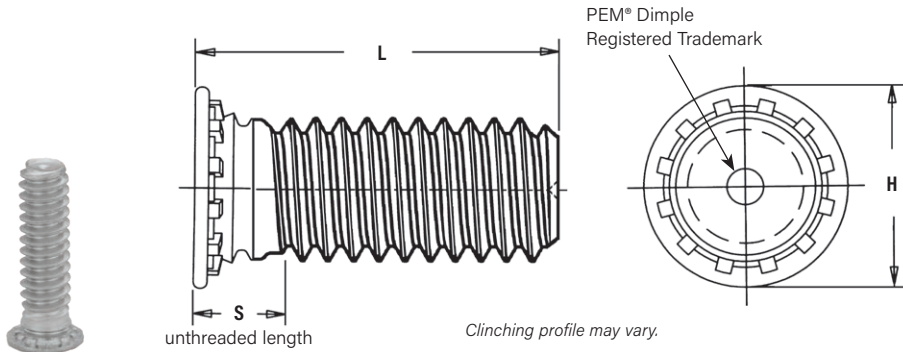

PART NUMBER DESIGNATION

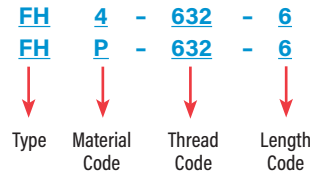

All dimensions are in inches.

UNIFIED	Thread Size	Type		Thread Code	Length Code "L" ±.015 (Length code in 16ths of an inch)									Sheet Thickness (2)	Hole Size in Sheet +.003 -.000	Max. Hole in Attach. Parts	H ±.015	S Max. (3)	Min. Dist. Hole \varnothing to Edge	
		Fastener Material			.250	.312	.375	.500	.625	.750	.875	1.00	1.25							1.50
		Stainless Steel (1)																		
.112-40 (#4-40)	FH4	FHP	440	4	5	6	8	10	12	14	16	—	—	.040-.095	.111	.131	.176	.085	.219	
.138-32 (#6-32)	FH4	FHP	632	4	5	6	8	10	12	14	16	20	24	.040-.095	.137	.157	.206	.090	.250	
.164-32 (#8-32)	FH4	FHP	832	4	5	6	8	10	12	14	16	20	24	.040-.095	.163	.183	.237	.090	.281	
.190-32 (#10-32)	FH4	FHP	032	—	5	6	8	10	12	14	16	20	24	.040-.095	.189	.209	.256	.100	.281	
.250-20 (1/4-20)	FH4	—	0420	—	—	6	8	10	12	14	16	20	24	.062-.117	.249	.269	.337	.135	.312	

All dimensions are in millimeters.

METRIC	Thread Size x Pitch	Type		Thread Code	Length Code "L" ±0.4 (Length Code in millimeters)									Sheet Thickness (2)	Hole Size in Sheet +0.08	Max. Hole in Attach. parts	H ±0.4	S Max. (3)	Min. Dist. Hole \varnothing to Edge	
		Fastener Material			6	8	10	12	15	18	20	25	30							35
		Stainless Steel (1)																		
M3 x 0.5	FH4	FHP	M3	6	8	10	12	15	18	20	25	—	—	1 - 2.4	3	3.3	4.6	2.1	5.6	
M4 x 0.7	FH4	FHP	M4	6	8	10	12	15	18	20	25	30	35	1 - 2.4	4	4.7	5.9	2.4	7.2	
M5 x 0.8	FH4	FHP	M5	—	8	10	12	15	18	20	25	30	35	1 - 2.4	5	5.3	6.5	2.7	7.2	
M6 x 1	FH4	—	M6	—	—	10	12	15	18	20	25	30	35	1.6 - 3	6	6.8	8.2	3	7.9	

(1) See material and finish specifications chart on page 17 for details.

(2) Performance may be reduced for studs installed into thicker sheets.

(3) Threads are gaugeable to within 2 pitches of the "S" Max. dimension. A class 3B/5H maximum material commercial nut shall pass up to the "S" Max. dimension.

A NOTE ABOUT 400 SERIES FASTENERS FOR STAINLESS STEEL PANELS

In order for self-clinching fasteners to work properly, the fastener must be harder than the sheet into which it is being installed. In the case of stainless steel panels, fasteners made from 300 Series Stainless Steel do not meet this hardness criteria. It is for this reason that 400 series fasteners are offered (Types FH4 and TP4). However, while these 400 Series fasteners install and perform well in 300 Series stainless sheets they should not be used if the end product:

- Will be exposed to any appreciable corrosive presence.
- Requires non-magnetic fasteners.
- Will be exposed to any temperatures above 300°F (149°C)

If any of these are issues, please contact techsupport@pemnet.com for other options such as the FHP™ stud, made from precipitation hardened grade stainless steel which is not subject to these issues.



SELF-CLINCHING STUDS AND PINS

FHL™/FHLS™ FLUSH, LOW-DISPLACEMENT HEAD STUDS

- Installs closer to the edge of a sheet than PEM Type FH/FHS studs without causing that edge to bulge.
- Flush-head for sheet thickness .040" / 1 mm and greater.
- FHL studs are recommended for use in steel or aluminum sheets HRB (Rockwell "B" Scale) 80 / HB (Hardness Brinell) 150 or less.
- FHLS studs are recommended for use in steel or aluminum sheets HRB (Rockwell "B" Scale) 70 / HB (Hardness Brinell) 125 or less.

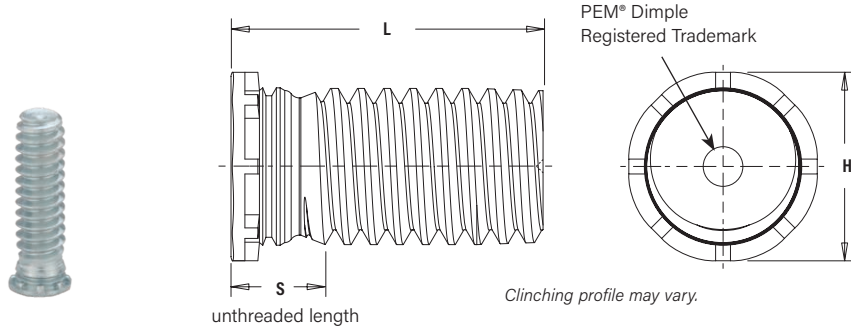

PART NUMBER DESIGNATION

FHL - **632** - **6** **ZI**
FHL S - **632** - **6**

↓ Type ↓ Material Code ↓ Thread Code ↓ Length Code ↓ Finish Code

All dimensions are in inches.

UNIFIED	Thread Size	Type		Thread Code	Length Code "L" ±.015 (Length Code in 16ths of an inch)										Min. Sheet Thickness (I)	Hole Size in Sheet +.003 - .000	Max. Hole in Attach. Parts	H ±.015	S Max. (2)	Min. Dist. Hole ϕ to Edge
		Fastener Material																		
		Steel	Stainless Steel																	
.086-56 (#2-56)	FHL	FHLS	256	4	5	6	8	10	12	—	—	—	—	.040	.085	.100	.112	.080	.098	
.112-40 (#4-40)	FHL	FHLS	440	4	5	6	8	10	12	14	16	—	—	.040	.111	.126	.138	.085	.124	
.138-32 (#6-32)	FHL	FHLS	632	4	5	6	8	10	12	14	16	20	24	.040	.137	.152	.164	.090	.150	
.164-32 (#8-32)	FHL	FHLS	832	4	5	6	8	10	12	14	16	20	24	.040	.163	.178	.190	.090	.176	
.190-32 (#10-32)	FHL	FHLS	032	—	5	6	8	10	12	14	16	20	24	.040	.189	.204	.225	.100	.210	

All dimensions are in millimeters.

METRIC	Thread Size x Pitch	Type		Thread Code	Length Code "L" ±0.4 (Length Code in millimeters)										Min. Sheet Thickness (I)	Hole Size in Sheet +0.08	Max. Hole in Attach. Parts	H ±0.4	S Max. (2)	Min. Dist. Hole ϕ to Edge
		Fastener Material																		
		Steel	Stainless Steel																	
M2.5 x 0.45	FHL	FHLS	M2.5	6	8	10	12	15	18	—	—	—	—	1	2.5	2.9	3.15	2.1	2.8	
M3 x 0.5	FHL	FHLS	M3	6	8	10	12	15	18	20	25	—	—	1	3	3.2	3.65	2.1	3.3	
M3.5 x 0.6	FHL	FHLS	M3.5	6	8	10	12	15	18	20	25	30	—	1	3.5	3.9	4.15	2.3	3.8	
M4 x 0.7	FHL	FHLS	M4	6	8	10	12	15	18	20	25	30	35	1	4	4.5	4.65	2.4	4.3	
M5 x 0.8	FHL	FHLS	M5	—	8	10	12	15	18	20	25	30	35	1	5	5.2	5.9	2.7	5.6	

- See page 19 for installation tool requirements.
- Threads are gaugeable to within 2 pitches of the "S" Max. dimension. A class 3B/5H maximum material commercial nut shall pass up to the "S" Max. dimension.

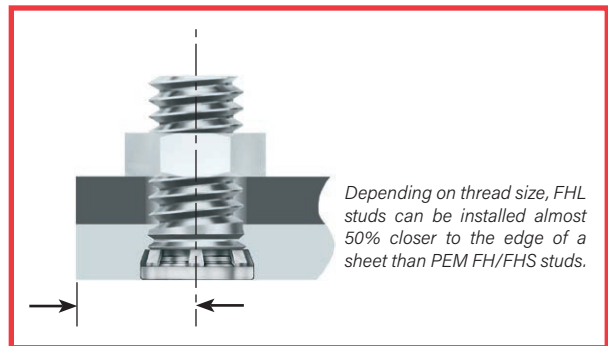

SELF-CLINCHING STUDS AND PINS

TFH™/TFHS™ NON-FLUSH STUDS

- Non-flush for sheets as thin as .020" / 0.51 mm.
- TFH studs are recommended for use in steel or aluminum sheets HRB (Rockwell "B" Scale) 80 / HB (Hardness Brinell) 150 or less.
- TFHS studs are recommended for use in steel or aluminum sheets HRB (Rockwell "B" Scale) 70 / HB (Hardness Brinell) 125 or less.

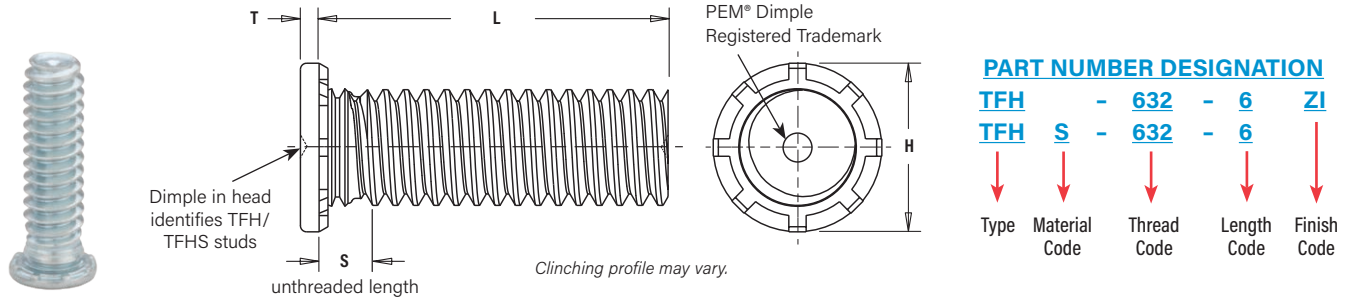

All dimensions are in inches.

UNIFIED	Thread Size	Type		Thread Code	Length Code "L" ±.015 (Length Code in 16ths of an inch)									Min. Sheet Thickness (1)	Hole Size in Sheet +.003 -.000	Max. Hole in Attach. Parts	H ±.015	S Max. (2)	T Max.	Min. Dist. Hole to Edge	
		Steel	Stainless Steel		.250	.312	.375	.500	.625	.750	.875	1.00	1.25								1.50
.086-56 (#2-56)	TFH	TFHS	256	4	5	6	8	10	12	—	—	—	—	.020	.085	.105	.141	.070	.025	.187	
.112-40 (#4-40)	TFH	TFHS	440	4	5	6	8	10	12	14	—	—	—	.020	.111	.131	.176	.070	.025	.219	
.138-32 (#6-32)	TFH	TFHS	632	4	5	6	8	10	12	14	16	20	24	.020	.137	.157	.203	.070	.025	.250	
.164-32 (#8-32)	TFH	TFHS	832	4	5	6	8	10	12	14	16	20	24	.020	.163	.183	.234	.070	.025	.281	
.190-24 (#10-24)	TFH	TFHS	024	—	5	6	8	10	12	14	16	20	24	.020	.189	.209	.250	.090	.025	.281	
.190-32 (#10-32)	TFH	TFHS	032	—	5	6	8	10	12	14	16	20	24	.020	.189	.209	.250	.090	.025	.281	

All dimensions are in millimeters.

METRIC	Thread Size x Pitch	Type		Thread Code	Length Code "L" ±0.4 (Length Code in millimeters)									Min. Sheet Thickness (1)	Hole Size in Sheet +0.08	Max. Hole in Attach. Parts	H ±0.4	S Max. (2)	T Max.	Min. Dist. Hole to Edge	
		Steel	Stainless Steel		6	8	10	12	15	18	20	25	—								—
M3 x 0.5	TFH	TFHS	M3	6	8	10	12	15	18	20	25	—	—	0.51	3	3.3	4.5	1.8	0.64	5.6	
M4 x 0.7	TFH	TFHS	M4	—	8	10	12	15	18	20	25	30	35	0.51	4	4.7	5.8	1.8	0.64	7.2	
M5 x 0.8	TFH	TFHS	M5	—	8	10	12	15	18	20	25	30	35	0.51	5	5.3	6.4	2.3	0.64	7.2	

(1) See page 20 for installation tool requirements.

(2) Threads are gaugeable to within 2 pitches of the "S" Max. dimension. A class 3B/5H maximum material commercial nut shall pass up to the "S" Max. dimension.



SELF-CLINCHING STUDS AND PINS

HFH™/HFHS™/HFHB™ HEAVY-DUTY STUDS

- HFH studs are for high-strength applications in sheets as thin as .050" / 1.3 mm.
- HFHS studs offer high corrosion resistance.
- HFHB studs are for superior electrical/mechanical attachment in copper.
- HFH studs are recommended for use in steel or aluminum sheets HRB (Rockwell "B" Scale) 85 / HB (Hardness Brinell) 165 or less.
- HFHS studs are recommended for use in steel or aluminum sheets HRB (Rockwell "B" Scale) 70 / HB (Hardness Brinell) 125 or less.
- HFHB studs are recommended for use in copper sheets HRB (Rockwell "B" Scale) 55 / HB (Hardness Brinell) 83 or less.

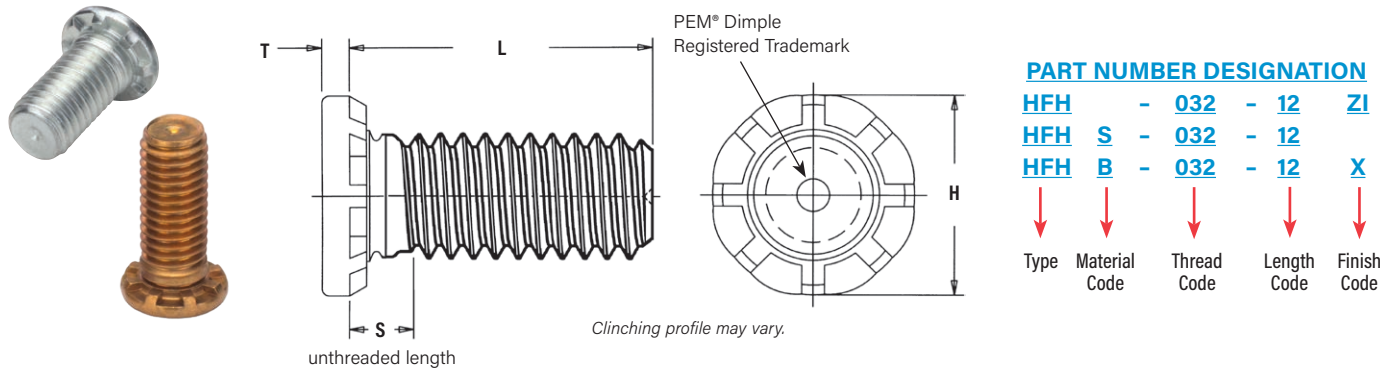

All dimensions are in inches.

UNIFIED	Thread Size	Type			Thread Code	Length Code "L" ±.015 (Length Code in 16ths of an inch)						Min. Sheet Thickness	Hole Size in Sheet +.005 -.000	Max. Hole in Attach. Parts	H ±.01	S Max. (2)	T Max.	Min. Dist. Hole ⌀ to Edge	
		Fastener Material				.500	.750	1.00	1.25	1.50	1.75								2.00
		Steel	Stainless Steel	Phosphor Bronze (1)															
	.190-32 (#10-32)	HFH	HFHS	HFHB	032	8	12	16	20	24	28	32	.050	.190	.252	.300	.105	.040	.415
	.250-20 (1/4-20)	HFH	HFHS	HFHB	0420	8	12	16	20	24	28	32	.060	.250	.312	.380	.125	.050	.460
	.313-18 (5/16-18)	HFH	HFHS	HFHB	0518	8	12	16	20	24	28	32	.075	.312	.374	.480	.140	.070	.500
	.375-16 (3/8-16)	HFH	HFHS	HFHB	0616	-	12	16	20	24	28	32	.090	.375	.437	.580	.155	.085	.530

Tensile strength: HFH - 120 ksi / HFHS - 75 ksi / HFHB - 60 ksi.

All dimensions are in millimeters.

METRIC	Thread Size x Pitch	Type			Thread Code	Length code "L" ±0.4 (Length Code in millimeters)						Min. Sheet Thickness	Hole Size in Sheet +0.13	Max. Hole in Attach. Parts	H ±0.25	S Max. (2)	T Max.	Min. Dist. Hole ⌀ to Edge	
		Fastener Material				15	20	25	30	35	40								50
		Steel	Stainless Steel	Phosphor Bronze(1)															
	M5 x 0.8	HFH	HFHS	HFHB	M5	15	20	25	30	35	40	50	1.3	5	6.4	7.8	2.7	1.14	10.7
	M6 x 1	HFH	HFHS	HFHB	M6	15	20	25	30	35	40	50	1.5	6	7.5	9.4	2.8	1.27	11.5
	M8 x 1.25	HFH	HFHS	HFHB	M8	15	20	25	30	35	40	50	2	8	9.5	12.5	3.5	1.78	12.7
	M10 x 1.5	HFH	HFHS	HFHB	M10	15	20	25	30	35	40	50	2.3	10	11.5	15.7	4.1	2.29	13.7

Tensile strength: HFH - 900 MPa / HFHS - 515 MPa / HFHB - 415 MPa.

- The electrical resistance (tested at 10 amps DC) between phosphor bronze studs and copper busbars is below 104μ ohms and 62μ ohms for the #10-32 / M5 and 3/8-16 / M10 thread sizes respectively, after repeated thermal and mechanical cycling. For complete electrical resistance test data for type HFHB studs installed in copper, see bulletin entitled "Electrical Resistance of HFHB Studs Installed in Copper" on our website.
- Threads are gaugeable to within 2 pitches of the "S" Max. dimension. A class 3B/5H maximum material commercial nut shall pass up to the "S" Max. dimension.



SELF-CLINCHING STUDS AND PINS

HFE™/THFE™ HEAVY DUTY STUDS FOR THIN SHEETS

- Enlarged head diameter reduces stress on panel.
- Thicker head allows for larger hole in attached panels.
- Clinch design provides high-strength in sheets as thin as .031" / 0.8 mm.
- Recommended for use in steel or aluminum sheets HRB (Rockwell "B" Scale) 85 / HB (Hardness Brinell) 165 or less.

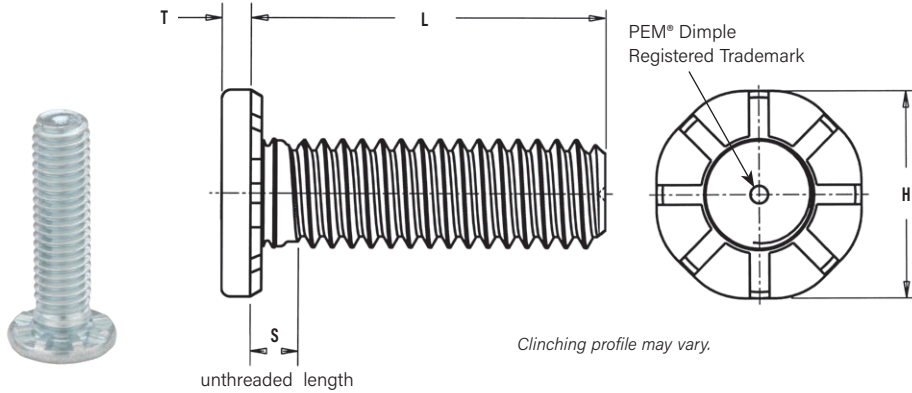

PART NUMBER DESIGNATION

HFE - 0420 - 12 ZI
 THFE - 0420 - 12 ZI

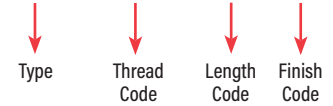

All dimensions are in inches.

UNIFIED	Thread Size	Type	Thread Code	Length Code "L" ±.015 (Length Code in 16ths of an inch)						Min. Sheet Thickness (1)	Hole Size In Sheet +.005 -.000	Max. Hole In Attached Parts	H ±.01	S Max. (2)	T Max.	Min. Dist. Hole To Edge	
		Fastener Material		.500	.750	1.00	1.25	1.50	1.75								2.00
		Steel															
.190-32 (#10-32)	HFE	032	8	12	16	20	24	28	32	.040	.190	.280	.357	.102	.048	.360	
	THFE																
.250-20 (1/4-20)	HFE	0420	8	12	16	20	24	28	32	.040	.250	.340	.462	.118	.060	.470	
	THFE									.031							.109
.313-18 (5/16-18)	HFE	0518	8	12	16	20	24	28	32	.060	.312	.402	.586	.133	.083	.560	
	THFE									.031							.117

Tensile strength: 120 ksi

All dimensions are in millimeters.

METRIC	Thread Size x Pitch	Type	Thread Code	Length Code "L" ±0.4 (Length Code in millimeters)						Min. Sheet Thickness (1)	Hole Size In Sheet +0.13	Max. Hole In Attached Parts	H ±0.25	S Max. (2)	T Max.	Min. Dist. Hole To Edge	
		Fastener Material		15	20	25	30	35	40								50
		Steel															
M5 x 0.8	HFE	M5	15	20	25	30	35	40	50	1	5	7.3	9.6	2.6	1.35	10	
	THFE																
M6 x 1	HFE	M6	15	20	25	30	35	40	50	1	6	8.3	11.35	2.8	1.52	11.5	
	THFE									0.8							2.62
M8 x 1.25	HFE	M8	15	20	25	30	35	40	50	1.5	8	10.3	15.3	3.3	2.13	14.5	
	THFE									0.8							2.9

Tensile strength: 900 MPa

(1) See page 21 for installation tool requirements.

(2) Threads are gaugeable to within 2 pitches of the "S" Max. dimension. A class 3B/5H maximum material commercial nut shall pass up to the "S" Max. dimension.



SELF-CLINCHING STUDS AND PINS

HFG8™/HF109™ HEAVY DUTY, HIGH TENSILE STRENGTH STUDS

- HFG8 and HF109 studs are for heavy-duty applications in sheets as thin as .040" / 1 mm.
- Grade 8 and property class 10.9 studs meeting 150 ksi/1040 MPa minimum.
- Recommended for use in steel or HSLA steel sheets HRB (Rockwell "B" Scale) 89 / HB (Hardness Brinell) 180 or less.
- Large head diameter spreads compressive stress on panel.

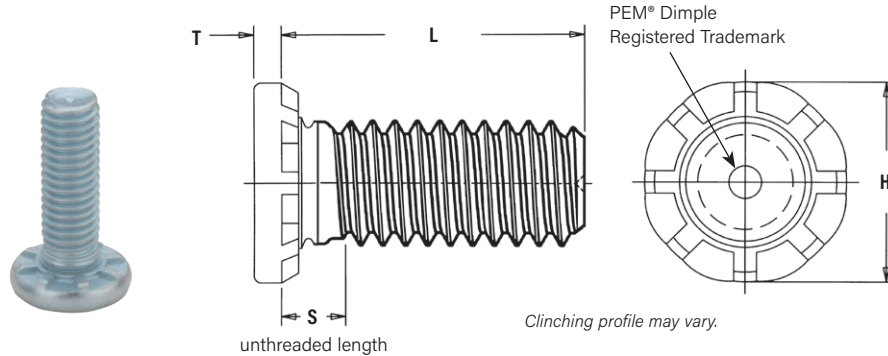

PART NUMBER DESIGNATION

HF	G8	- 0420	- 12	ZI
HF	109	- M6	- 20	ZI
↓	↓	↓	↓	↓
Type	Strength Code	Thread Code	Length Code	Finish Code

All dimensions are in inches.

UNIFIED	Thread Size	Type	Thread Code	Length Code "L" ±.015 ⁽¹⁾ (Length Code in 16ths of an inch)			Min. Sheet Thickness	Hole Size in Sheet +.005 -.000	Max. Hole in Attached Parts	H ±.01	S Max. (2)	T Max.	Min. Dist. Hole C/L To Edge
		Steel		.500	.750	1.00							
	.190-32 (#10-32)	HFG8	032	8	12	16	.040	.190	.280	.391	.105	.077	.469
.250-20 (1/4-20)	HFG8	0420	8	12	16	.040	.250	.340	.507	.125	.090	.709	
.313-18 (5/16-18)	HFG8	0518	—	12	16	.060	.312	.402	.645	.140	.126	.827	

Tensile strength: 150 ksi

All dimensions are in millimeters.

METRIC	Thread Size x Pitch	Type	Thread Code	Length Code "L" ±0.4 ⁽¹⁾ (Length Code in millimeters)			Min. Sheet Thickness	Hole Size in Sheet +0.13	Max. Hole in Attached Parts	H ±0.25	S Max. (2)	T Max.	Min. Dist. Hole C/L To Edge
		Steel		15	20	25							
M5 x 0.8	HF109	M5	15	20	25	1	5	7.3	10.3	2.6	2.06	11.5	
M6 x 1	HF109	M6	15	20	25	1	6	8.3	12.1	2.7	2.29	18.0	
M8 x 1.25	HF109	M8	—	20	25	1.5	8	10.3	16.6	3.4	3.25	21.0	

Tensile strength: 1040 MPa

- (1) Other lengths available up to a maximum of 1.5" (unified) and 40 mm (metric) on special order.
- (2) Threads are gaugeable to within 2 pitches of the "S" Max. dimension. A class 3B/5H maximum material commercial nut shall pass up to the "S" Max. dimension.

To be sure that you are getting genuine PEM products, look for the PEM stamp. Studs within the size range of the SAE and ISO specs are also identified with the Grade 8 and 10.9 head markings respectively.

HFG8 Marking*

* Thread size #10-32 does not have SAE head marking since it is technically not within the size range of the specification.



SELF-CLINCHING STUDS AND PINS

HFLH™ HARD PANEL STUDS

- Installs into thinner, harder, high strength steel materials
- Recommended for use in s500 HSLA sheets up to 700MPa (hardness up to 96 HRB)

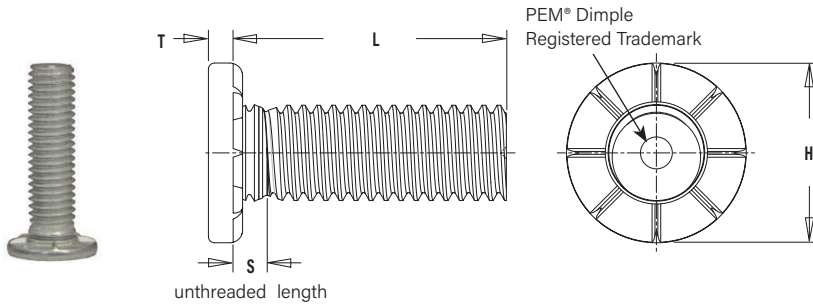

PART NUMBER DESIGNATION

HFLH - 0420 - 20 ZI

↓ ↓ ↓ ↓

Type Thread Code Length Code Finish Code

All dimensions are in inches.

UNIFIED	Thread Size	Type	Thread Code	Length Code "L" ±.015 (Length Code in 16ths of an inch)						Min. Sheet Thickness (1)	Hole Size In Sheet +.005 -.000	Max. Hole In Attached Parts	H ±.01	S Max. (2)	T Max.	Min. Dist. Hole To Edge	
		Fastener Material		.500	.750	1.00	1.25	1.50	1.75								2.00
		Hardened Alloy Steel															
	.190-32 (#10-32)	HFLH	032	8	12	16	20	24	28	32	.040	.190	.280	.357	.102	.048	.360
	.250-20 (1/4-20)	HFLH	0420	8	12	16	20	24	28	32	.040	.250	.340	.462	.118	.060	.470
	.313-18 (5/16-18)	HFLH	0518	8	12	16	20	24	28	32	.060	.312	.402	.586	.133	.083	.560

Tensile strength: 120 ksi

All dimensions are in millimeters.

METRIC	Thread Size x Pitch	Type	Thread Code	Length Code "L" ±.04 (Length Code in millimeters)						Min. Sheet Thickness (1)	Hole Size In Sheet +0.13	Max. Hole In Attached Parts	H ±0.25	S Max. (2)	T Max.	Min. Dist. Hole To Edge	
		Fastener Material		15	20	25	30	35	40								50
		Hardened Alloy Steel															
	M5 x 0.8	HFLH	M5	15	20	25	30	35	40	50	1	5	7.3	9.6	2.6	1.35	10
	M6 x 1	HFLH	M6	15	20	25	30	35	40	50	1	6	8.3	11.35	2.8	1.52	11.5
	M8 x 1.25	HFLH	M8	15	20	25	30	35	40	50	1.5	8	10.3	15.3	3.3	2.13	14.5

Tensile strength: 900 MPa

- See page 21 for installation tool requirements.
- Threads are gaugeable to within 2 pitches of the "S" Max. dimension. A class 3B/5H maximum material commercial nut shall pass up to the "S" Max. dimension.
- See PEM Technical Support section of our web site (www.pemnet.com) for related plating standards and specifications.
- "X" suffix studs may have pitch diameters and major diameters below 2A "Basic", per ANSI B1.1, Section 7, and B1.13M, Section 8 to allow for minimum of 0.0002" / 0.0051 mm of plating.



SELF-CLINCHING STUDS AND PINS

SGPC™ SWAGING COLLAR STUDS

- Installs into sheets as thin as .024" / 0.6 mm.
- Can be used to attach dissimilar materials.
- Can accommodate multiple panels as long as the total thickness does not exceed the maximum sheet thickness.⁽¹⁾
- Can be installed into most materials, including stainless steel and rigid non-metallic panels.
- Allows for close centerline-to-edge distance.

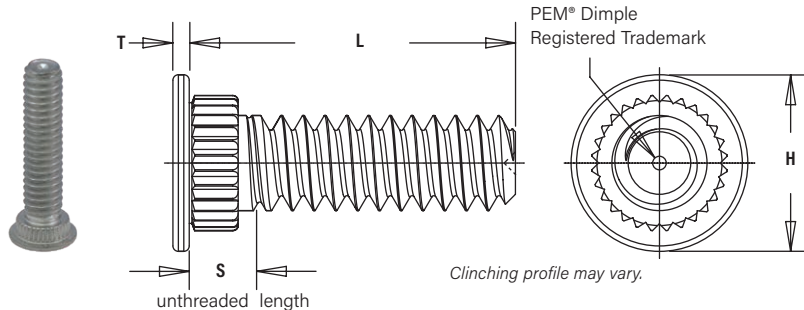

PART NUMBER DESIGNATION

SGPC - 632 - 8

↓ ↓ ↓

Type Thread Code Length Code

All dimensions are in inches.

UNIFIED	Thread Size	Type	Thread Code	Length Code "L" ±.015 (Length Code in 16ths of an inch)								Sheet Thickness (2)	Hole Size in Sheet +.003 -.000	Hole Dia. of Attached Panel +.005 -.000	H ±.010	S Max. (3)	T ±.004	Min. Dist. Hole to Edge	
		Fastener Material		.312	.375	.500	.625	.750	.875	1.00	1.25								1.50
		Stainless Steel																	
	.086-56 (#2-56)	SGPC	256	5	6	8	10	12	—	—	—	—	.024 - .047	.145	.182	.189	.093	.020	.130
	.112-40 (#4-40)	SGPC	440	5	6	8	10	12	14	16	20	—	.024 - .047	.171	.205	.228	.101	.024	.160
	.138-32 (#6-32)	SGPC	632	5	6	8	10	12	14	16	20	24	.024 - .047	.196	.229	.256	.109	.024	.180
	.164-32 (#8-32)	SGPC	832	5	6	8	10	12	14	16	20	24	.024 - .047	.223	.259	.279	.109	.024	.200
	.190-32 (#10-32)	SGPC	032	5	6	8	10	12	14	16	20	24	.024 - .047	.249	.280	.307	.109	.024	.210
	.250-20 (1/4-20)	SGPC	0420	—	6	8	10	12	14	16	20	24	.024 - .047	.309	.343	.366	.131	.028	.250

All dimensions are in millimeters.

METRIC	Thread Size x Pitch	Type	Thread Code	Length Code "L" ±0.4 (Length Code in millimeters)								Sheet Thickness (2)	Hole Size in Sheet +0.08	Hole Dia. of Attached Panel +0.13	H ±0.25	S Max. (3)	T ±0.1	Min. Dist. Hole to Edge	
		Fastener Material		8	10	12	15	18	—	—	—								—
		Stainless Steel																	
	M2.5 x 0.45	SGPC	M2.5	8	10	12	15	18	—	—	—	—	0.6 - 1.2	4	4.95	5	2.4	0.5	3.9
	M3 x 0.5	SGPC	M3	8	10	12	15	18	20	25	—	—	0.6 - 1.2	4.5	5.45	6	2.5	0.6	4.3
	M4 x 0.7	SGPC	M4	8	10	12	15	18	20	25	30	—	0.6 - 1.2	5.5	6.3	7	2.7	0.6	4.9
	M5 x 0.8	SGPC	M5	8	10	12	15	18	20	25	30	35	0.6 - 1.2	6.5	7.45	8	2.8	0.6	5.5
	M6 x 1	SGPC	M6	—	10	12	15	18	20	25	30	35	0.6 - 1.2	7.5	8.3	9	3	0.7	6.2

- (1) When using the fastener to attach more than one sheet or panel, the stud may seem slightly loose after installation. This is a normal condition in some applications and will not effect the stud's performance.
- (2) See page 23 for installation tooling requirements. Contact Technical Support (techsupport@pemnet.com) for other thicknesses.
- (3) Threads are gaugeable to within 2 pitches on the "S" Max. dimension. A class 3B/5H maximum material commercial nut shall pass up to the "S" Max. dimension.



SELF-CLINCHING STUDS AND PINS

FHX™ FLUSH-HEAD STUDS WITH X-PRESS™ THREAD PROFILE FOR USE WITH PUSH ON PLASTIC MATING FASTENERS

- Offers fast, reliable attachment.
- Coarse thread design of the thread reduces assembly time and provides high retention force.
- Allows for lighter assembly.
- Self-clinching stud mounts flush in metal sheets as thin as 1mm.
- Thread design accommodates paints and coatings without compromising performance.
- Self-clinching technology is cleaner and has a more attractive finished appearance than welding.
- Can be installed during the stamping process with PEMSERTER® in-die technology.

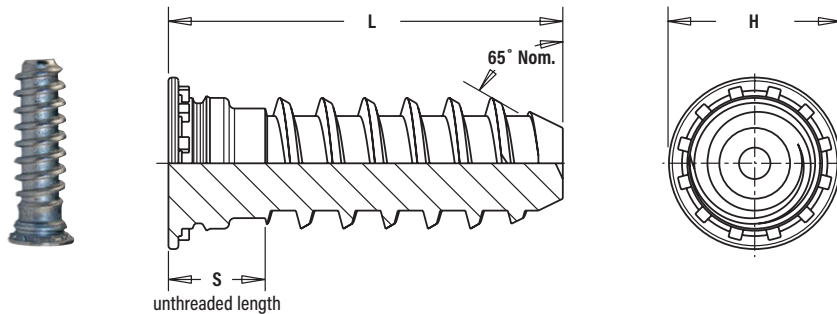

PART NUMBER DESIGNATION

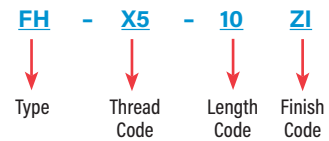

All dimensions are in millimeters.

Thread Size x Pitch	Type	Thread Code	Length Code "L" ±0.4 (Length Code in millimeters)				Min. Sheet Thickness	Hole Size in Sheet +0.08	H ±0.4	S Max.
			10	15	20	25				
5 mm x 1.6	FH	X5	10	15	20	25	1	5.2	6.5	4
6 mm x 1.6	FH	X6	10	15	20	25	1.6	6.2	8.2	4

(1) See page 23 for installation tool requirements.

Examples of plastic nuts and wire tie products that can be used with PEM® X-Press™ studs.



Contact Tech Support for more information.



Press-on (kwik) nut can be used to hold down soft materials such as foam, cloth or insulation.



Standard head mounts flush in sheet. Domed head available on special order.

SELF-CLINCHING STUDS AND PINS

FH™/FHS™/FHA™ FLUSH-HEAD PINS

- Flush-head for sheet thickness of .040" / 1 mm and greater.
- FH pins are recommended for use in steel or aluminum sheets HRB (Rockwell "B" Scale) 80 / HB (Hardness Brinell) 150 or less.
- FHS pins are recommended for use in steel or aluminum sheets HRB (Rockwell "B" Scale) 70 / HB (Hardness Brinell) 125 or less.
- FHA pins are recommended for use in aluminum sheets HRB (Rockwell "B" Scale) 50 / HB (Hardness Brinell) 82 or less.

These PEM® pins are only available on special order. See TPS, TP4, and TPXS pins on page 16 for standard diameter pins.

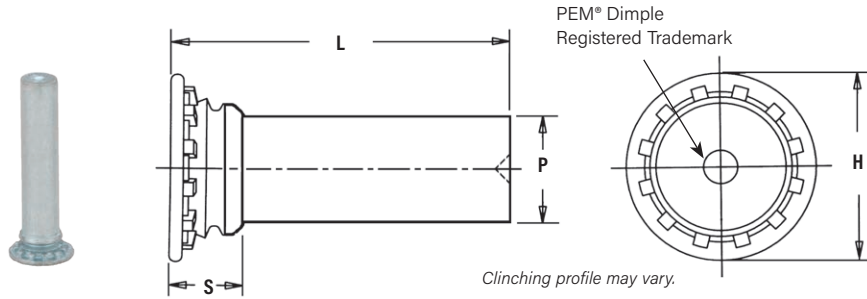

PART NUMBER DESIGNATION

FH	-	094	-	6	ZI
FH	S	- 094	-	6	
FH	A	- 094	-	6	
Type	Material Code	Pin Diameter Code	Length Code	Finish Code	

All dimensions are in inches.

UNIFIED	Nominal Pin Diameter P±.002	Type			Pin Dia. Code	Length Code "L" ±.015 (Length Code in 16ths of an inch)										Min. Sheet Thickness	Hole Size in Sheet +.003 -.000	H ± .015	S Max. (1)	Min. Dist. Hole ⌀ to Edge
		Fastener Material				.250	.312	.375	.500	.625	.750	.875	1.00	1.25	1.50					
		Steel	Stainless Steel	Aluminum																
.073	FH	FHS	FHA	073	4	5	6	8	10	-	-	-	-	-	.040	.085	.15	.075	.19	
.084	FH	FHS	FHA	084	4	5	6	8	10	12	-	-	-	-	.040	.099	.16	.085	.22	
.094	FH	FHS	FHA	094	4	5	6	8	10	12	-	-	-	-	.040	.111	.18	.085	.22	
.103	FH	FHS	FHA	103	4	5	6	8	10	12	-	-	-	-	.040	.118	.18	.085	.22	
.106	FH	FHS	FHA	106	4	5	6	8	10	12	14	16	20	-	.040	.125	.19	.090	.22	
.116	FH	FHS	FHA	116	4	5	6	8	10	12	14	16	20	-	.040	.137	.21	.090	.25	
.120	FH	FHS	FHA	120	4	5	6	8	10	12	14	16	20	24	.040	.137	.21	.090	.25	
.137	FH	FHS	FHA	137	4	5	6	8	10	12	14	16	20	24	.040	.157	.23	.090	.28	
.141	FH	FHS	FHA	141	4	5	6	8	10	12	14	16	20	24	.040	.163	.24	.090	.28	
.160	FH	FHS	FHA	160	4	5	6	8	10	12	14	16	20	24	.040	.189	.26	.100	.28	
.167	FH	FHS	FHA	167	-	5	6	8	10	12	14	16	20	24	.040	.189	.26	.100	.28	
.173	FH	FHS	FHA	173	-	5	6	8	10	12	14	16	20	24	.040	.197	.26	.100	.28	
.207	FH	FHS	FHA	207	-	5	6	8	10	12	14	16	20	24	.062	.236	.32	.135	.31	
.215	FH	FHS	FHA	215	-	-	-	8	10	12	14	16	20	24	.062	.250	.34	.135	.31	
.223	FH	FHS	FHA	223	-	-	-	8	10	12	14	16	20	24	.062	.250	.34	.135	.31	
.273	FH	FHS	FHA	273	-	-	-	8	10	12	14	16	20	24	.093	.312	.38	.160	.38	
.281	FH	FHS	FHA	281	-	-	-	8	10	12	14	16	20	24	.093	.312	.38	.160	.38	

All dimensions are in millimeters.

METRIC	Nominal Pin Diameter P±0.05	Type			Pin Dia. Code	Length Code "L" ±0.4 (Length Code in millimeters)										Min. Sheet Thickness	Hole Size in Sheet +0.08	H ± 0.4	S Max. (1)	Min. Dist. Hole ⌀ to Edge
		Fastener Material				6	8	10	12	15	18	20	25	30	35					
		Steel	Stainless Steel	Aluminum																
3	FH	FHS	FHA	3MM	6	8	10	12	15	18	20	25	30	-	1	3.5	5.3	2.3	6.4	
4	FH	FHS	FHA	4MM	-	8	10	12	15	18	20	25	30	35	1	4.1	6	2.3	7.1	
5	FH	FHS	FHA	5MM	-	8	10	12	15	18	20	25	30	35	1	5.5	7.5	2.55	7.6	

(1) Pin diameter may exceed max. in this region.

SELF-CLINCHING STUDS AND PINS

TPS™/TP4™ FLUSH-HEAD PILOT PINS

- Flush-head for sheet thickness of .040" / 1 mm and greater.
- Satisfies a wide range of positioning, pivot, and alignment applications.
- Chamfered end makes mating hole location easy.
- TPS pins are recommended for use in steel or aluminum sheets HRB (Rockwell "B" Scale) 70 / HB (Hardness Brinell) 125 or less.
- TP4 pins are recommended for use in stainless steel sheets HRB (Rockwell "B" Scale) 92 / HB (Hardness Brinell) 195 or less.

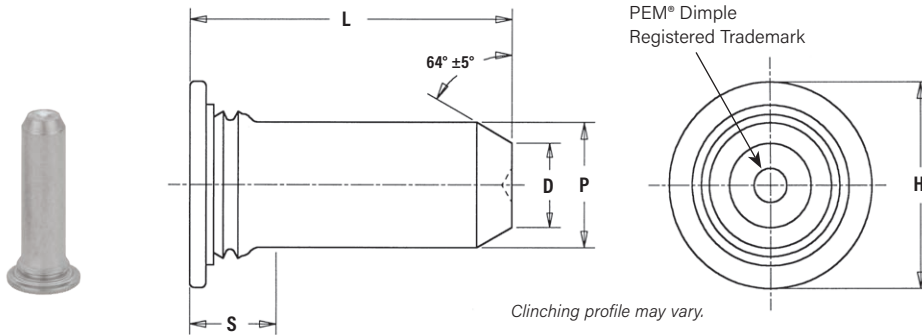

PART NUMBER DESIGNATION

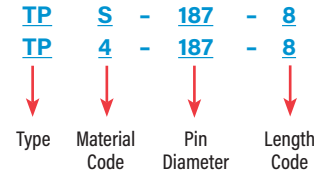

All dimensions are in inches.

UNIFIED	Pin Diameter P ±.002	Type		Pin Diameter Code	Length Code "L" ± .015 (Length Code in 16ths of an inch)					Min. Sheet Thickness	Hole Size in Sheet +.003 -.000	D ±.006	H ±.015	S Max. (1)	Min. Distance Hole \varnothing to Edge
		Fastener Material			.375	.500	.625	.750	1.00						
		300 Series Stainless Steel	400 Series Stainless Steel												
	.125	TPS	TP4	125	6	8	10	12	—	.040	.144	.090	.205	.090	.250
	.187	TPS	TP4	187	6	8	10	12	16	.040	.205	.132	.270	.090	.280
	.250	TPS	TP4	250	—	8	10	12	16	.040	.272	.177	.335	.090	.310

All dimensions are in millimeters.

METRIC	Pin Diameter P ±0.05	Type		Pin Diameter Code	Length Code "L" ± 0.4 (Length Code in millimeters)					Min. Sheet Thickness	Hole Size in Sheet +0.08	D ±0.15	H ±0.4	S Max. (1)	Min. Distance Hole \varnothing to Edge
		Fastener Material			8	10	12	16	—						
		300 Series Stainless Steel	400 Series Stainless Steel												
	3	TPS	TP4	3MM	8	10	12	16	—	1	3.5	2.11	5.2	2.29	6.4
	4	TPS	TP4	4MM	8	10	12	16	—	1	4.5	2.82	6.12	2.29	7.1
	5	TPS	TP4	5MM	—	10	12	16	20	1	5.5	3.53	7.19	2.29	7.6
	6	TPS	TP4	6MM	—	—	12	16	20	1	6.5	4.24	8.13	2.29	7.9

(1) Pin diameter may exceed max. in this region.

If your application requires corrosion resistant fasteners, non-magnetic fasteners, or will be exposed to temperatures above 300° F (149° C), see note at bottom of page 6 about "400 series fasteners for stainless steel panels"

TPXS™ SELF-CLINCHING PILOT PINS

- Meets the ATCA PICMG 3.0 specification.
- 15° tapered point makes engaging the mating hole easy.



Min. Sheet Thickness: 1 mm
 Hole Size In Sheet: 3.5 mm +0.08
 Min. Dist. Hole C/L To Edge: 6.4 mm

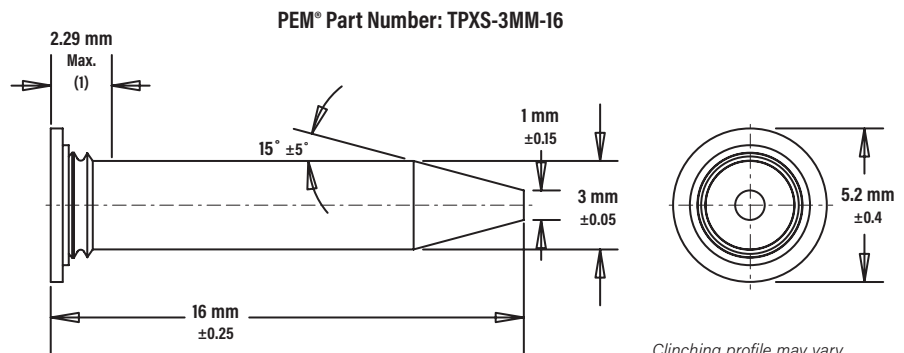

(1) Pin diameter may exceed max. in this region.



SELF-CLINCHING STUDS AND PINS

MATERIAL AND FINISH SPECIFICATIONS

Type	Threads (1)	Fastener Materials							Standard Finishes			Optional Finishes (2)		
	External, ASME B1.1, 2A / ASME B1.13M, 6g	Hardened Carbon Steel	Hardened Medium Carbon Alloy Steel	Aluminum (plain finish)	CDA 510 Phosphor Bronze	Age Hardened A286 Stainless Steel	300 Series Stainless Steel	400 Series Stainless Steel	No Finish (4)	Zinc plated 5µm, Colorless (5)	Passivated and/or Tested Per ASTM A380	Zinc plated 5µm, Yellow (5)	No Finish (4)	Rust Preventative Oil
FH	▪	▪									▪			
FHS	▪						▪				▪			
FHA	▪			▪					▪ (3)					
FH4	▪							▪						
FHP	▪					▪					▪			
FHL	▪	▪									▪			
FHLS	▪						▪				▪			
TFH	▪	▪									▪			
TFHS	▪						▪				▪			
HFE	▪	▪									▪			
THFE	▪	▪									▪			
HFH	▪	▪									▪			
HFHB	▪				▪					▪				
HFHS	▪						▪				▪			
HFG8	▪		▪								▪			
HF109	▪		▪								▪			
HFLH	▪		▪									▪ (6)		
SGPC	▪						▪				▪			
FHX		▪									▪			▪
TPS							▪				▪			
TP4								▪			▪			
TPXS							▪				▪			
Part Number Codes for Finishes									X	ZI	None	ZC	X	X

Type	For use in Sheet Hardness (7)								
	HRB 50 / HB 82 or Less	HRB 55 / HB 83 or Less	HRB 70 / HB 125 or Less	HRB 80 / HB 150 or Less	HRB 85 / HB 165 or Less	HRB 89 / HB 180 or Less	HRB 92 / HB 195 or Less	HRB 96 / HB 216 or Less	Any Sheet Hardness
FH				▪					
FHS			▪						
FHA	▪								
FH4							▪		
FHP							▪		
FHL				▪					
FHLS			▪						
TFH				▪					
TFHS			▪						
HFE					▪				
THFE					▪				
HFH					▪				
HFHB		▪							
HFHS			▪						
HFG8						▪			
HF109						▪			
HFLH								▪	
SGPC									▪
FHX				▪					
TPS			▪						
TP4							▪		
TPXS			▪						

- (1) For plated studs, Class 2A/6g, the maximum major and pitch diameter, after plating, may equal basic sizes and be gauged to Class 3A/4h. Per ASME B1.1, Section 7, Paragraph 7.2 and ASME B1.13M, Section 8, paragraph 8.2.
- (2) Special order with additional charge.
- (3) Part numbers for aluminum studs have no finish suffix.
- (4) "X" suffix studs may have pitch diameters and major diameters below 2A/6g minimum size, per ANSI B1.1, Section 7, and B1.13M, Section 8 to allow for minimum of 0.0002" / 0.0051 mm of plating.
- (5) See PEM Technical Support section of our web site for related plating standards and specifications.
- (6) With rust preventative oil.
- (7) HRB - Hardness Rockwell "B" Scale. HB - Hardness Brinell.



SELF-CLINCHING STUDS AND PINS

INSTALLATION - FH™/FHS™/FHA™ THREADED STUDS

1. Prepare properly sized mounting hole in sheet. Do not perform any secondary operations such as deburring.
2. Insert stud through mounting hole (punch side) of sheet and into anvil hole.
3. With punch and anvil surfaces parallel, apply squeezing force to embed the head of the stud flush in the sheet. In most cases, when using sheets .060" / 1.51 mm and thicker, the anvil requires only a straight thru hole to accommodate the stud (see illustrations below for details). For sheets less than .060 / 1.51 mm, the hole requires a countersink with dimension A at the top to provide for metal flow around the shank of the stud.

Tooling for sheet thicknesses less than .060 / 1.51 mm with #2 thru #10 / M3 thru M5 thread sizes and less than .093" / 2.36 mm for 1/4" / M6 threads.

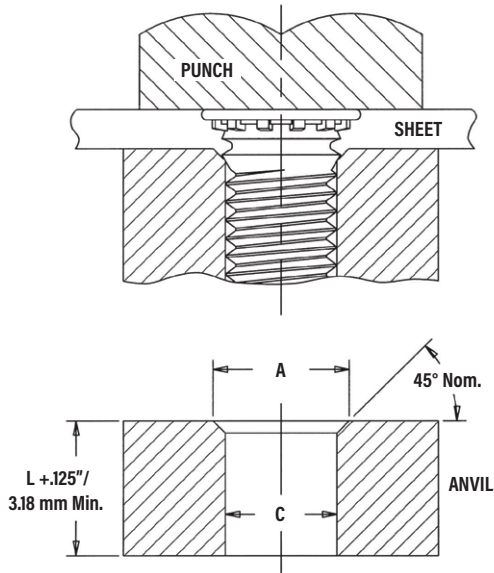

Tooling for sheet thicknesses .060" / 1.51 mm and greater with #2 thru #10 / M3 thru M5 thread sizes and .093" / 2.36 mm and greater for 1/4" and 5/16" / M6 and M8 threads.

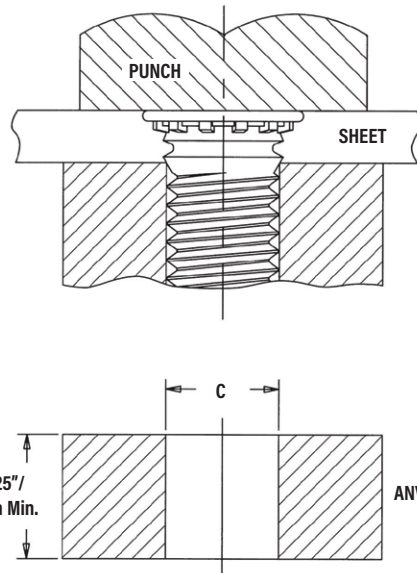

See page 5 for "L".

PEMSERTER® Installation Tooling

	Thread Code	Anvil Dimensions (in.)		Anvil Part No. For Sheets > .060"	Anvil Part No. For Sheets ≤ .059"	Punch Part Number
		A	C			
UNIFIED	256	.110-.114	.087-.090	970200005300	970200240300	975200048
	440	.136-.140	.113-.116	970200006300	970200241300	
	632	.162-.166	.139-.142	970200007300	970200243300	
	832	.188-.192	.165-.168	970200008300	970200245300	
	024/032	.216-.220	.191-.194	970200009300	970200246300	
				For Sheets > .093"	For Sheets ≤ .092"	
	0420	.295-.300	.250-.253	970200010300	970200249300	975200048
0518	.334-.338	.3125-.3155	970200011300	—		

	Thread Code	Anvil Dimensions (mm)		Anvil Part No. For Sheets > 1.51 mm	Anvil Part No. For Sheets ≤ 1.5 mm	Punch Part Number
		A + 0.1	C + 0.08			
METRIC	M2.5	3.1	2.53	970200300300	970200493300	975200048
	M3	3.6	3.03	970200229300	970200242300	
	M3.5	4.1	3.53	970200007300	970200243300	
	M4	4.6	4.03	970200019300	970200244300	
	M5	5.6	5.03	970200020300	970200247300	
				For Sheets > 2.36 mm	For Sheets ≤ 2.36 mm	
	M6	6.6	6.03	970200230300	970200248300	975200048
	M8	8.6	8.03	970200213300	—	

SELF-CLINCHING STUDS AND PINS

INSTALLATION - FH4™/FHP™ STUDS FOR STAINLESS STEEL SHEETS

1. Prepare properly sized mounting hole in sheet. Do not perform any secondary operations such as deburring.
2. Insert stud through mounting hole (punch side) of sheet and into anvil hole.
3. With punch and anvil surfaces parallel, apply squeezing force to embed the head of the stud flush in the sheet.

For FH4/FHP studs, a special anvil with a raised ring is required to create a proper installation. The raised ring acts as a second displacer of the stainless sheet material, thereby ensuring that the annular groove is filled. Please see page 6 for recommended sheet thickness range. The special anvils are available from PEM stock or can be machined from suitable tool steel. A hardness of HRC 55 / HB 547 minimum is required to provide long anvil life. We recommend measuring the "P" dimension every 5000 installations to ensure that the anvil remains within specification.

PEMSERTER® Installation Tooling

UNIFIED	Thread Code	Anvil Dimensions (in.)						Anvil Part Number	Punch Part Number
		A	B	C	P	R ₁ Max.	R ₂ Max.		
		+ .003 - .000							
	440	.113	.144	.174	.010	.003	.005	8001645	975200048
	632	.140	.170	.200	.010	.003	.005	8001644	
	832	.166	.202	.236	.010	.003	.005	8001643	
	032	.191	.235	.275	.010	.003	.005	8001642	
	0420	.252	.324	.360	.020	.003	.005	8002535	

METRIC	Thread Code	Anvil Dimensions (mm)						Anvil Part Number	Punch Part Number
		A	B	C	P	R ₁ Max.	R ₂ Max.		
			+0.08	±0.05	±0.05	±0.25			
	M3	3.05	3.81	4.57	0.25	0.08	0.13	8001678	975200048
	M4	4.04	4.95	5.82	0.25	0.08	0.13	8001677	
	M5	5.08	6.15	7.16	0.25	0.08	0.13	8001676	
	M6	6.05	7.87	8.79	0.51	0.08	0.13	8002536	

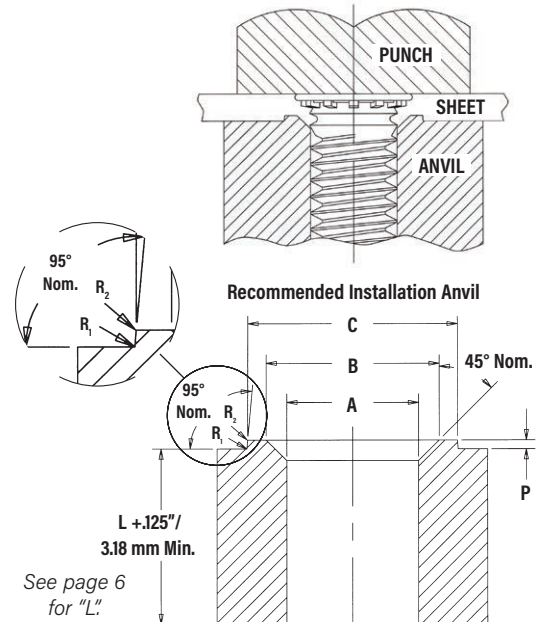

See page 6 for "L"

INSTALLATION - FHL™/FHLS™ STUDS

1. Prepare properly sized mounting hole in sheet. Do not perform any secondary operations such as deburring.
2. Insert stud through mounting hole (punch side) of sheet and into anvil hole.
3. With punch and anvil surfaces parallel, apply squeezing force to embed the head of the stud flush in the sheet. For sheets .060" / 1.51 mm and thicker, the anvil requires only a straight thru hole to accommodate the stud. For sheets less than .060" / 1.51 mm, the hole requires a countersink with dimension A at the top to provide for metal flow around the shank of the stud.

Tooling for sheet thicknesses less than .060" / 1.51 mm.

Tooling for sheet thicknesses .060" / 1.51 mm and greater.

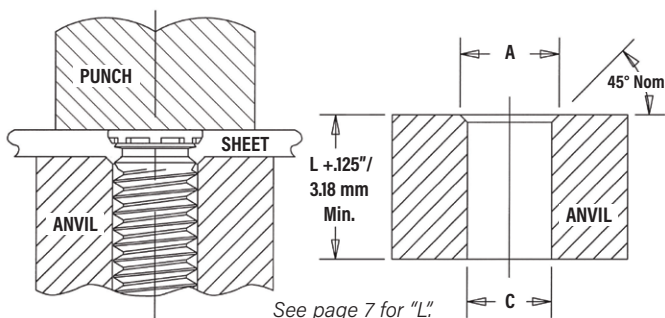

See page 7 for "L"

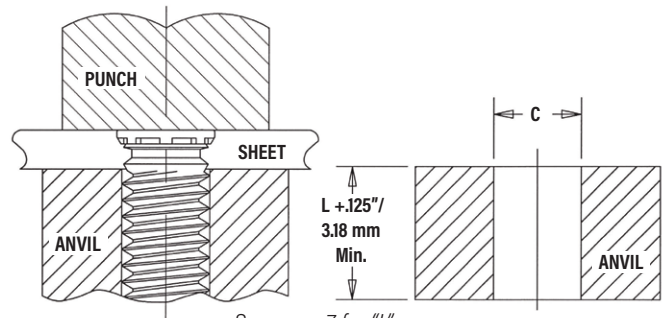

See page 7 for "L"

PEMSERTER® Installation Tooling

UNIFIED	Thread Code	Anvil Dimensions (in.)		Anvil Part No. For Sheets > .060"	Anvil Part No. For Sheets ≤ .059"	Punch Part Number
		A	C			
	256	.110-.114	.087-.090	8003313	8003297	975200997
	440	.136-.140	.113-.116	8003618	8003298	
	632	.162-.166	.139-.142	8003314	8003299	
	832	.188-.192	.165-.168	8003315	8003300	
	032	.216-.220	.191-.194	8003619	8003301	

METRIC	Thread Code	Anvil Dimensions (mm)		Anvil Part No. For Sheets > 1.51 mm	Anvil Part No. For Sheets ≤ 1.5 mm	Punch Part Number
		A	C			
			±0.05	+0.08		
	M2.5	3.1	2.53	8003316	8003302	975200997
	M3	3.6	3.03	8003317	8003303	
	M3.5	4.1	3.53	8003318	8003304	
	M4	4.6	4.03	8003620	8003305	
	M5	5.6	5.03	8003319	8003306	



SELF-CLINCHING STUDS AND PINS

INSTALLATION - TFH™/TFHS™ NON-FLUSH STUDS

1. Prepare properly sized mounting hole in sheet. Do not perform any secondary operations such as deburring.
2. Insert stud through mounting hole (punch side) of sheet and into anvil hole.
3. With punch and anvil surfaces parallel, apply squeezing force until the punch contacts the sheet. When installed, the stud head is not flush but will protrude approximately .025" / 0.64 mm. For sheets .030" / 0.76 mm and thicker, the anvil requires only a straight thru hole to accommodate the stud. For sheets less than .030" / 0.76 mm down to .020" / 0.51 mm, the hole requires a countersink with dimension A at the top to provide for metal flow around the shank of the stud. The standard punch design below provides clearance for the stud head and reduces chances of over squeezing the head of the stud into the sheet metal.

Tooling for sheet thicknesses less than .030" / 0.76 mm down to .020" / 0.51 mm.

Tooling for sheet thicknesses .030" / 0.76 mm and greater.

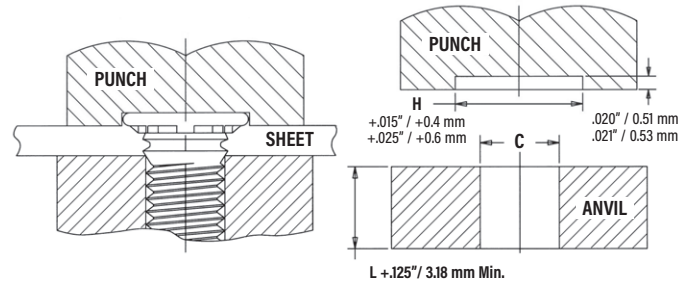
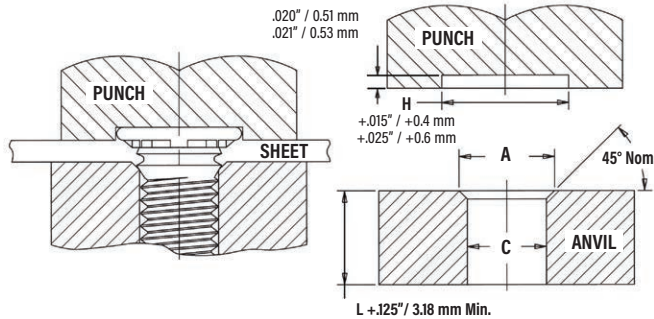

See page 8 for "L"

PEMSERTER® Installation Tooling

UNIFIED	Thread Code	Anvil Dimensions (in.)		Anvil Part No. For Sheets > .030"	Anvil Part No. For Sheets .020" - .029"	Punch Part Number
		A	C			
	256	.110-.114	.087-.090	970200005300	970200240300	970200235400
	440	.136-.140	.113-.116	970200006300	970200241300	970200236400
	632	.162-.166	.139-.142	970200007300	970200243300	970200237400
	832	.188-.192	.165-.168	970200008300	970200245300	970200238400
	032	.216-.220	.191-.194	970200009300	970200246300	970200239400
	0420	.295-.300	.250-.253	970200010300	970200249300	970200496400

METRIC	Thread Code	Anvil Dimensions (mm)		Anvil Part No. For Sheets > 0.76 mm	Anvil Part No. For Sheets 0.51 - 0.75 mm	Punch Part Number
		A + 0.1	C + 0.08			
	M3	3.6	3.03	970200229300	970200242300	970200236400
	M3.5	4.1	3.53	970200007300	970200243300	970200237400
	M4	4.6	4.03	970200019300	970200244300	970200238400
	M5	5.6	5.03	970200020300	970200247300	970200239400
	M6	6.6	6.03	970200230300	970200248300	970200496400

INSTALLATION - HFH™/HFHB™/HFHS™ STUDS

1. Prepare properly sized mounting hole in sheet. Do not perform any secondary operations such as deburring.
2. Insert stud through mounting hole (punch side) of sheet and into anvil hole.
3. With punch and anvil surfaces parallel, apply squeezing force on the punch sufficient only to embed the ribs on the head of the stud into the sheet. The standard punch design provides clearance for the stud head and reduces chances of over squeezing.

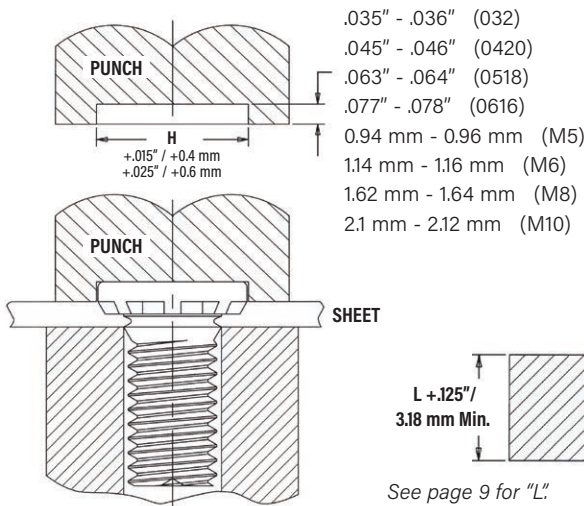

See page 9 for "L"

PEMSERTER® Installation Tooling

UNIFIED	Thread Code	Anvil Dimensions (in.)	Anvil Part Number	Punch Part Number
		C		
	032	.191 - .194	970200009300	970200311400
	0420	.250 - .253	970200010300	970200312400
	0518	.3125 - .3155	970200011300	970200313400
	0616	.375 - .378	970200004300	970200314400

METRIC	Thread Code	Anvil Dimensions (mm)	Anvil Part Number	Punch Part Number
		C + 0.08		
	M5	5.03	970200020300	970200311400
	M6	6.03	970200230300	970200312400
	M8	8.03	970200231300	970200313400
	M10	10.03	970200402300	970200491400

SELF-CLINCHING STUDS AND PINS

INSTALLATION - HFE™/THFE™/HFLH™ STUDS

HFE™/HFLH™ STUDS

1. Prepare properly sized mounting hole in sheet. Do not perform any secondary operations such as deburring.
2. Insert stud through mounting hole (punch side) of sheet and into anvil hole.
3. With punch and anvil surfaces parallel, apply squeezing force on the punch sufficient only to embed the ribs on the head of the stud into the sheet.

Tooling for sheet thicknesses less than .060" / 1.51 mm with #10 / M5 and 1/4" / M6 thread sizes and less than .075" / 1.9 mm with 5/16" / M8 threads.

Tooling for sheet thicknesses .060" / 1.51 mm and greater with #10 / M5 and 1/4" / M6 thread sizes and .075" / 1.9 mm and greater with 5/16" / M8 threads.

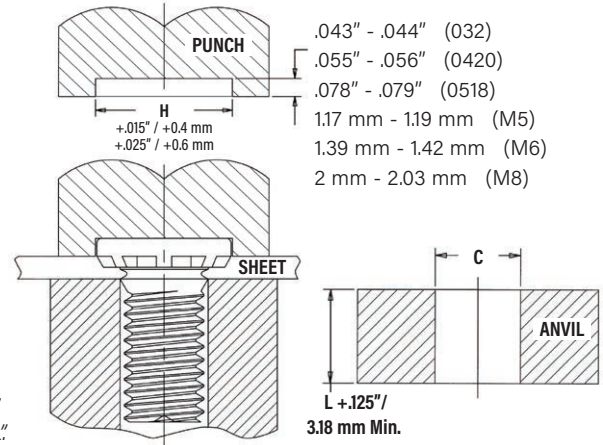
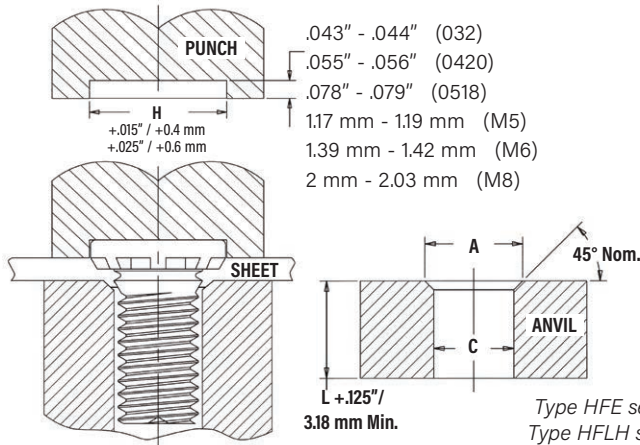

PEMSERTER® Installation Tooling

UNIFIED	Thread Code	Anvil Dimensions (in.)		Anvil Part No. For Sheets > .060"	Anvil Part No. For Sheets .040" - .060"	Punch Part Number
		A	C			
	032	.216-.220	.191-194	970200009300	970200246300	8003707
	0420	.295-.300	.250-253	970200010300	8003702	8003708
	0518	.334-.338	.3125-.3155	970200011300	8003703	8003709

METRIC	Thread Code	Anvil Dimensions (mm)		Anvil Part No. For Sheets > 1.51 mm	Anvil Part No. For Sheets 1 mm - 1.51 mm	Punch Part Number
		A + 0.1	C + 0.08			
	M5	5.6	5.03	970200020300	8003704	8003710
	M6	6.6	6.03	970200230300	8003705	8003711
	M8	8.6	8.03	970200231300	8003706	8003712

THFE™ STUDS

Tooling for sheet thicknesses less than .052" / 1.31 mm with 1/4" / M6 thread sizes, and less than .067" / 1.71 mm with 5/16" / M8 thread sizes.

Tooling for sheet thicknesses .052" / 1.31 mm and greater with 1/4" / M6 and .067" / 1.71 mm thread sizes and greater with 5/16" / M8 threads.

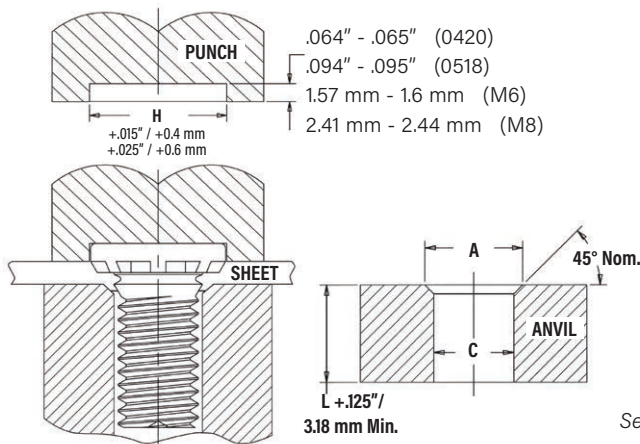

See page 10 for "L."

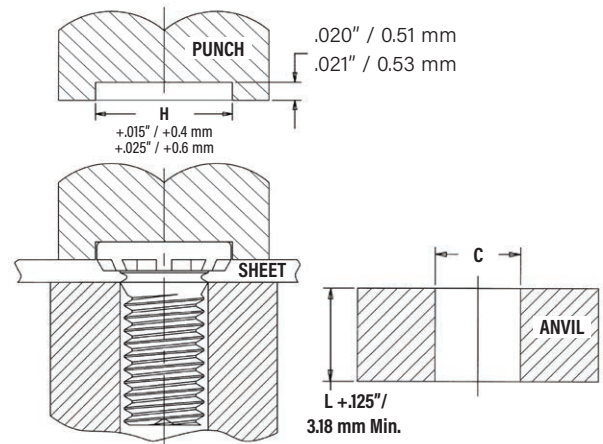

PEMSERTER® Installation Tooling

UNIFIED	Thread Code	Anvil Dimensions (in.)		Anvil Part No. For Sheets > .051"	Anvil Part No. For Sheets .031" - .051"	Punch Part Number
		A	C			
	0420	.302-.306	.250-253	970200010300	8019886	8019890
	0518	.374-.378	.3125-.3155	970200011300	8019887	8019891

METRIC	Thread Code	Anvil Dimensions (mm)		Anvil Part No. For Sheets > 1.3 mm	Anvil Part No. For Sheets 0.8 - 1.3 mm	Punch Part Number
		A + 0.1	C + 0.08			
	M6	7.25	6.03	970200230300	8019888	8019892
	M8	9.55	8.03	970200231300	8019889	8019893



SELF-CLINCHING STUDS AND PINS

INSTALLATION - HFG8™/HF109™ STUDS

1. Prepare properly sized mounting hole in sheet. Do not perform any secondary operations such as deburring.
2. Insert stud through mounting hole (punch side) of sheet and into anvil hole.
3. With punch and anvil surfaces parallel, apply squeezing force on the punch sufficient only to embed the ribs on the head of the stud into the sheet. Note that for sheets .060" / 1.51 mm and thicker, the anvil requires only a straight thru hole to accommodate the stud. For sheets less than .060" / 1.51 mm to less than .075" / 1.9 mm, the hole requires a countersink with dimension A at the top to provide for metal flow around the shank of the stud.

Tooling for sheet thicknesses less than .060" / 1.51 mm with #10 / M5 and 1/4" / M6 thread sizes and less than .075" / 1.9 mm with 5/16" / M8 threads.

Tooling for sheet thicknesses .060" / 1.51 mm and greater with #10 / M5 and 1/4" / M6 thread sizes and .075" / 1.9 mm and greater with 5/16" / M8 threads.

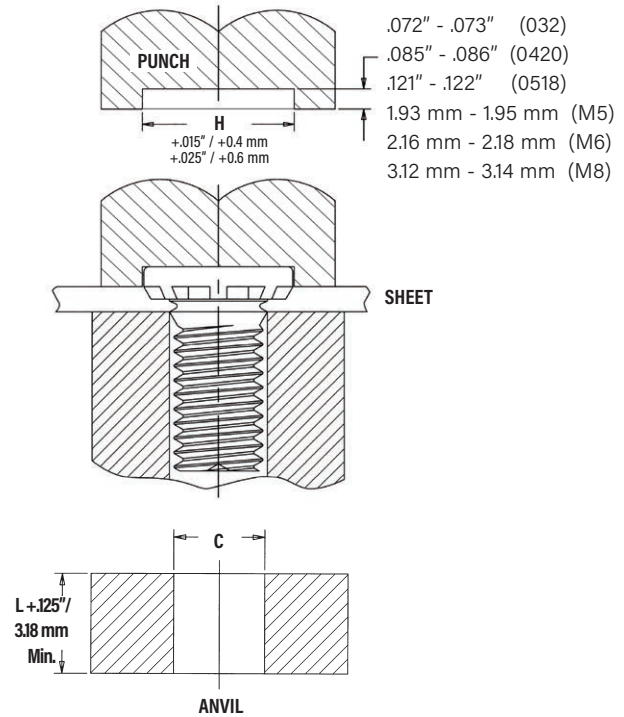
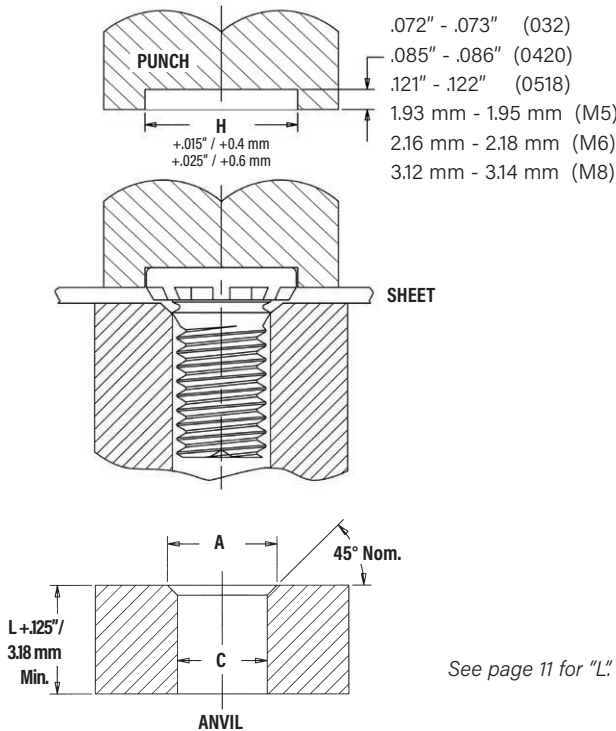

See page 11 for "L"

PEMSERTER® Installation Tooling

UNIFIED	Thread Code	Anvil Dimensions (in.)		Anvil Part Number (Standard Sheet)	Anvil Part Number (Thin Sheet)	Punch Part Number
		A	C			
	032	.216 - .220	.191 - .194	970200009300	970200246300	8014456
	0420	.273 - .278	.250 - .253	8021609	8021613	8014458
	0518	.334 - .338	.3125 - .3155	8021610	8021614	8014460

METRIC	Thread Code	Anvil Dimensions (mm)		Anvil Part Number (Standard Sheet)	Anvil Part Number (Thin Sheet)	Punch Part Number
		A +0.1	C +0.08			
	M5	5.6	5.03	970200020300	8003704	8014457
	M6	6.6	6.03	8021611	8021615	8014459
	M8	8.6	8.03	8021612	8021616	8014461

INSTALLATION - SGPC™ SWAGING COLLAR STUDS

1. Prepare properly sized mounting hole in sheet.
2. Insert fastener through mounting hole (punch side) as shown in drawing.
3. With installation punch and anvil surfaces parallel, apply squeezing force until the punch pushes over the protruding knurls of the stud.

PEMSERTER® Installation Tooling

UNIFIED	Thread Code	Punch Dimensions (in.)		Punch Part Number	Anvil Dimensions (in.)		Anvil Part Number
		A	B		C	P	
		+0.004 -0.000	+0.000 -0.001		+0.001	+0.000 -0.002	
	256	.209	.019	8015111	.087	.014	8016983
	440	.248	.022	8015112	.113	.014	8016984
	632	.276	.022	8015113	.139	.014	8016985
	832	.299	.022	8015114	.165	.014	8016986
	032	.327	.022	8015115	.191	.014	8016987
	0420	.386	.026	8015116	.251	.014	8016988

METRIC	Thread Code	Punch Dimensions (mm)		Punch Part Number	Anvil Dimensions (mm)		Anvil Part Number
		A	B		C	P	
		+0.1	-0.025		+0.025	-0.05	
	M2.5	5.5	0.47	8015117	2.53	0.35	8016989
	M3	6.5	0.57	8015118	3.03	0.35	8016990
	M4	7.5	0.57	8015119	4.03	0.35	8016991
	M5	8.5	0.57	8015120	5.03	0.35	8016992
	M6	9.5	0.67	8015121	6.03	0.35	8016993

NOTE: For panel design information, go to http://www.pemnet.com/SGPC_Panel_Designs.pdf

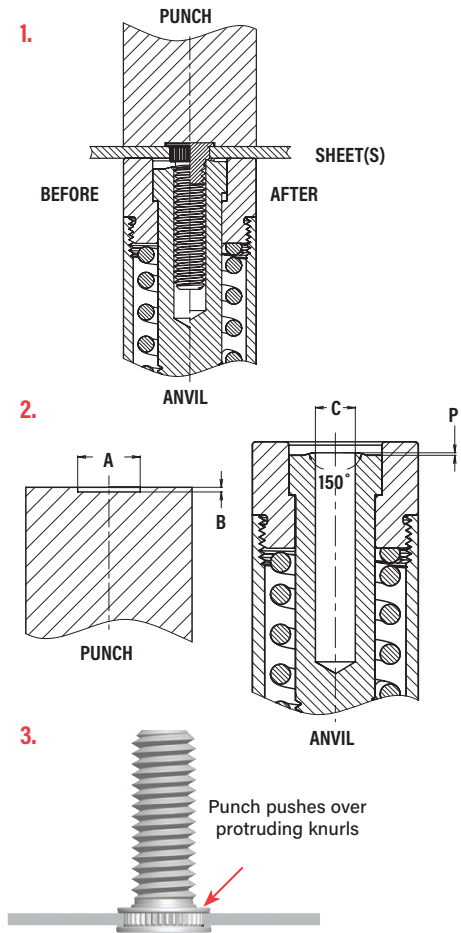

INSTALLATION - FHX™ STUDS

1. Prepare properly sized mounting hole in sheet. Do not perform any secondary operations such as deburring.
2. Insert stud through mounting hole (punch side) of sheet and into anvil hole.
3. With punch and anvil surfaces parallel, apply squeezing force to embed the head of the stud flush in the sheet. In most cases, when using sheets 1.51 mm and thicker, the anvil requires only a straight thru hole to accommodate the stud (see illustrations below for details). For sheets less than 1.51 mm, the hole requires a countersink with dimension A at the top to provide for metal flow around the shank of the stud.

Tooling for sheet thicknesses less than 1.51 mm with 5 mm thread size and less than 2.4 mm for 6 mm thread size.

Tooling for sheet thicknesses 1.51 mm and greater with 5 mm thread size and 2.4 mm and greater for 6 mm thread size.

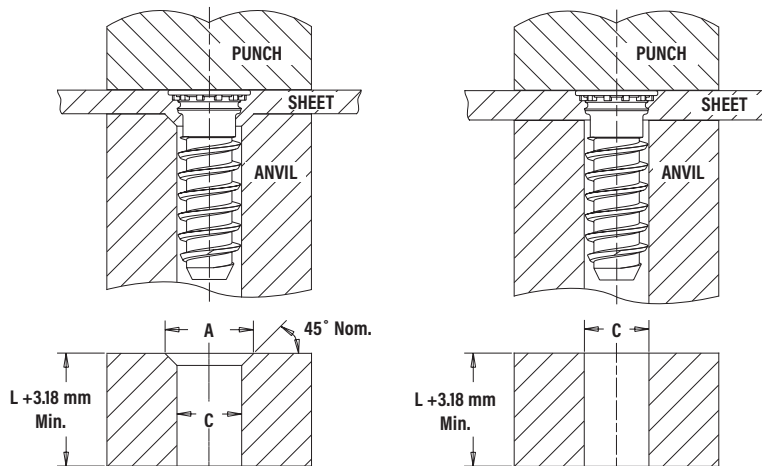

See page 14 for "L."

PEMSERTER® Installation Tooling

Thread Code	Anvil Dimensions (mm)		Anvil Part No. For Sheets < 1.51	Anvil Part No. For Sheets ≥ 1.51	Punch Part Number
	A	C			
X5	6.12 - 6.22	5.23 - 5.31	8021189	8021188	975200048
				< 2.4	≥ 2.4
X6	7.04 - 7.14	6.25 - 6.33	8021191	8021190	975200048



SELF-CLINCHING STUDS AND PINS

INSTALLATION - FH™/FHS™/FHA™ PINS

1. Prepare properly sized mounting hole in sheet. Do not perform any secondary operations such as deburring.
2. Insert pin through mounting hole (punch side) of sheet and into anvil hole.
3. With punch and anvil surfaces parallel, apply squeezing force to embed the head of the pin flush in the sheet. In most cases, when using sheets .060" / 1.51 mm and thicker, the anvil requires only a straight thru hole to accommodate the pin (see illustrations below for details). For sheets less than .060" / 1.51 mm, the hole requires a countersink with dimension A at the top to provide for metal flow around the shank of the pin.

Tooling for sheet thicknesses less than .060" / 1.52 mm with 073 thru 173 / 3 mm thru 5 mm pin diameter codes and for sheet thicknesses less than .093" / 2.36 mm with 207 thru 223 pin diameter codes.

Tooling for sheet thicknesses greater than .060" / 1.52 mm with 073 thru 173 / 3 mm thru 5 mm pin diameter codes and for sheet thicknesses greater than .093" / 2.36 mm with 207 thru 281 pin diameter codes.

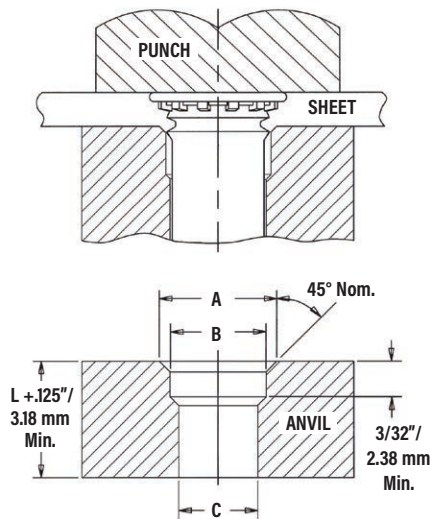

See page 15 for "L".

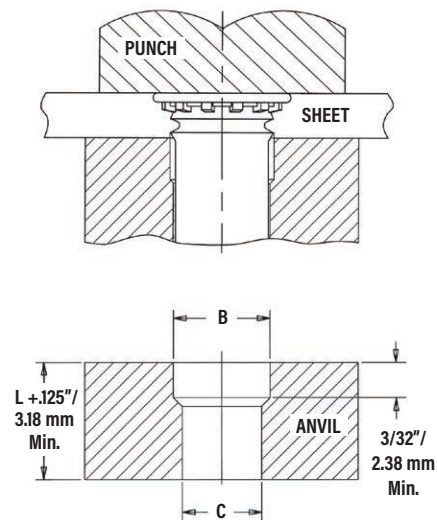

PEMSERTER® Installation Tooling

UNIFIED	Pin Dia. Code	Anvil Dimensions (in.)		
		A +.004 -.000	B ±.002	C ±.002
073	.116	.089	.078	
084	.133	.103	.089	
094	.162	.115	.099	
103	.166	.122	.109	
106	.168	.129	.111	
116	.191	.141	.121	
120	.191	.141	.125	
137	.215	.161	.144	
141	.216	.167	.147	
160	.244	.193	.166	
167	.244	.193	.172	
173	.250	.201	.180	
207	.286	.240	.213	
215	.290	.254	.221	
223	.298	.254	.228	
273	.325	.316	.277	
281	.320	.316	.290	

METRIC	Pin Dia. Code	Anvil Dimensions (mm)		
		A +0.1	B ±0.05	C ±0.05
3MM	4.9	3.61	3.1	
4MM	5.44	4.19	4.1	
5MM	6.93	5.61	5.1	

INSTALLATION - TPS™/TP4™/TPXS™ PILOT PINS

1. Prepare properly sized mounting hole in sheet. Do not perform any secondary operations such as deburring.
2. Insert pin through mounting hole (punch side) of sheet and into anvil hole.
3. With punch and anvil surfaces parallel, apply squeezing force to embed the head of the pin flush in the sheet.

PEMSERTER® Installation Tooling

UNIFIED	Pin Dia. Code	Test Sheet Thickness (in.)	Anvil Dimensions (in.)		Anvil Part Number	Punch Part Number
			A ±.002	C ±.002		
125		.040 - .060	.160	.130	8003284	975200048
		Over .060	(1)		8003278	
187		.040 - .065	.220	.192	8003285	
		Over .065	(1)		8003279	
250		.040 - .075	.285	.255	8003286	
		Over .075	(1)		8003280	

METRIC	Pin Dia. Code	Test Sheet Thickness (mm)	Anvil Dimensions (mm)		Anvil Part Number	Punch Part Number
			A ±0.05	C ±0.05		
3MM		1 - 1.7	3.88	3.11	8008096	975200048
		Over 1.7	(1)		8008095	
4MM		1 - 1.7	4.88	4.11	8003287	
		Over 1.7	(1)		8003281	
5MM		1 - 1.8	5.89	5.13	8003288	
		Over 1.8	(1)		8003282	
6MM		1 - 1.9	6.89	6.12	8003289	
		Over 1.9	(1)		8003283	

(1) Chamfered anvil not required.

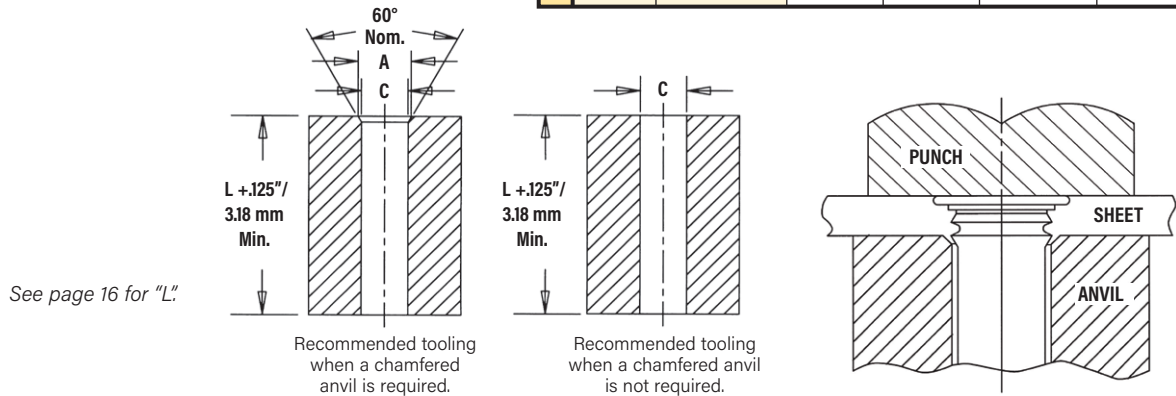

INSTALLATION NOTES

- For best results we recommend using a PEMSERTER® press for installation of PEM self-clinching fasteners. Please check our website for more information.
- Visit the Animation Library on our website to view the installation process [for select products](#).

SELF-CLINCHING STUDS AND PINS

Published installation forces are for general reference. Actual set-up and confirmation of complete installation should be made by observing proper seating of fastener as described in the installation steps. Other performance values reported are averages when all proper installation parameters and procedures are followed. Variations in mounting hole size, sheet material, and installation procedure may affect performance. Performance testing this product in your application is recommended. We will be happy to provide technical assistance and/or samples for this purpose.

PERFORMANCE DATA - FH™/FHS™ FLUSH-HEAD STUDS

UNIFIED	Thread Code	Rec. Nut Tightening Torque (in. lbs.) (1)	Type	Test Sheet Thickness & Material	Sheet Hardness HRB	Installation (lbs.)	Pushout (lbs.)	Torque-out (in. lbs.)	Pull Thru (lbs.)
	256	4.4	FH	.062" Aluminum	29	2000	100	5	425
		2.7	FHS	.062" Aluminum	29	2000	100	4.5	300
		4.4	FH	.060" Steel	59	2500	180	5	425
		2.7	FHS	.060" Steel	59	2500	180	4.5	300
	440	8.7	FH	.064" Aluminum	29	3800	170	10	650
		5.9	FHS	.064" Aluminum	29	3200	170	8	500
		8.7	FH	.060" Steel	59	4300	275	10	650
		5.9	FHS	.060" Steel	59	4700	275	8	500
	632	14	FH	.064" Aluminum	29	3800	180	17	850
11		FHS	.064" Aluminum	29	3500	180	16	775	
14		FH	.060" Steel	59	4700	300	20	850	
11		FHS	.060" Steel	59	5000	300	16	775	
832	20	FH	.064" Aluminum	29	4800	220	28	1000	
	16	FHS	.064" Aluminum	29	4500	220	28	940	
	25	FH	.060" Steel	59	6800	375	40	1270	
	19	FHS	.060" Steel	59	5500	375	28	1130	
032/024	28	FH	.064" Aluminum	29	5500	270	30	1220	
	24	FHS	.064" Aluminum	29	5500	270	30	1220	
	32	FH	.060" Steel	59	7500	450	60	1410	
	28	FHS	.060" Steel	59	6800	450	50	1410	
0420	69	FH	.093" Aluminum	28	6500	310	65	2300	
	55	FHS	.093" Aluminum	28	6500	310	65	2100	
	77	FH	.088" Steel	46	9500	575	100	2550	
	67	FHS	.088" Steel	46	10000	575	100	2550	
0518	85	FH	.093" Aluminum	28	6500	430	100	2260	
	74	FHS	.093" Aluminum	28	6700	430	100	2260	
	130	FH	.093" Steel	46	10000	650	175	3475	
	102	FHS	.093" Steel	46	11200	650	175	3120	

METRIC	Thread Code	Rec. Nut Tightening Torque (N-m) (1)	Type	Test Sheet Thickness & Material	Sheet Hardness HRB	Installation (kN)	Pushout (N)	Torque-out (N-m)	Pull Thru (N)
	M2.5	0.78	FH	1.6 mm Aluminum	29	8.9	465	1.0	2600
		0.48	FHS	1.6 mm Aluminum	29	11.6	465	0.8	1820
		0.84	FH	1.5 mm Steel	59	11.1	740	1.0	2800
		0.48	FHS	1.5 mm Steel	59	13.8	740	0.8	1820
	M3	1.1	FH	1.6 mm Aluminum	29	12.9	600	1.7	3150
		0.81	FHS	1.6 mm Aluminum	29	12.9	600	1.3	2570
		1.4	FH	1.5 mm Steel	59	14.7	820	1.7	3840
		0.77	FHS	1.5 mm Steel	59	14.7	820	1.3	2440
	M3.5	1.6	FH	1.6 mm Aluminum	29	15.6	800	1.7	3780
1.3		FHS	1.6 mm Aluminum	29	15.6	800	1.7	3445	
1.6		FH	1.5 mm Steel	59	22.3	1335	2.8	3780	
1.3		FHS	1.5 mm Steel	59	22.3	1335	2.0	3445	
M4	2.1	FH	1.6 mm Aluminum	29	20	975	2.9	4448	
	1.8	FHS	1.6 mm Aluminum	29	22.3	975	2.9	4180	
	2.7	FH	1.5 mm Steel	59	28.9	1780	4.2	5650	
	2	FHS	1.5 mm Steel	59	26.7	1780	2.9	4775	
M5	3.1	FH	1.6 mm Aluminum	29	24.5	1070	3.5	5170	
	2.5	FHS	1.6 mm Aluminum	29	24.5	1070	3.5	4760	
	3.8	FH	1.5 mm Steel	59	33.4	2000	6.5	6270	
	3.2	FHS	1.5 mm Steel	59	32.5	2000	6.3	6000	
M6	7.3	FH	2.4 mm Aluminum	28	28.9	1660	7.3	10200	
	5.7	FHS	2.4 mm Aluminum	28	28.9	1660	7.3	9090	
	8.1	FH	2.2 mm Steel	46	44.5	2560	11.3	11300	
	6.7	FHS	2.2 mm Steel	46	44.5	2560	10.1	10600	
M8	10	FH	2.4 mm Aluminum	28	29.8	1910	11.3	10500	
	8	FHS	2.4 mm Aluminum	28	29.8	1910	11.3	9540	
	15	FH	2.4 mm Steel	46	44.5	2890	19.2	15450	
	11	FHS	2.4 mm Steel	46	49.8	2890	17.5	13630	

(1) Tightening torque shown is a theoretical value calculated to induce a load of 75% of minimum axial yield strength of the stud with an assumed K value or nut factor equal to 0.20. In some applications tightening torque may need to be adjusted based on the actual K value.



SELF-CLINCHING STUDS AND PINS

PERFORMANCE DATA - FHA™ FLUSH-HEAD STUDS

UNIFIED	Thread Code	Rec. Nut Tightening Torque (in. lbs.) ⁽¹⁾	Type	Test Sheet Thickness & Material	Sheet Hardness HRI5T	Installation (lbs.)	Pushout (lbs.)	Torque-out (in. lbs.)	Pull Thru (lbs.)
	440	3.6	FHA	.061" 5052-H34 Aluminum	75	2500	155	4	270
	632	6.3	FHA	.061" 5052-H34 Aluminum	75	2600	180	8	380
	832	9.8	FHA	.061" 5052-H34 Aluminum	73	3200	190	15	500
	032	14	FHA	.061" 5052-H34 Aluminum	75	3200	220	28	600
	0420	32	FHA	.062" 5052-H34 Aluminum	75	5500	300	55	1050

METRIC	Thread Code	Rec. Nut Tightening Torque (N-m) ⁽¹⁾	Type	Test Sheet Thickness & Material	Sheet Hardness HRI5T	Installation (kN)	Pushout (N)	Torque-out (N-m)	Pull Thru (N)
	M3	0.54	FHA	1.55 mm 5052-H34 Aluminum	74	10.7	575	0.5	1500
	M4	0.96	FHA	1.55 mm 5052-H34 Aluminum	75	14.3	775	1.35	2000
	M5	1.5	FHA	1.55 mm 5052-H34 Aluminum	75	15.2	900	2.6	2500
	M6	3.2	FHA	1.6 mm 5052-H34 Aluminum	75	24.5	1500	5.3	4500

PERFORMANCE DATA - FH4™ STUDS(2)

UNIFIED	Thread Code	Rec. Nut Tightening Torque (in. lbs.) ⁽¹⁾	Test Sheet Thickness and Material ⁽³⁾	Sheet Hardness HRB	Installation (lbs.)	Pushout (lbs.)	Torque-out (in. lbs.)	Pull Thru (lbs.)
	440	11	.060" Stainless Steel	87	9000	450	16	800
	632	22	.060" Stainless Steel	87	9500	540	27	1350
	832	35	.060" Stainless Steel	86	11200	780	58	1800
	032	51	.060" Stainless Steel	86	12000	800	95	2250
	0420	117	.062" Stainless Steel	88	23000	1600	156	3900

METRIC	Thread Code	Rec. Nut Tightening Torque (N-m) ⁽¹⁾	Test Sheet Thickness and Material ⁽³⁾	Sheet Hardness HRB	Installation (kN)	Pushout (N)	Torque-out (N-m)	Pull Thru (N)
	M3	1.3	1.5 mm Stainless Steel	87	40	2220	1.8	3500
	M4	3.8	1.5 mm Stainless Steel	86	50	3210	6.5	8000
	M5	6	1.5 mm Stainless Steel	86	53	3560	10.7	10000
	M6	11	1.6 mm Stainless Steel	88	100	4200	15.9	14900

PERFORMANCE DATA - FHP™ STUDS(2)

UNIFIED	Thread Code	Rec. Nut Tightening Torque (in. lbs.) ⁽¹⁾	Test Sheet Thickness and Material ⁽³⁾	Sheet Hardness HRB	Installation (lbs.)	Pushout (lbs.)	Torque-out (in. lbs.)	Pull Thru (lbs.)
	440	8.1	.045" Stainless Steel	86	9000	520	10.6	605
	632	16	.045" Stainless Steel	86	9500	670	19.5	940
	832	28	.045" Stainless Steel	86	11200	785	37.5	1415
	032	34	.045" Stainless Steel	86	12000	800	59.5	1500

METRIC	Thread Code	Rec. Nut Tightening Torque (N-m) ⁽¹⁾	Test Sheet Thickness and Material ⁽³⁾	Sheet Hardness HRB	Installation (kN)	Pushout (N)	Torque-out (N-m)	Pull Thru (N)
	M3	1.3	2 mm Stainless Steel	86	40	2500	1.6	3500
	M4	2.9	1.14 mm Stainless Steel	86	50	3000	3.9	6000
	M5	4.4	1.14 mm Stainless Steel	86	53	3560	7.35	7320

- (1) Tightening torque shown is a theoretical value calculated to induce a load of 75% of minimum axial yield strength of the stud with an assumed K value or nut factor equal to 0.20. In some applications tightening torque may need to be adjusted based on the actual K value.
- (2) Performance values shown are typical for fasteners properly installed using raised ring tooling in good condition. We recommend replacing installation tooling when the height of the "P" falls out of tolerance (see page 18). Reductions in performance may occur as the height of the protrusion wears. Variations in hole preparation, installation force, and sheet material type, thickness, and hardness will affect both performance and tooling life.
- (3) Performance may be reduced for studs installed into thicker sheets.



SELF-CLINCHING STUDS AND PINS

PERFORMANCE DATA - FHL™/FHLS™ STUDS

UNIFIED	Thread Code	Rec. Nut Tightening Torque (in. lbs.) ⁽¹⁾	Type	Test Sheet Thickness and Material	Sheet Hardness HRB	Installation (lbs.)	Pushout (lbs.)	Torque-out (in. lbs.)	Pull Thru (lbs.)	Pull Thru Test Bushing Hole Size (in.)
	256	2.1	FHL / FHLS	.047" Aluminum	33	700	55	4	230	.106
		3.8	FHL / FHLS	.045" Steel	54	1200	85	8	425	.106
	440	3.5	FHL / FHLS	.047" Aluminum	33	1000	60	5	300	.132
		6.8	FHL / FHLS	.045" Steel	54	1200	105	11	580	.132
	632	4.7	FHL / FHLS	.047" Aluminum	33	1000	65	6.5	325	.158
		9	FHL / FHLS	.045" Steel	54	1500	110	15	650	.158
	832	6	FHL / FHLS	.047" Aluminum	33	1200	80	9	350	.184
		13	FHL / FHLS	.045" Steel	54	1500	125	18	740	.184
	032	7.9	FHL / FHLS	.047" Aluminum	33	2500	115	18	395	.210
16		FHL / FHLS	.045" Steel	54	4500	210	38	800	.210	

METRIC	Thread Code	Rec. Nut Tightening Torque (N-m) ⁽¹⁾	Type	Test Sheet Thickness and Material	Sheet Hardness HRB	Installation (kN)	Pushout (N)	Torque-out (N-m)	Pull Thru (N)	Pull Thru Test Bushing Hole Size (mm)
	M2.5	0.32	FHL / FHLS	1.2 mm Aluminum	33	3.1	285	0.55	1200	3
		0.59	FHL / FHLS	1.1 mm Steel	54	5.3	450	1.1	2250	3
	M3	0.41	FHL / FHLS	1.2 mm Aluminum	33	4.4	285	0.65	1300	3.5
		0.79	FHL / FHLS	1.1 mm Steel	54	5.3	475	1.25	2500	3.5
	M3.5	0.51	FHL / FHLS	1.2 mm Aluminum	33	4.4	290	0.76	1400	4
		1.03	FHL / FHLS	1.1 mm Steel	54	6.6	500	1.75	2800	4
	M4	0.65	FHL / FHLS	1.2 mm Aluminum	33	5.3	365	1.1	1550	4.5
		1.39	FHL / FHLS	1.1 mm Steel	54	6.6	550	2.1	3300	4.5
	M5	0.97	FHL / FHLS	1.2 mm Aluminum	33	11.1	530	2.2	1850	5.5
1.97		FHL / FHLS	1.1 mm Steel	54	20	1000	4.4	3750	5.5	

PERFORMANCE DATA - TFH™/TFHS™ NON-FLUSH STUDS

UNIFIED	Thread Code	Max. Nut Tightening Torque (in. lbs.)	Type	Test Sheet Thickness and Material	Sheet Hardness HRB	Installation (lbs.) ⁽²⁾	Pushout (lbs.)	Torque-out (in. lbs.)
	440	5	TFH	.020" Aluminum	28	1300	45	7
			TFHS	.020" Aluminum	28	1200	45	7
			TFH	.023" Steel	52	2800	100	8
			TFHS	.023" Steel	52	1500	100	8
	632	9	TFH	.020" Aluminum	28	2100	50	8
			TFHS	.020" Aluminum	28	1500	50	8
			TFH	.023" Steel	52	2500	110	16
			TFHS	.023" Steel	52	2500	110	16
	832	17	TFH	.020" Aluminum	28	2100	60	10
TFHS			.020" Aluminum	28	2200	60	11	
TFH			.023" Steel	52	3100	120	26	
TFHS			.023" Steel	52	2700	120	26	
024	24	TFH	.020" Aluminum	28	2300	65	14	
		TFHS	.020" Aluminum	28	2500	65	14	
032	27	TFH	.023" Steel	52	3700	150	30	
		TFHS	.023" Steel	52	3000	130	28	

METRIC	Thread Code	Max. Nut Tightening Torque (N-m)	Type	Test Sheet Thickness and Material	Sheet Hardness HRB	Installation (kN) ⁽²⁾	Pushout (N)	Torque-out (N-m)
	M3	0.74	TFH	0.51 mm Aluminum	28	5.8	195	0.6
			TFHS	0.51 mm Aluminum	28	5.3	195	0.6
			TFH	0.58 mm Steel	52	12.5	300	1
			TFHS	0.58 mm Steel	52	6.7	300	1
	M4	1.7	TFH	0.51 mm Aluminum	28	12.5	250	0.7
			TFHS	0.51 mm Aluminum	28	9.8	250	0.7
			TFH	0.58 mm Steel	52	17.8	500	2.5
			TFHS	0.58 mm Steel	52	13.4	500	2.5
	M5	3.5	TFH	0.51 mm Aluminum	28	15.6	270	1.3
TFHS			0.51 mm Aluminum	28	13.4	270	1.3	
TFH			0.58 mm Steel	52	26.7	670	3	
TFHS			0.58 mm Steel	52	17.8	670	3	

(1) Tightening torque shown is a theoretical value calculated to induce a load of 75% of minimum axial yield strength of the stud with an assumed K value or nut factor equal to 0.20. In some applications tightening torque may need to be adjusted based on the actual K value.

(2) Installation controlled by proper cavity depth in punch.

SELF-CLINCHING STUDS AND PINS

PERFORMANCE DATA - HFE™ STUDS

UNIFIED	Thread Code	Rec. Nut Tightening Torque (ft. lbs.) ⁽¹⁾	Test Sheet Thickness and Material (in.)	Sheet Hardness HRB	Installation (lbs.) ⁽²⁾	Pushout (lbs.)	Torque-out (in. lbs.)	Tensile Strength (lbs.) ⁽³⁾	Pull Thru (lbs.)	Test Bushing Hole Size For Pull Thru Tests
	032	3.6	.040" Aluminum	27	7500	170	60	2400	1900	.279
4.2		.040" Cold-rolled Steel	67	9500	300	60	2400	2200		
0420	8	.040" Aluminum	27	8000	180	120	3820	3200	.335	
	9	.040" Cold-rolled Steel	67	13500	340	130	3820	3600		
0518	19	.060" Aluminum	22	9000	275	240	6280	6000	.407	
	20	.060" Cold-rolled Steel	65	15500	575	290	6280	6400		

METRIC	Thread Code	Rec. Nut Tightening Torque (N-m) ⁽¹⁾	Test Sheet Thickness and Material (mm)	Sheet Hardness HRB	Installation (kN) ⁽²⁾	Pushout (N)	Torque-out (N-m)	Tensile Strength (kN) ⁽³⁾	Pull Thru (kN)	Test Bushing Hole Size For Pull Thru Tests
	M5	5.8	1 mm Aluminum	27	37.7	690	8.1	12.8	9.7	7.4
6.4		1 mm Cold-rolled Steel	67	51.1	1350	8.1	12.8	10.6		
M6	10	1 mm Aluminum	27	39	750	11.8	18.1	14.2	8.2	
	11	1 mm Cold-rolled Steel	67	60	1400	14.4	18.1	15.5		
M8	24	1.5 mm Aluminum	22	42	1230	23.5	32.9	25	10.3	
	26	1.5 mm Cold-rolled Steel	65	71.1	2400	33.9	32.9	27.5		

PERFORMANCE DATA - THFE™ STUDS

UNIFIED	Thread Code	Rec. Nut Tightening Torque (ft. lbs.) ⁽¹⁾	Test Sheet Thickness and Material (in.)	Sheet Hardness HRB	Installation (lbs.) ⁽²⁾	Pushout (lbs.)	Torque-out (in. lbs.)	Tensile Strength (lbs.) ⁽³⁾	Pull Thru (lbs.)	Test Bushing Hole Size For Pull Thru Tests
	0420	8.1	.031" Aluminum	35	8800	116	71	3820	3249	.340
8.5		.031" Cold-rolled Steel	47	13500	197	116	3820	3388		
0518	18	.031" Aluminum	44	11700	131	103	6280	5701	.402	
	18	.031" Cold-rolled Steel	47	16000	187	124	6280	5772		

METRIC	Thread Code	Rec. Nut Tightening Torque (N-m) ⁽¹⁾	Test Sheet Thickness and Material (mm)	Sheet Hardness HRB	Installation (kN) ⁽²⁾	Pushout (N)	Torque-out (N-m)	Tensile Strength (kN) ⁽³⁾	Pull Thru (kN)	Test Bushing Hole Size For Pull Thru Tests
	M6	9	0.8 mm Aluminum	38	39.2	550	7.3	18.1	13	8.3
10		0.8 mm Cold-rolled Steel	47	60.1	886	13.4	18.1	14.3		
M8	27	0.8 mm Aluminum	44	56	582	12.2	32.9	27.8	10.3	
	27	0.8 mm Cold-rolled Steel	47	71.2	881	13.1	32.9	28.1		

(1) Tightening torque shown is a theoretical value calculated to induce a load of 75% of minimum axial yield strength of the stud with an assumed K value or nut factor equal to 0.20. In some applications tightening torque may need to be adjusted based on the actual K value.

(2) Installation controlled by proper cavity depth in punch.

(3) Head size is adequate to ensure failure in threaded area.



SELF-CLINCHING STUDS AND PINS

PERFORMANCE DATA - HFH™/HFHS™/HFHB™ STUDS

UNIFIED	Thread Code	Type	Rec. Nut Tightening Torque (ft. lbs.) (1)	Test Sheet Thickness and Material	Sheet Hardness HRB	Installation (lbs.) (2)	Pushout (lbs.)	Torque-out (ft. lbs.)	Tensile Strength (lbs.)
	032	HFH	4.6	.060" Aluminum	15	3000	180	4	2400
		HFH	4.6	.060" Steel	65	6000	375	5	2400
		HFHS	2.5	.050" Aluminum	38	3000	180	4	1500
		HFHS	2.5	.058" Steel	52	4500	325	4	1500
	0420	HFHB	1.7	.061" Copper CDA-110	28	3400	150	2.9	1200
		HFH	9.6	.060" Aluminum	43	5500	285	11	3820
		HFH	9.6	.060" Steel	59	7000	480	11	3820
		HFHS	5.2	.064" Aluminum	32	4000	285	8	2385
	0518	HFHS	5.2	.072" Steel	43	6500	480	8	2385
HFHB		3.6	.061" Copper CDA-110	28	6000	380	5	1908	
HFH		20	.091" Aluminum	39	8000	380	22	6280	
HFH		20	.090" Steel	58	10000	590	22	6280	
0616	HFHS	11	.087" Aluminum	41	5500	380	15	3930	
	HFHS	11	.099" Steel	44	7500	590	15	3930	
	HFHB	7	.126" Copper CDA-110	32	7500	500	11	3140	
	HFH	35	.091" Aluminum	39	12000	550	25	9300	
0616	HFH	35	.090" Steel	58	16000	780	36	9300	
	HFHS	19	.123" Aluminum	44	10000	560	25	5810	
	HFHS	19	.099" Steel	44	13000	780	25	5810	
	HFHB	13	.126" Copper CDA-110	32	12000	560	18	4650	

METRIC	Thread Code	Type	Rec. Nut Tightening Torque (N-m) (1)	Test Sheet Thickness and Material	Sheet Hardness HRB	Installation (kN) (2)	Pushout (N)	Torque-out (N-m)	Tensile Strength (kN)
	M5	HFH	7.7	1.5 mm Aluminum	15	13	800	5.4	12.8
		HFH	7.7	1.5 mm Steel	65	26	1500	7.6	12.8
		HFHS	3.8	1.62 mm Aluminum	35	12.4	800	5.4	7.3
		HFHS	3.8	1.47 mm Steel	54	21.7	1500	6.4	7.3
	M6	HFHB	2.7	1.5 mm Copper CDA-110	28	15.6	1115	3.4	5.9
		HFH	13	1.5 mm Aluminum	43	29	1270	14	18.1
		HFH	13	1.5 mm Steel	59	33	1750	14	18.1
		HFHS	6.5	1.62 mm Aluminum	35	15.4	1270	11	10.3
	M8	HFHS	6.5	1.6 mm Steel	45	24.6	1750	11	10.3
HFHB		4.5	1.5 mm Copper CDA-110	28	25.3	1600	6.7	8.3	
HFH		32	2.3 mm Aluminum	39	35.6	1700	30	32.9	
HFH		32	2.3 mm Steel	58	44.5	2200	30	32.9	
M10	HFHS	16	2.23 mm Aluminum	44	24.4	1700	20	18.8	
	HFHS	16	2.48 mm Steel	43	37.8	2100	20	18.8	
	HFHB	11	3.2 mm Copper CDA-110	32	33	2250	15.3	15.1	
	HFH	63	2.3 mm Aluminum	39	53.3	2445	36	52.2	
M10	HFH	63	2.3 mm Steel	58	71.2	3470	49	52.2	
	HFHS	31	2.3 mm Aluminum	44	44.4	2445	36	29.9	
	HFHS	31	2.3 mm Steel	44	57.7	3470	36	29.9	
	HFHB	22	3.2 mm Copper CDA-110	32	53.3	2500	25	24	

PERFORMANCE DATA - HFG8™/HF109™ HIGH TENSILE STRENGTH STUDS

UNIFIED	Thread Code	Rec. Nut Tightening Torque (ft. lbs.)	Tensile Strength (lbs.) (3)	Test Sheet Material	Sheet Hardness HRB	Installation (lbs.) (2)	Pushout (lbs.)	Torque-out (ft. lbs.)	Test Sheet Material	Sheet Hardness HRB	Installation (lbs.) (2)	Pushout (lbs.)	Torque-out (ft. lbs.)
	032	6.4	3000	.047" HSLA Steel	85.5	14000	483	6.2	.040" Cold-rolled Steel	45.0	9900	249	5.9
	0420	13	4750	.047" HSLA Steel	85.7	21400	592	11.5	.040" Cold-rolled Steel	45.0	14100	248	11.5
	0518	28	7850	.060" HSLA Steel	84.9	32600	667	25.6	.060" Cold-rolled Steel	55.2	19100	447	25.2

METRIC	Thread Code	Rec. Nut Tightening Torque (N-m)	Tensile Strength (kN) (3)	Test Sheet Material	Sheet Hardness HRB	Installation (kN) (2)	Pushout (N)	Torque-out (N-m)	Test Sheet Material	Sheet Hardness HRB	Installation (kN) (2)	Pushout (N)	Torque-out (N-m)
	M5	10	14.8	1.2 mm HSLA Steel	86.1	60.1	2084	9	1 mm Cold-rolled Steel	45.3	43.2	978	9
	M6	17	20.9	1.2 mm HSLA Steel	85.6	90	2454	15.6	1 mm Cold-rolled Steel	45.5	60	1072	14.4
	M8	41	38.1	1.5 mm HSLA Steel	84	145	3026	38.4	1.5 mm Cold-rolled Steel	55	85	1992	37.7

(1) Tightening torque shown is a theoretical value calculated to induce a load of 75% of minimum axial yield strength of the stud with an assumed K value or nut factor equal to 0.20. In some applications tightening torque may need to be adjusted based on the actual K value.

(2) Installation controlled by proper cavity depth in punch.

(3) Head size is adequate to ensure failure in threaded area.



SELF-CLINCHING STUDS AND PINS

PERFORMANCE DATA - HFLH™ STUDS

UNIFIED	Thread Code	Rec. Nut Tightening Torque (ft. lbs.) (1)	Test Sheet Thickness and Material (in.)	Sheet Hardness HRB	Installation (lbs.) (2)	Pushout (lbs.)	Torque-out (in. lbs.)	Tensile Strength (lbs.) (3)	Pull Thru (lbs.)	Test Bushing Hole Size For Pull Thru Tests
	032	4.2	.040" HC500LA	89	9500	300	60	2400	2200	.279
	0420	10	.040" HC500LA	89	13500	340	130	3820	3600	.335
	0518	23	.060" HC500LA	91	16000	575	290	6280	6400	.407

METRIC	Thread Code	Rec. Nut Tightening Torque (N-m) (1)	Test Sheet Thickness and Material (mm)	Sheet Hardness HRB	Installation (kN) (2)	Pushout (N)	Torque-out (N-m)	Tensile Strength (kN) (3)	Pull Thru (kN)	Test Bushing Hole Size For Pull Thru Tests
	M5	6.4	1 mm HC500LA	89	51.1	1350	8.1	12.8	10.6	7.4
	M6	11	1 mm HC500LA	89	60	1400	14.4	18.1	15.5	8.2
	M8	26	1.5 mm HC500LA	91	71.1	2400	33.9	32.9	27.5	10.3

PERFORMANCE DATA - SGPC™ SWAGING COLLAR STUDS

UNIFIED	Thread Code	Rec. Nut Tightening Torque (in. lbs.) (1)	Test Sheet Material			
			Single sheet of .039" 300 Series Stainless Steel			
			Installation (lbs.)	Pushout (lbs.)	Torque-out (in. lbs.)	Pull-thru (lbs.)
	256	3.7	4000	425	5.2	415
440	6	5000	450	8	512	
632	12	5500	460	15.8	811	
832	20	6500	480	29.3	1133	
032	25	7300	545	42.8	1273	
0420	45	10000	565	76.7	1721	

METRIC	Thread Code	Rec. Nut Tightening Torque (N-m) (1)	Test Sheet Material			
			Single sheet of 1 mm 300 Series Stainless Steel			
			Installation (kN)	Pushout (N)	Torque-out (N-m)	Pull-thru (N)
	M2.5	0.67	20.1	2546	0.86	2561
M3	0.9	21.8	2051	1.35	2851	
M4	2.5	28.5	2396	2.66	4000	
M5	3.3	35.6	3200	5.96	4284	
M6	3.3	42.3	3262	9.19	6311	

PERFORMANCE DATA - FHX™ STUDS WITH X-PRESS™ THREAD PROFILE

Thread Code	Test Sheet Material (4)	Installation kN	Pushout N	Torque-out N-m
X5	1.1 mm Steel HRB 58 / HB 104	24.9	1519	4.7
	1.2 mm Aluminum HRB 44 / HB 66	19.2	1070	3.2
X6	1.6 mm Steel HRB 58 / HB 104	35.6	2964	13.3
	1.6 mm Aluminum HRB 44 / HB 66	29.4	1623	7

- (1) Tightening torque shown is a theoretical value calculated to induce a load of 75% of minimum axial yield strength of the stud with an assumed K value or nut factor equal to 0.20. In some applications tightening torque may need to be adjusted based on the actual K value.
- (2) Installation controlled by proper cavity depth in punch.
- (3) Head size is adequate to ensure failure in threaded area when tested with industry standard tensile bushing diameter.
- (4) HRB - Hardness Rockwell "B" Scale, HB - Hardness Brinell.



SELF-CLINCHING STUDS AND PINS

PERFORMANCE DATA - TPS™ PILOT PINS

UNIFIED	Pin Dia. Code	Test Sheet Material	Sheet Hardness HRB	Installation (lbs.)	Pushout (lbs.)
	125	Aluminum	20	4500	150
Steel		62	6500	250	
187	Aluminum	18	6500	230	
	Steel	60	8000	400	
250	Aluminum	18	7000	270	
	Steel	62	9000	500	

METRIC	Pin Dia. Code	Test Sheet Material	Sheet Hardness HRB	Installation (kN)	Pushout (kN)
	3MM	Aluminum	22	12	0.56
Steel		65	22	0.98	
4MM	Aluminum	19	22	0.89	
	Steel	66	26.4	1.54	
5MM	Aluminum	18	28.6	1.01	
	Steel	60	35.2	1.76	
6MM	Aluminum	18	30.8	1.1	
	Steel	62	39.6	2.1	

PERFORMANCE DATA - TP4™ PILOT PINS

UNIFIED	Pin Dia. Code	Test Sheet Material	Installation (lbs.)	Pushout (lbs.)
	125	300 Series Stainless Steel	8000	350
187	300 Series Stainless Steel	12000	570	
250	300 Series Stainless Steel	14000	650	

METRIC	Pin Dia. Code	Test Sheet Material	Installation (kN)	Pushout (N)
	3MM	300 Series Stainless Steel	35	1556
4MM	300 Series Stainless Steel	45	2335	
5MM	300 Series Stainless Steel	54	2535	
6MM	300 Series Stainless Steel	60	2891	

PERFORMANCE DATA - TPXS™ PILOT PINS

METRIC	Pin Dia. Code	Test Sheet Material	Sheet Hardness HRB	Installation (kN)	Pushout (kN)
	3MM	Aluminum	22	12	0.56
Steel		65	22	0.98	

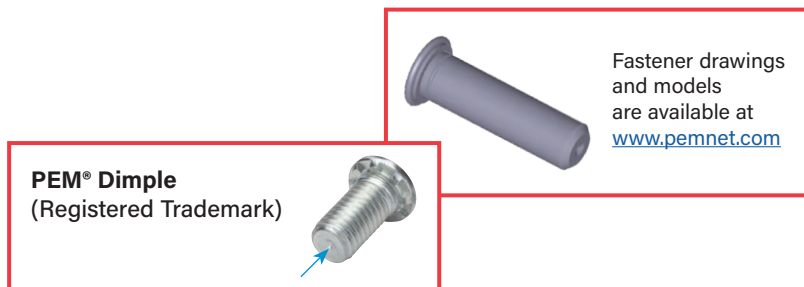

All PEM® products meet our stringent quality standards. If you require additional industry or other specific [quality certifications](#), special procedures and/or part numbers are required. Please contact your local sales office or representative for further information.

Regulatory [compliance information](#) is available in Technical Support section of our website. Specifications subject to change without notice. See our website for the most current version of this bulletin.

PennEngineering®



North America: Danboro, Pennsylvania USA • E-mail: info@pemnet.com • Tel: +1-215-766-8853 • 800-237-4736 (USA)

Europe: Galway, Ireland • E-mail: europa@pemnet.com • Tel: +353-91-751714

Asia/Pacific: Singapore • E-mail: singapore@pemnet.com • Tel: +65-6-745-0660

Shanghai, China • E-mail: china@pemnet.com • Tel: +86-21-5868-3688

Visit our PEMNET™ Resource Center at www.pemnet.com • Technical support e-mail: techsupport@pemnet.com