

## About

The BRITEX Accessible Bellagio Wash Basin is a fully hand made, double-skinned stainless steel wash basin. Manufactured from heavy gauge commercial grade stainless steel, the Accessible Bellagio wash basin is supplied complete with a 40mm waste outlet and is both functional and robust.

Designed with a larger back landing that meets AS1428.1 shelf requirements allows for the basin to be compliant without an additional shelf unit. For design flexibility the landing is also available to the left or right of the basin.

*The Accessible Bellagio Basin is designed to be wall mounted.*

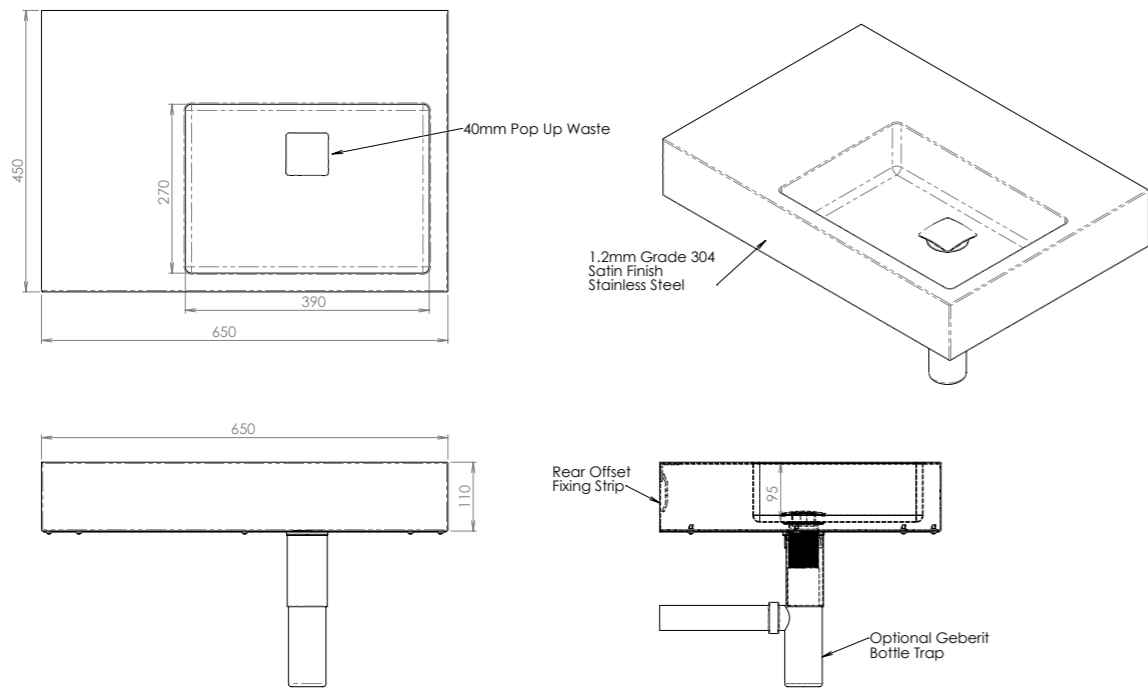

**Fig 1: HBBEL-D Drawing**

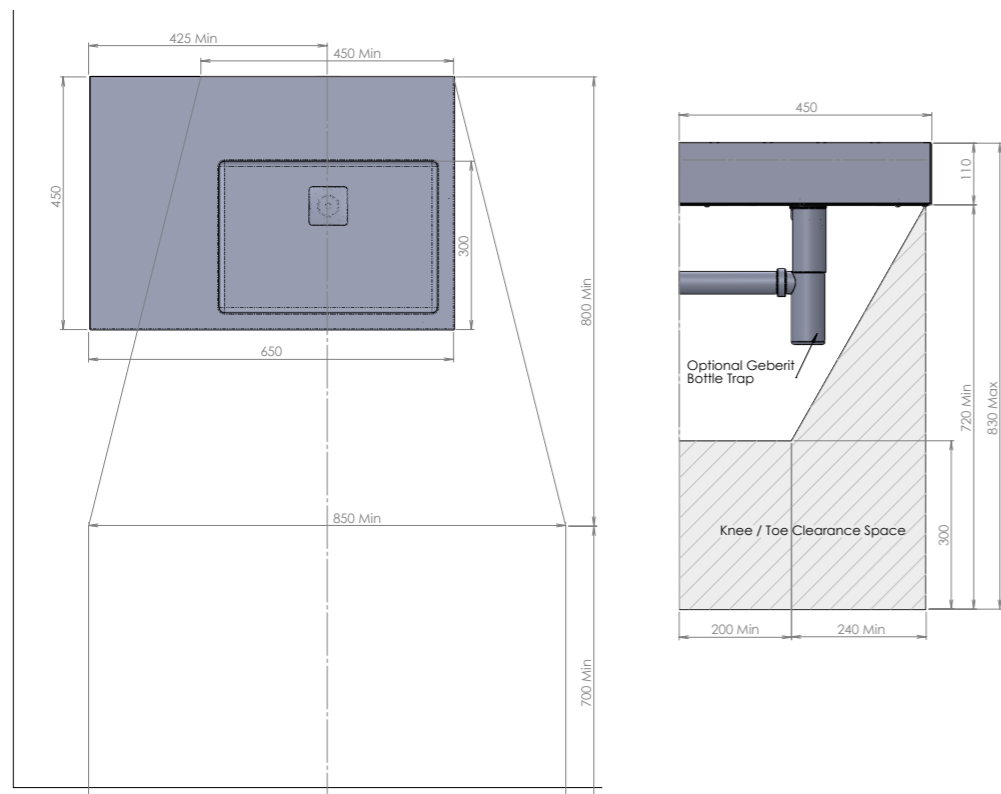
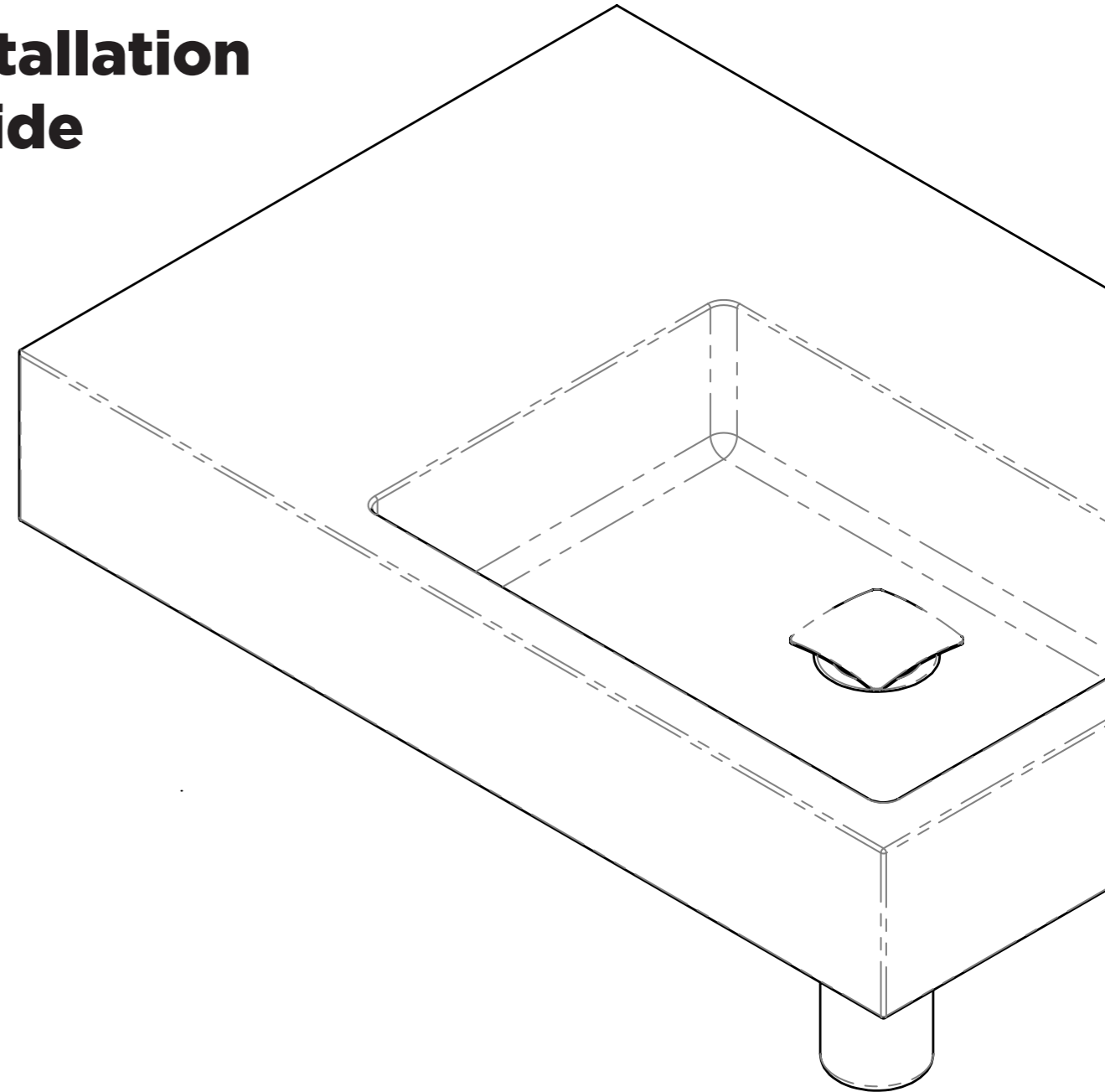

**Fig 2: AS1428 Clearance Diagram**

## HBBEL-DS

### Accessible Bellagio Basins (with integrated Shelf)

## Installation Guide



**MELBOURNE**  
Britex Place Mirra Crt  
Bundoora VIC 3083  
t (03) 9466 9000  
e vic@britex.com.au

**SYDNEY**  
16 Northumberland Drv  
Taren Point NSW 2229  
t (02) 9531 2100  
e nsw@britex.com.au

**PERTH**  
Unit 1/8 Principal Link  
Malaga WA 6090  
t (08) 9249 5464  
e wa@britex.com.au

**BRISBANE**  
19 Manilla St  
East Brisbane QLD 4169  
t (07) 3363 2400  
e qld@britex.com.au

**ADELAIDE**  
The Britex Group  
SA State Office  
t 1300 764 744  
e sa@britex.com.au

## Installation Guide

1. Check box to ensure all components have been included and are in good condition.
2. Ensure the provided noggins have been fixed to the required height of 720mm tp 830mm AFFL.
3. Provide 40mm waste rough in point to required height dependant on make and model of trap being used.
4. Provide 1/2" water supply @ 740 - 780mm AFFL.
5. Mark wall to top of basin height of 830mm AFFL in the location the basin is to be installed.
6. With wall bracket in place on basin, measure and note the fixing hole ppint height and copy to wall.
7. Fix mounting bracket to wall with appropriate screws or sleeve anchors as required.
8. Mount basin to wall bracket and fix to mounting bracket.
9. Fit tapware and connect water.
10. Fit plug and washer to basin (do not connect to waste)
11. Fit cover to underside.
12. Connect waste to 40mm plug and washer.

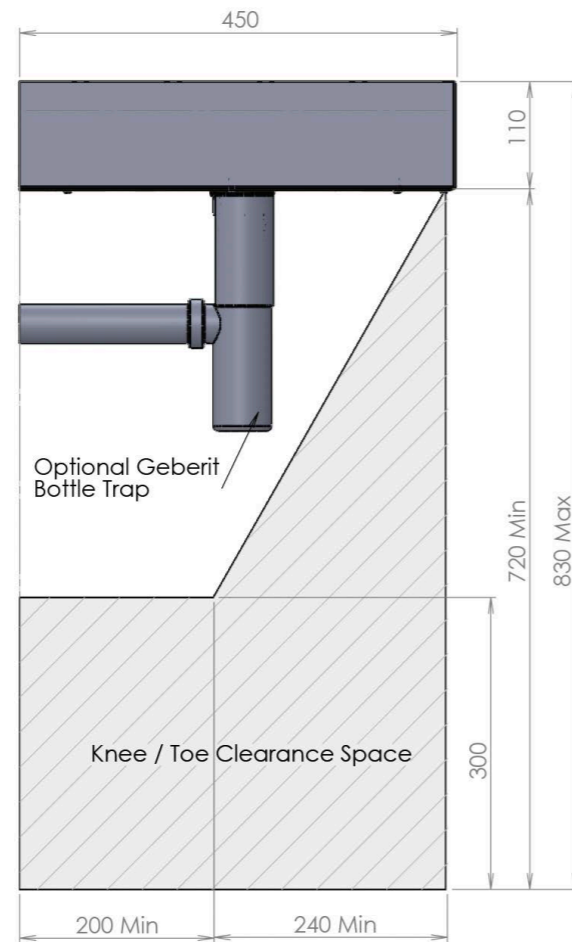

NOTE: This Basin Must Be Fixed Directly To A Stud/Noggin Or Masonary Wall

## Assembly Diagram

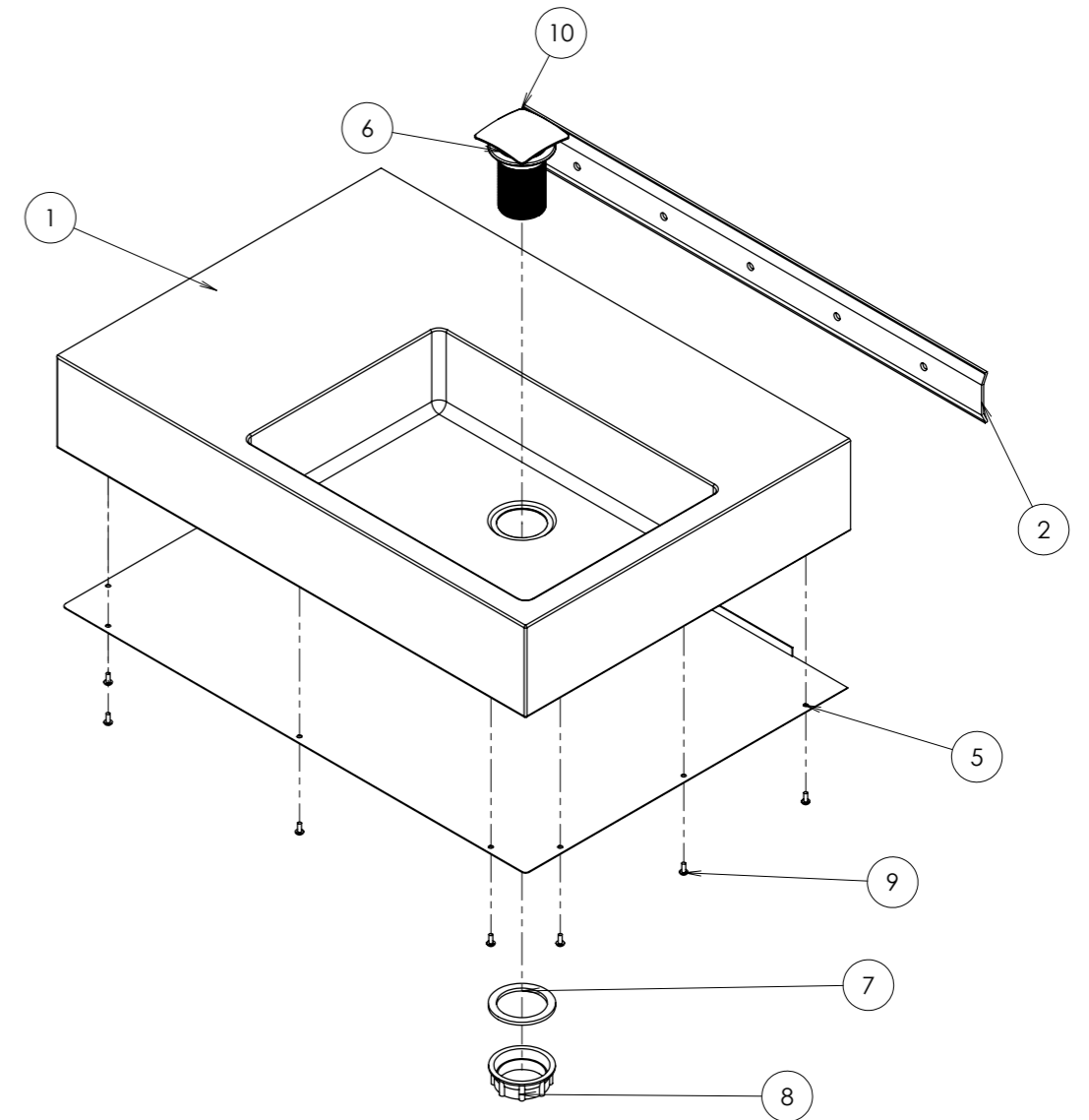

ITEM NO.	PART NUMBER	DESCRIPTION	QTY.
1	50-03-0034		1
2	50-03-0034 Joggle		1
4	M4 Riv NutSL		9
5	HBBEL BaseSL		1
6	40X70 WasteSL		1
7	40X70 Waste WasherSL		1
8	40X70 Waste NutSL		1
9	M4 X 10 Button Head Allen ScrewSL		9
10	Pop Up topSL		1

Fig 3: Assembly Diagram