

AQ3ND SENSOR

Nitrogen Dioxide (NO₂) Gas Sensor

The purpose of this document is to present the performance specification of the AQ3 Series AQ3ND Nitrogen Dioxide Gas Sensor.

DOCUMENT PURPOSE

This document should be used in conjunction with the AQ3ND Characterization Note and the Product Safety Datasheet (PSDS 5).

The data provided in this document is based on the assumption that the sensor is used at 20°C, 50% rH, and 1013 mBar for three months from the date of sensor manufacture. For guidance on sensor performance outside of these limits, please refer to the AQ3ND Characterization Note.

Output signal can drift below the lower limit over time. For guidance on the safe use of the sensor, please refer to the Characterization Note.



Sensor Part Number (without board):
AGQ004-300

Module Part Number (with board):
QAG004-300

PCBA Part Number: AQ3-BP02

FEATURES AND BENEFITS



High resolution



Low detection limit



Custom-built low noise board achieves high accuracy under ppb level



Individual compensation for temperature and cross sensitivity



High correlation with control station

AQ3ND Nitrogen Dioxide Gas Sensor Technical Specifications

TECHNICAL SPECIFICATIONS

MEASUREMENT	
Technology	4-electrode electrochemical
Measurement Range	0 ppm NO ₂ to 1 ppm NO ₂
Maximum Overload	without board: 5 ppm NO ₂ with board: 1.5 ppm NO ₂
Onboard Filter	to remove Ozone
Sensitivity*	without board: 2300 nA/ppm ±500 nA/ppm with board: 1700 mV/ppm ±500 mV/ppm
Response Time (T₉₀)	≤ 120 seconds
Resolution*	10 ppb when used with recommended circuitry
Baseline Offset*	without board: ≤ ±200 nA with board: ≤ ±160 mV
Repeatability*	< ±2% of signal
Linearity**	linear
Low Detection Limit*	10 ppb
ELECTRICAL	
Recommended Load Resistor	68 Ω
Sensor Bias Voltage	no bias (without board)
Power Supply Required	5 Vdc (with board)
Power Consumption	350 μA @ 5 Vdc (with board)
MECHANICAL	
Weight	without board: < 22 g with board: < 30 g
Outer Plastic Body Material	polycarbonate
Sealing Gasket Material	TPU
Contact Material	mild steel with gold flash-over nickel plate
Orientation Sensitivity	none
ENVIRONMENTAL	
Operating Temperature Range	-30°C to 50°C
Recommended Storage Temperature	0°C to 20°C in original sealed container
Operating Humidity Range	15% rH to 90% rH non-condensing
Operating Pressure Range	atmospheric ±10%
Typical Applications	ambient environmental monitoring
LIFETIME	
Storage Life	6 months in original sealed container
Long-Term Sensitivity Drift*	< 10% signal loss per annum
Expected Oper. Life	two years in air
Warranty	one year

*Specifications are valid at 20°C, 50% RH, and 1013 mbar using AQ3 low noise board. Performance characteristics outline the performance of sensors supplied within the first 3 months. Output signal can drift below the lower limit over time. Please be aware that sensors' performance also reflected by circuit board design.

** Linear through the concentration range across the whole operational environment range.

Product Dimensions

Dimensions mm.

All tolerances ±0,15 mm unless otherwise stated

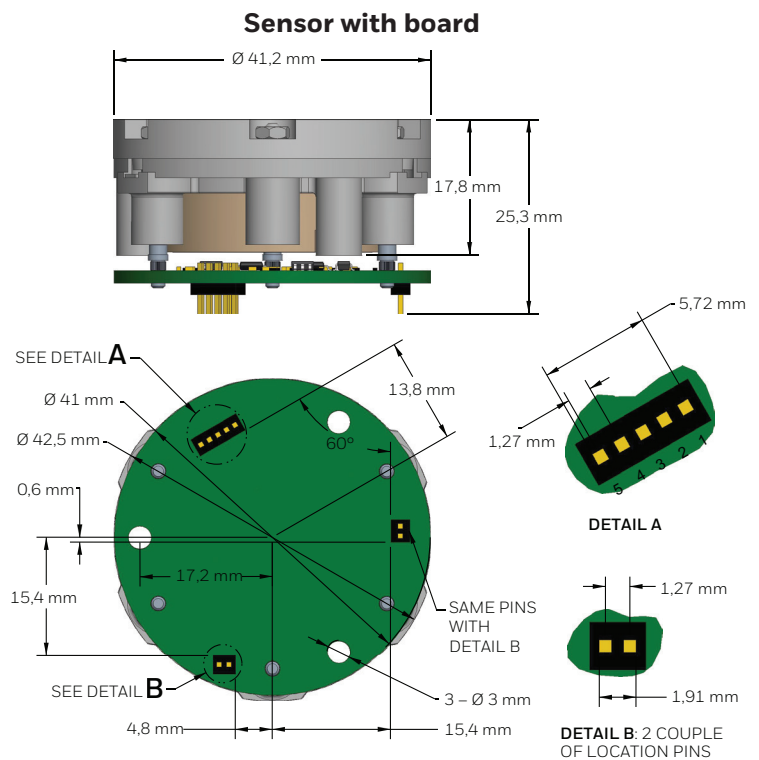
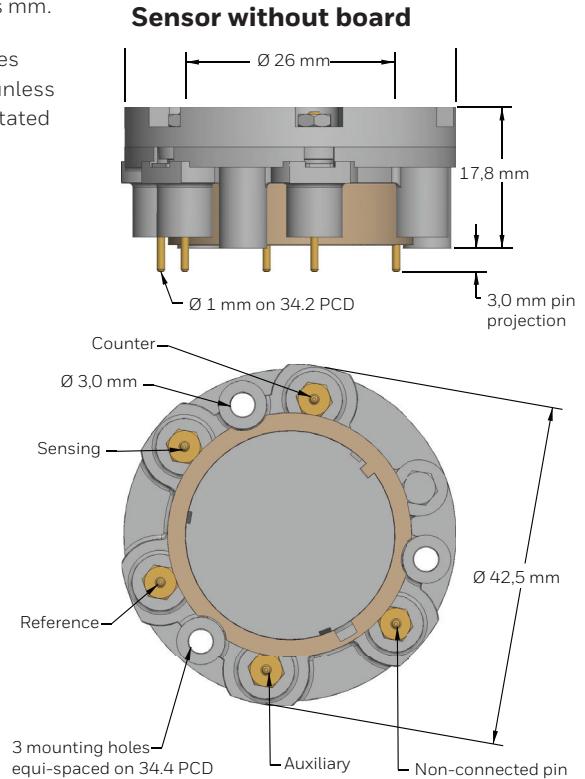

Pin Definition

1	Vin (4.8 V ~ 5.5 V)
2	GND
3	Aux
4	GND
5	Sensing

AQ3ND Nitrogen Dioxide Gas Sensor Technical Specifications

Filter Information

Removes Ozone

Poisoning

Gas sensors are designed for operation in a wide range of environments and harsh conditions. However, it is important that exposure to high concentrations of solvent vapors is avoided, during storage, fitting into instruments, and operation.

When using sensors with printed circuit boards (PCBs), degreasing agents should be used before the sensor is fitted.

Do not glue directly on or near the sensor as the solvent may cause crazing of the plastic.

Cross Sensitivity Table

Whilst AQ3 Series gas sensors are designed to be highly specific to the gas they are intended to measure, they will still respond to some degree to various other gases.

The table below is not exclusive and other gases not included in the table may still cause a sensor to react.

IMPORTANT NOTE: The cross sensitivity data shown below does not form part of the product specification and is supplied for guidance only. Values quoted are based on tests conducted on a small number of sensors and any batch may show significant variation. For the most accurate measurements, an instrument should be calibrated using the gas under investigation.

Gas	Gas Concentration	Cross Interference
Carbon Monoxide (CO)	5 ppm	-2%<x%<0
Sulfur Dioxide (SO ₂)	5 ppm	-1%<x%<0
Ozone (O ₃)	1 ppm	~None
Isobutylene (C ₄ H ₈)	1 ppm	~None

WARRANTY/REMEDY

Honeywell warrants goods of its manufacture as being free of defective materials and faulty workmanship during the applicable warranty period. Honeywell's standard product warranty applies unless agreed to otherwise by Honeywell in writing; please refer to your order acknowledgment or consult your local sales office for specific warranty details. If warranted goods are returned to Honeywell during the period of coverage, Honeywell will repair or replace, at its option, without charge those items that Honeywell, in its sole discretion, finds defective. **The foregoing is buyer's sole remedy and is in lieu of all other warranties, expressed or implied, including those of merchantability and fitness for a particular purpose. In no event shall Honeywell be liable for consequential, special, or indirect damages.**

While Honeywell may provide application assistance personally, through our literature and the Honeywell web site, it is buyer's sole responsibility to determine the suitability of the product in the application.

Specifications may change without notice. The information we supply is believed to be accurate and reliable as of this writing. However, Honeywell assumes no responsibility for its use.

FOR MORE INFORMATION

Honeywell Advanced Sensing Technologies services its customers through a worldwide network of sales offices and distributors. For application assistance, current specifications, pricing or the nearest Authorized Distributor, visit [our website](#) or call:

USA/Canada	+1 302 613 4491
Latin America	+1 305 805 8188
Europe	+44 1344 238258
Japan	+81 (0) 3-6730-7152
Singapore	+65 6355 2828
Greater China	+86 4006396841

Honeywell Advanced Sensing Technologies

830 East Arapaho Road
Richardson, TX 75081
www.honeywell.com

WARNING MISUSE OF DOCUMENTATION

- The information presented in this product sheet is for reference only. Do not use this document as a product installation guide.
- Complete installation, operation, and maintenance information is provided in the instructions supplied with each product.

Failure to comply with these instructions could result in death or serious injury.

SAFETY NOTE

This sensor is designed to be used in environmental applications. To ensure that the sensor and/or instrument in which it is used, are operating properly, it is a requirement that the function of the device is confirmed by exposure to target gas (bump check) before each use of the sensor and/or instrument. Failure to carry out such tests may jeopardize the safety of people and property.