

Vertical Air Receivers

McMillan offers a popular range of vertical air receivers that are specifically designed for use in industrial compressed air systems. These premium quality pressure vessels are exclusively made in our affiliated factory that is ISO 9001 compliant.

Save time and money when purchasing a vertical air receiver by selecting from our extensive stock of competitively priced pressure vessels that are available for immediate delivery anywhere in Australia.



- ◆ Design safety verified in accordance with Australian Standard AS1210-2010.
- ◆ Manufacturer's Data Report available, in accordance with Australian Standard AS4458-1997.
- ◆ OH&S Registered Design approved for workplace use in all Australian States and Territories.
- ◆ Industry preferred socket stand placement. Reinforced vessel support attachments.
- ◆ External surfaces are abrasive blast cleaned, primed and finish coated in two-pack polyurethane paint.
- ◆ Dulux® Process Blue external colour indicates compressed air content in accordance with Australian Standard AS1345-1995.
- ◆ Individually packed in a horizontal position inside a full timber crate with plastic bag cover.
- ◆ Design optimised for ease of handling, transport, storage and installation.

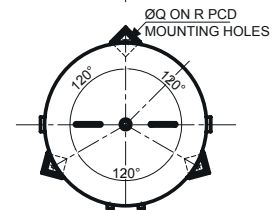
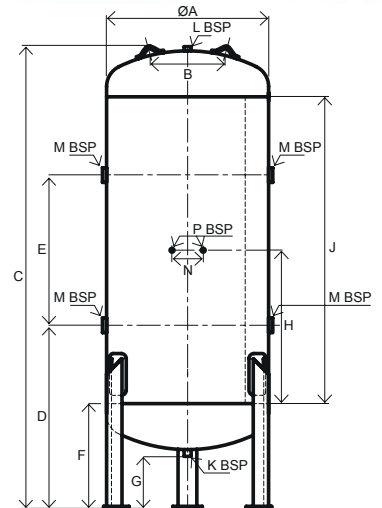

PRODUCT CODE	VOLUME	DESIGN PRESSURE		DIMENSIONS															WEIGHT	
				A	B	C	D	E	F	G	H	J	K	L	M	N	P	Q		R
				Litres	kPa	psi	mm	mm	mm	mm	mm	mm	mm	mm	mm	inch	inch	inch		mm
T60-V	60	1,485	215	325		1,115	515	350	365	249		650	1/2	3/4					300	33
T150-V	150	1,235	179	390	214	1,700	750	450	375	254	620	1,200	1/2	3/4	1-1/2	150	1/2	14	388	68
T300-V	300	1,215	176	490	250	2,040	755	780	405	254	800	1,480	1/2	3/4	1-1/2	150	1/2	14	505	126
T530-V	530	1,215	176	640	300	2,140	820	750	445	254	750	1,500	1/2	3/4	2	150	1/2	14	645	205
T820-V	820	1,220	177	780	360	2,215	875	720	500	250	735	1,470	3/4	3/4	2	150	1/2	18	785	415
T1240-V	1,240	1,100	160	975	500	2,213	889	690	514	245	720	1,440	3/4	1	2	150	3/4	18	967	468

Design temperature range: 0°C to 100°C.
 Design fluid contents: Non harmful gas.
 Inspection openings and nameplate not shown for clarity.
 All socket threads are BSPP (British Standard Pipe Parallel).

For improved air quality please consider our Refrigerated Dryers and Filters.