

Trouble Shooting Guide

PLEASE NOTE: A SERVICE CHARGE WILL BE MADE IF A SERVICE CALL IS REQUIRED TO ATTEND TO A FAULTY OR CARELESS INSTALLATION.

FOLLOW THIS PROCEDURE CAREFULLY.

Once it is established that the unit has not been damaged at installation, first, turn the power to the unit off & then back on.

Q. Does the water flow at all?

A. If the unit appears stuck on and water runs continuously where it has not been activated by passing the hand to wave it on and will not turn off by waving your hand past the lens;

I. Turn the power off.

If water continues to flow then the solenoid valve is at fault. It may be installed around the wrong way or have debris under the seat. Check that the valve is installed correctly for supply. If OK, consider taking the valve apart & check for debris under the plunger & diaphragm etc. Contact your distributor for advice.

Or If flow stops, check the sensor unit.

A. If there is no flow when a hand is waved past close to the sensor lens;

I. Check the power point is good and that the power is on.

II. Check the water supply cock/s is on.

III. Place the palm of your hand directly in front & parallel to the front face of the sensor, about 10 cm away. Move your hand slowly towards the sensor, keeping the palm of the hand flat, directly in front & parallel to the front face of the sensor. If the unit fails to operate even when brought up onto the sensor replace the sensor unit.

IV. Replace the Power Pack (Power pack failures are rare).

A. Occasionally;

I. The sensor may have become insensitive and be difficult to operate. If it will operate when a flat surface eg. white paper is passed very close to it, directly in front and parallel with the lenses, but not a moving hand, then replace the sensor unit.

In the event that on site trouble shooting does not clear or rectify any problems that you are experiencing, then it may be necessary to return the unit for appraisal and corrective action. Feedback from the field is important to enable us to improve and refine the product.

Once you have an understanding of what the problem is, contact your distributor or Trade Store to enable a quick resolve of these issues.

All parts are proudly manufactured and assembled in Australia and distributed by the Britex Group.

Care and Maintenance

Stainless steel products should be kept clean at all times. The secret to stainless steel's ability to maintain a high quality finish and promises of a long life expectancy is the invisible chromium-oxide film that sits on the surface and protects the steel beneath. To maintain this film it is essential that the surface remains clean and in constant contact with oxygen. If this film is penetrated (either by abrasion or chemically) and dirt, liquid, grime contaminants embed themselves in these micro chasms for an extended period of time, the chromiumoxide film will not be able to regenerate and the steel below will eventually become damaged and discoloured.

What we recommend for general cleaning and maintenance:

Cleaning Materials:

- A soft cloth
- A soft-bristled brush
- A natural or artificial sponge

Cleaning Solutions:

- Hand washing soap / soft water solution
- Mild soap / soft water solution
- White vinegar / soft water solution

It is recommended that general cleaning of stainless steel surfaces be carried out weekly, or as soon as a build up of surface media has been observed. To clean, simply wash stainless steel surfaces with, warm, diluted, mild soapy water using a cloth or soft bristled brush. Once all dirt, oil and grime is removed, rinse thoroughly with clean water and wipe dry

Do NOT - use a metal brush or steel wool to clean stainless steel. Ever. These tools will scratch the surface as well as potentially leave behind steel fragments that can go rusty and cause the stainless to discolour. Using these materials will void the warranty.

Do NOT - use scourers of any kind that have previously been used on ordinary steel. Microscopic steel fibers transferred onto stainless steel can cause considerable damage to the surface and will void the warranty.

Do NOT - use abrasive cleaning brushes, pads or agents on highly polished finishes

Do NOT use harsh cleaners that contain powerful acidic or alkaline chemicals such as hydrochloric acid and sodium hydroxide that will damage the surface. Any water coming into contact with stainless steel, particularly cleaning solutions, should have zero chloride content as even minute amounts can cause damage. Using these cleaners will void any product warranty.

Do NOT - use chlorinated sanitizers, cleansers or bleach of any kind. Using these substances will void the warranty. Despite some cleaners displaying the text, 'Suitable for Toilets and Urinals' this is more likely in reference to ceramic /vitreous China products and use of these cleaners can damage stainless steel and will void the warranty.

Do NOT - use brick cleaning liquids that contain hydrochloric acid anywhere near stainless. If cement needs to be removed from stainless (before it sets), a mixture of hot water and 25% vinegar or 10% phosphoric acid can be effective. Once cleaned, the surface should then be neutralised with dilute ammonia or sodium bicarbonate then rinsed and dried.

AESW

Wall Mounted Sensor* (as provided with TW-WMS)

Installation and Cleaning Guide

Last revised Dec 2022

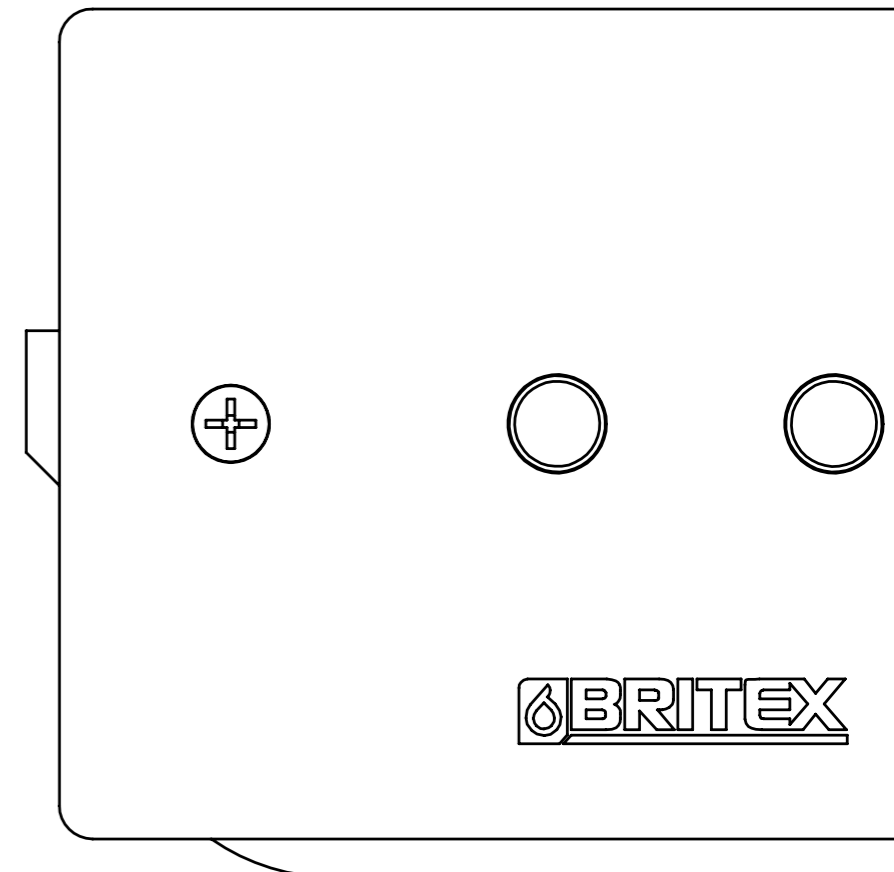

***Please note this item is pre-programmed to trip and run setting as per these notes. Wave on/ Wave off models are special order.**



MELBOURNE
Britex Place Mirra Crt
Bundoora VIC 3083
t (03) 9466 9000
e vic@britex.com.au

SYDNEY
16 Northumberland Drv
Taren Point NSW 2229
t (02) 9531 2100
e nsw@britex.com.au

PERTH
Unit 1/8 Principal Link
Malaga WA 6090
t (08) 9249 5464
e wa@britex.com.au

BRISBANE
19 Manilla St
East Brisbane QLD 4169
t (07) 3363 2400
e qld@britex.com.au

ADELAIDE
The Britex Group
SA State Office
t 1300 764 744
e sa@britex.com.au

About

Please note this item is pre programmed to trip and run setting as per these notes. Wave on/ Wave off models are special order.

A wall mounted, sensor operated trip and run hands free tap or wave on/wave off that is installed onto sinks and basins. Available with spout (TW-WMSXXX) or as is (AESW).

The Britex Sensor flow electronic tap is a wall mounted, sensor operated hands free tap that is installed onto sinks & basins. It operates by sensing an object, usually a hand, passing within around 7cm of the front of the sensor unit. It uses a beam of invisible infra red light which, if reflected from an object back to the sensor, will operate the unit.

The wall mounted plastic sensor kit consists of a sensor unit similar in appearance to a normal power point (115W x 75H x25D), a solenoid valve and a plug pack. The stainless steel sensor has the electronics mounted to stainless steel plate most installation problems are caused through damaging the unit at installation time or the selection of an inappropriate installation location, so select the location carefully and take care with the installation.

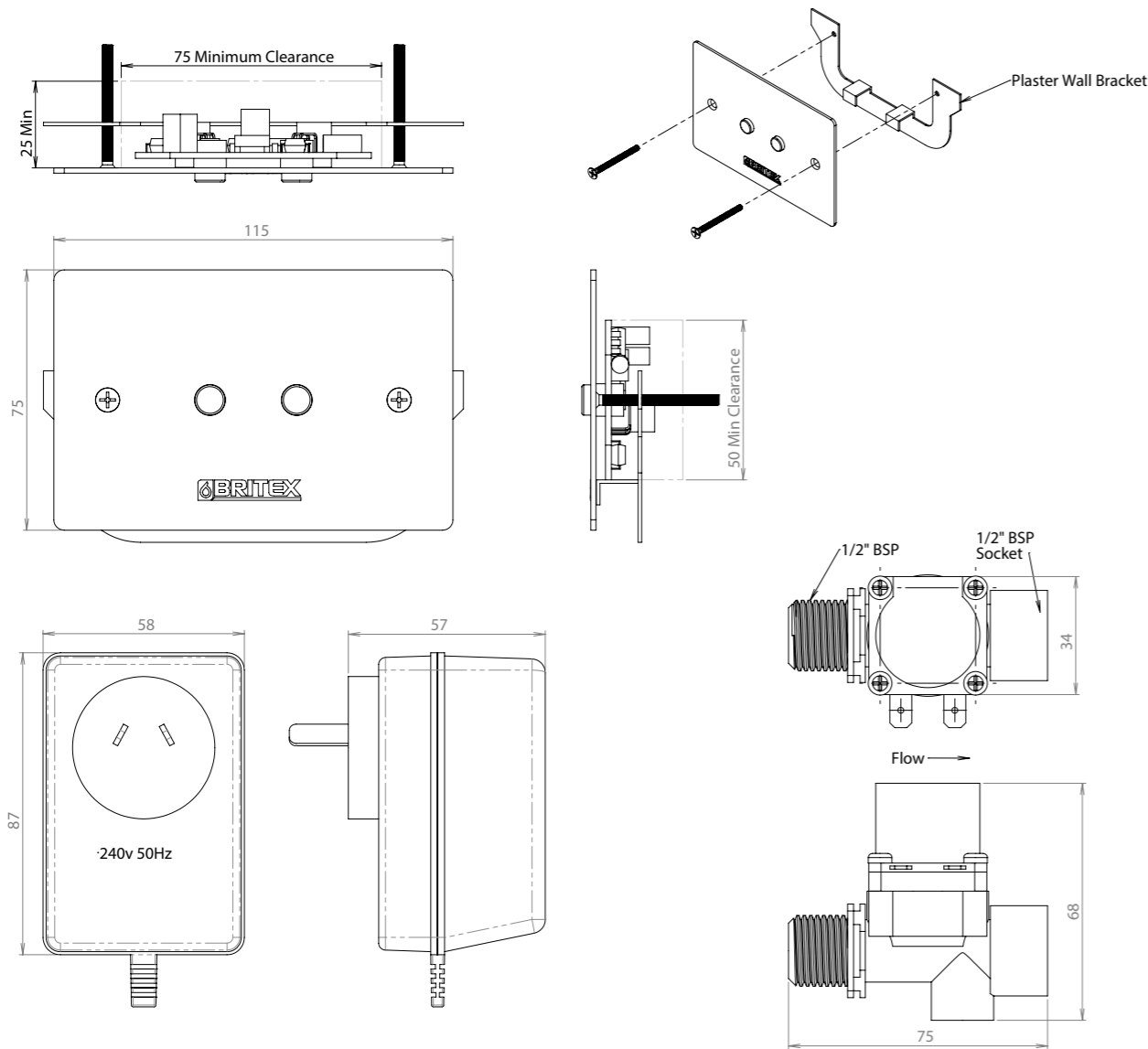
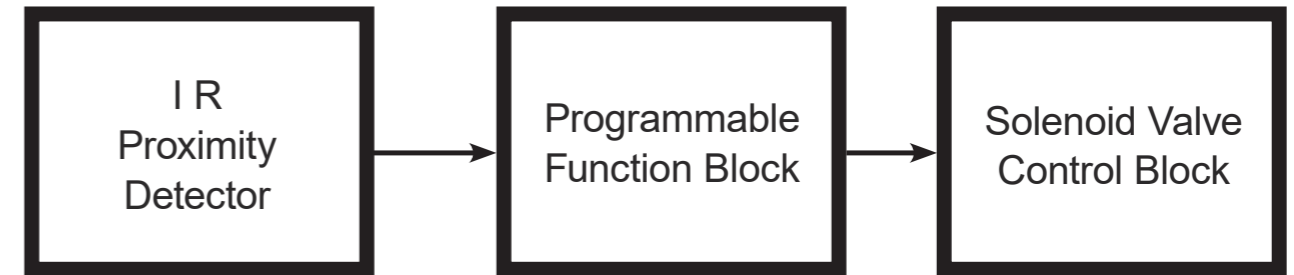

Fig 1: AESW Product Diagram

The unit can be conveniently viewed as shown here:



The function block is programmed to operate as a hands in front, trip & run (or a special order: wave on, wave off type) hands free tap. The unit has on the printed circuit assemble 6 miniature switches. Setting these switches determines the type of operation the tap takes on.

Functions of the switches

ATTENTION: THIS UNIT IS PRESET TO MEDIUM LOW SENSITIVITY TO RUN FOR 12 SECONDS. TO MAKE SETTING CHANGES PLEASE READ THROUGH THE FOLLOWING INSTRUCTIONS

Switch 1 & 2. These switches directly effect the power of the IR Led & therefore the sensing range of the unit.

Sw1	Sw2	Sensing Range
Off	Off	Low
On*	Off*	Medium Low*
Off	On	Medium High
On	On	High

* Setting Pre-selected

Switch 3. This switch selects the type of operation the unit takes on when configured as a wall mounted sensor tap i.e. Sw6 is set to off. Sw3 Off means the unit will operate as a Wave On, Wave Off unit, Sw On means the unit will operate as a Trip & Run unit. Please note that this only holds true if Sw6 is set to off.

Switches 4 & 5. These switches select one of four pre-set dead man timeout periods for the units, depending if it is operating as a Trip & Run or Wave On, Wave Off unit, that is, how long the trap will continue to run if held in the operated state, e.g. not waved off & left running.

These times are:

Sw3	Sw4	Sw5	Sw6 Wave On/Off	Trip & Run
Off	Off	Off	30 Sec	N/A
Off	Off	On	45 Sec	N/A
Off	On	Off	60 Sec	N/A
Off	On	On	75 Sec	N/A
On	Off	Off	OFF	6 Sec
On	Off	On	OFF	9 Sec
On*	On*	Off*	OFF*	12 Sec*
On	On	On	OFF	15 Sec

* Setting Pre-selected

Switch 6. Closing this switch causes the unit to operate as a hands in front type unit. Sw3, together with Sw4 & Sw5 then serve only to select the dead man time out period of the tap as detailed above eg. all 3 switches closed give a time of 15 secs, all open 30 secs, etc. Once Sw6 is closed, Sw3 does not change the operation of the tap.

Pipe Flush Option:

Units may be optionally programmed to provide a pipe flush option. This allows a tap to run for an extended pre-programmed period, up to 255 seconds to flush pipes etc. If available this function is called up by waving a hand past the units 4 times at 1 second intervals, within a 5 second period.

Flexibility: This is a much more flexible & capable design able to cater within reason with requests for special operating requirements & features.

Electrical Specifications:

Supply voltage 24VAC Standby power consumption, solenoid valve not operated: 150mWatts
Power Consumption: Depends on the solenoid valve connected to the unit up to 16watts
Solenoid valve: 24VAC up to 16watts