

**SUNWARD**

*Great ideal leads to great future*

# SWE 25UF

SWE 25UF MINI-SIZED EXCAVATOR



Distributed by;  
BMES - Brisbane Mini Excavator Sales Pty Ltd  
28 Old Pacific Highway, Yatala QLD 4207  
Tel: 07-3807-4333  
[www.bmesales.com.au](http://www.bmesales.com.au)



**Engine netpower:14.6kW**  
**Machine weight:2650kg**





## Outstanding performance

Powered by T4F and Stage 5 Yanmar engine and equipped with excellent hydraulic system and elements; coordinated and smooth compound movement of boom, bucket rod, bucket and slewing, which deeply impressed the users among products of the same tonnage.

### Electro-hydraulic proportional lever controls the flow (optional)



### Yanmar engine

With low noise and vibration, it is popular among compact equipment and it is easy to maintain the main components.



### Easy to transport



## A mini excavator with outstanding dynamics and performance

Configuration	Regular	Optional
Cab	●	
Open cab		●
Electro-hydraulic lever		●
Crusher pipeline	●	
Implement pipeline	●	●
Quick-changing lock pipeline		●





# Comfort cab

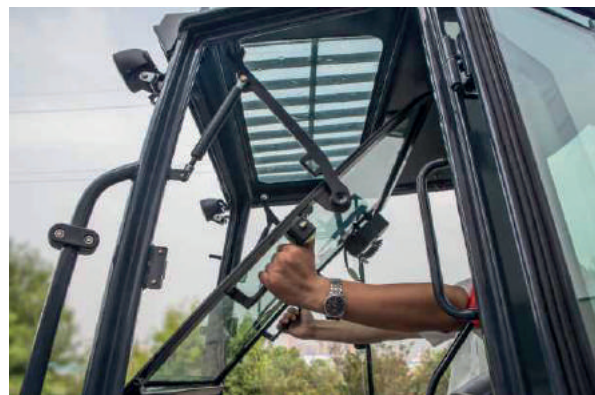

## Comfort operation environment

Wider space and wide view enabled by enlarged front windscreen and sunroof; in addition, the high-quality floating shock absorber seat, imitation leather interior on the top, radio, cup holder and reading light ensure a comfortable driving experience;

## Safe driving space

Frame supported cab with Fops/Tops safety certificate; regular top protection rail ensures safe driving; hidden seat belt, safety hammer, pilot lock rod, slewing parking brake, traveling parking brake and start-up mechanism of engine at neutral gear;



## Simple and easy switch control



## Clear monitoring instrument that is easy to operate

### List of display items

- Coolant temperature
- Fuel level
- Working hours
- Time
- Traveling mode
- Operation light
- Various warning lights of engine
- Overheat warning
- Oil pressure warning
- Charging indication
- Working light indication





## Easy service

The door and engine hood can be open completely for daily inspection and change of filter. The left lower service hole makes easier maintenance of multi-way valve without removing covering parts.

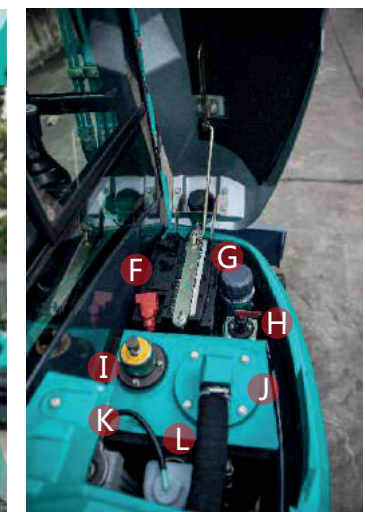
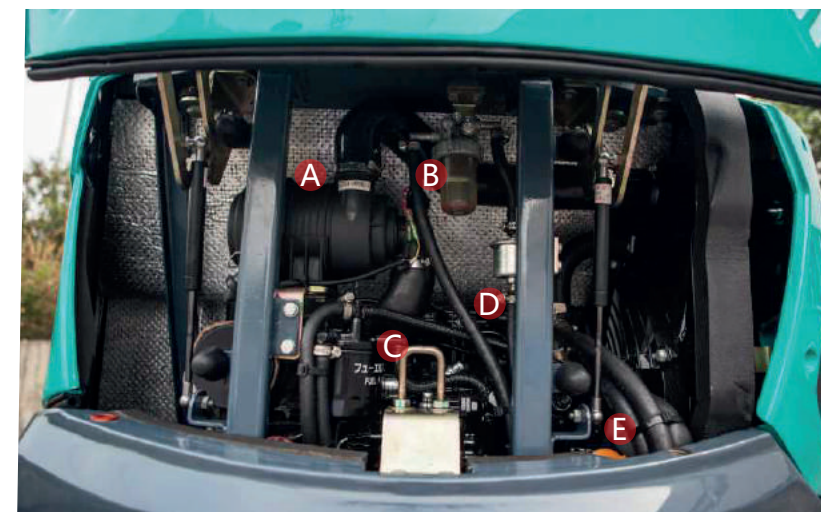
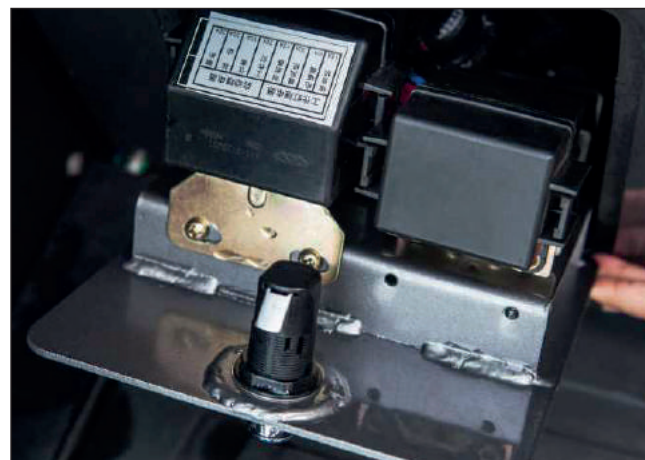

- |                              |                                    |                           |                            |
|------------------------------|------------------------------------|---------------------------|----------------------------|
| <b>A</b> Air filter          | <b>D</b> Electric oil suction pump | <b>G</b> Fuel filler      | <b>J</b> Return oil filter |
| <b>B</b> Oil-water separator | <b>E</b> Oil filler                | <b>H</b> Fuel filler      | <b>K</b> Coolant filler    |
| <b>C</b> Fuel filter         | <b>F</b> Battery                   | <b>I</b> Hydraulic filler | <b>L</b> Expansion tank    |



**LED working light**



**Sleeve of pipe wire**



**LED warning light**



**Crusher pipeline,  
assistant pipeline (optional)**

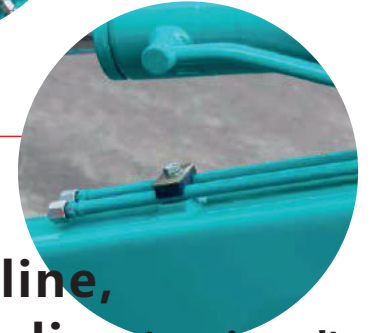

**Quick-changing  
lock pipeline (optional)**

**Securing bracket  
for transport**

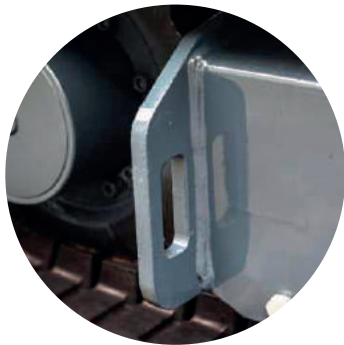

**Cast aluminium pedal**

**Collected grease filling**



**Cylinder protection panel**



**Cast deflection device**

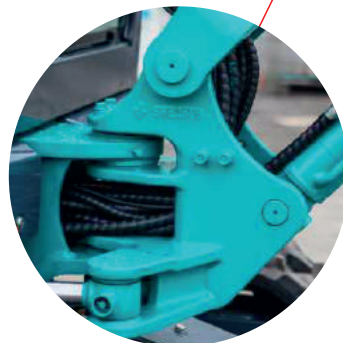

# Equipment

The regular and optional equipment varies from country to country. For more information, please contact with us.

Engine		Cab	
Oil filter	●	AM/FM radio	●
Fuel filter	●	Cup holder	●
Oil-water separator	●	Floating shock absorber seat	●
Air filter	●	Warm air blower	●
Radiator	●	Engine neutral start system	●
Alternator	●	Retractable safety belt	●
Expansion tank	●	FOPS/TOPS cab	●
Electronic fuel pump	●	FOPS/TOPS open cab	○
Silencer	●	Windscreen washer and wiper	●
Hydraulic system		Left/right rearview mirror	●
Hydraulic pilot control rod	●	Cigar lighter	●
Slewing parking brake system	●	Safety device of front windscreen	○
Traveling parking brake system	●	Front working devices	
Dual-speed traveling system	●	300 mm bucket	○
Auto traveling gear shifting system	●	485mm bucket	○
Electro-hydraulic proportional lever	○	580 mm bucket	●
Light		1000 mm bucket	○
Boom light	●	Crusher pipeline	●
Superstructure light	●	Implement pipeline	○
Front cab light	●	Quick-changing lock pipeline	○
Warning light	●	Components of understructure	
		300mm rubber track	●
		300mm steel track	○

● Regular equipment    ○ Optional equipment

SWE25UF Technical Parameters				
Type of cab	Closed/open			
Bucket capacity, std.	m <sup>3</sup>	0.08		
Bucket width	mm	580		
Machine weight	kg	2650/2550		
Dimensions	Overall length	mm	4140	
	Overall height	mm	2455	
	Overall width	mm	1500	
	Ground clearance	mm	310	
Engine	Brand	Yanmar		
	Model	3TNV80F-SPSU		
	Displacement	L	1.267	
	Output	kW/rpm	14/2400	
Working ranges	Max cutting height	mm	4355	
	Max loading height	mm	3010	
	Max digging depth	mm	2840	
	Max vertical wall digging depth	mm	2580	
	Max digging reach	mm	4775	
	Boom swing angle (left/right)	°	65/50	
	Front swing radius	mm	1980	
	Tail swing radius	mm	765	
	Max digging force (Arm)	kN	12.04	
	Max digging force (Bucket)	kN	24	
Track	Type	Rubber crawler		
	Rubber shoe Width	mm	300	
Undercarrige	Track Length	mm	1990	
	Length to center of Rollers	mm	1560	
	Lenhth to center of track	mm	1200	
	Travelling spaeed(High/Low)	km/h	4.1/2.3	
	Gradeability	deg	30	
Swing speed	rpm	8.8		
Ground pressure	kpa	25.1		
Dozer size	Width	mm	1500	
	Height	mm	325	
	Lifting capacity (Height/Depth)	mm	330/320	
Hydraulic pumps	Type	2 variable plunger pump, 1 Gear pump		
	Flow rate	L/min	2*28.8+19.2+6.5	
	Hydraulic pressure	Mpa	2*21.5+18	
Swing motor	Plunger motor			
Travel motor	2-speed plunger motor			
Fuel tank capacity	L	26		
Hydraulic oil tank capacity	L	24		

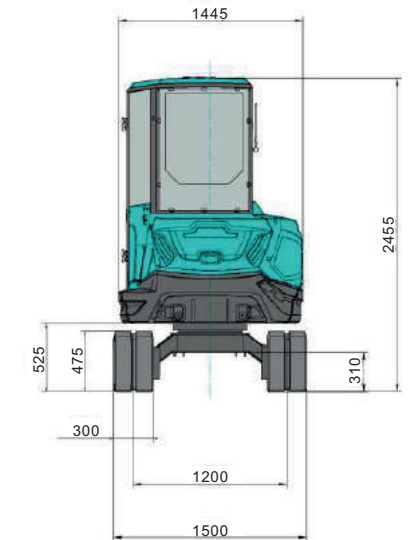
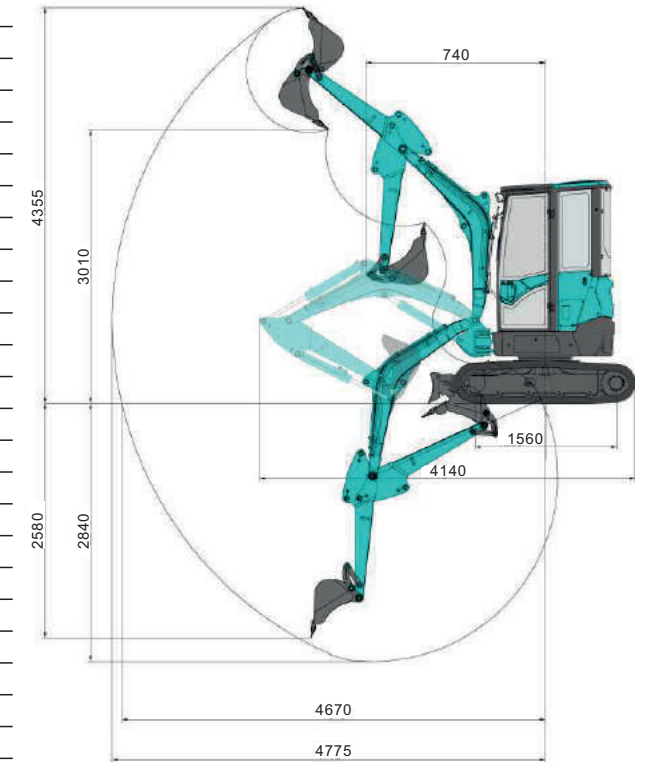

## Load Capacity:

Lift Point Height	Lift Point Radius(MAX)		Lift Point Radius(3.0m)		Lift Point Radius(2.0m)	
	Over-front(kg)	Over-side(kg)	Over-front(kg)	Over-side(kg)	Over-front(kg)	Over-side(kg)
3.0m	469.00*	404.3	469.00*	404.30	-	-
1.5m	540.80*	288.8	612.60*	420.80	-	-
0m	612.60*	176.4	813.60*	358.90	1292.20*	598.20
-1.0m	679.60*	363.1	679.60*	375.4	1005.00*	573.50



Notes :

- 1、 Load with \* is limited by hydraulic capacity and based on ISO 10567. Rated loads do not exceed 87% of hydraulic capacity.
- 2、 Load without \* is limited by tipping load and based on ISO 10567. Rated loads do not exceed 75% of tipping capacity.
- 3、 The excavator bucket, hook, sling and other lifting accessories are not included in this table.