



GR1003

MOTOR GRADER



www.xcmg.net.au

GR1003

PERFORMANCE, RELIABILITY VALUE

CUMMINS ENGINE

The GR1003 is fitted with a Cummins QSB3.9 4-cylinders engine and is equipped with electrically control high-pressure common rail, turbocharger



GROUND LEVEL ACCESS

Daily checks are efficient thanks to easily accessible service and maintenance components, including re-fuelling, fluid checks and air filters.

EASY SERVICE ACCESS

All daily maintenance points are easily reached and serviced from the ground, ensuring simple day-to-day checks for the operator.

Designed to perform...



MOTOR GRADER

SAFE AND RELIABLE

Full hydraulic braking system, load sensing steering, and optimised control structure reducing operating force by up to 30%.

DUAL CIRCUIT ISOLATORS

Dual circuit isolators provide more flexibility for operators and/or repair personnel when performing service and maintenance operations - improving the overall safety of the machine.

DUAL EMERGENCY STOPS

E-stops are located inside the cab as well as outside to the rear of the machine to ensure easy access to shut down the machine in case of an emergency.

STEERING WHEEL

The ergonomically-designed steering wheel reduces operator fatigue and is full adjustable to suit all operators.

EFFICIENT OPERATION

The GR1003 offers a remarkably comfortable, flexible and ergonomic control system, engineered for smooth and efficient operation.

MANOEUVRABILITY

The single oil cylinder, large steering angle, and front axle are all XCMG patented technologies, which combined with an articulated frame and small turning radius, ensure greater manoeuvr.

REVERSING CAMERA STANDARD

A high resolution 10" LCD Screen gives the operator a commanding view of the rear of the machine while reversing.

BLADE DESIGN

The optimised blade shape works quickly and efficiently, whilst creating optimal load distribution and minimal material accumulation within the rotary disc area.



...built to last.

GR1003



Ergonomic operator control system

Reverse camera and rear work lights



Air conditioned cabin with temperature control



MOTOR GRADER

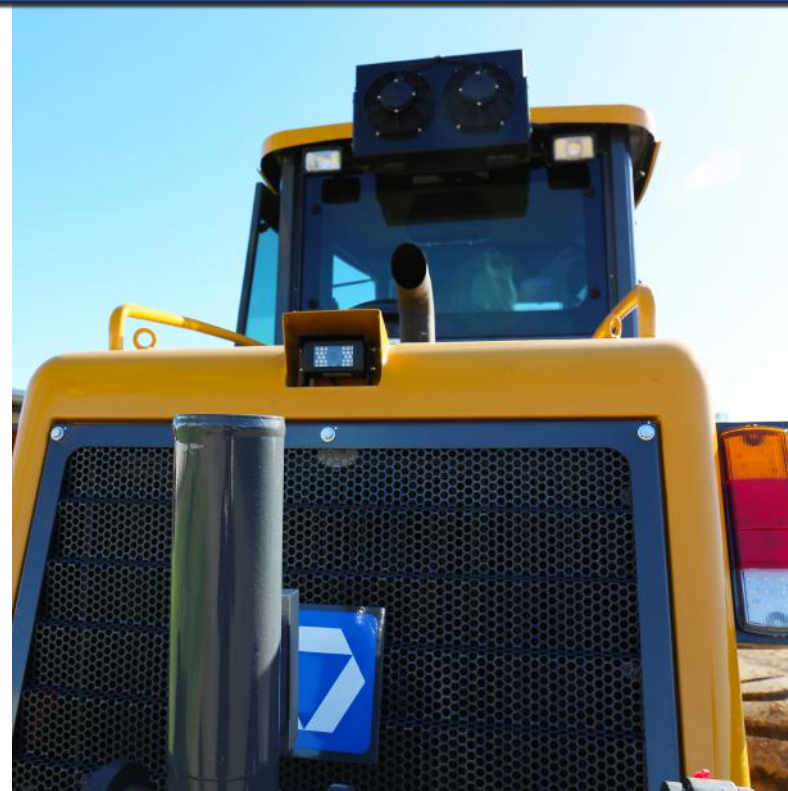

GR1003 SPECIFICATIONS

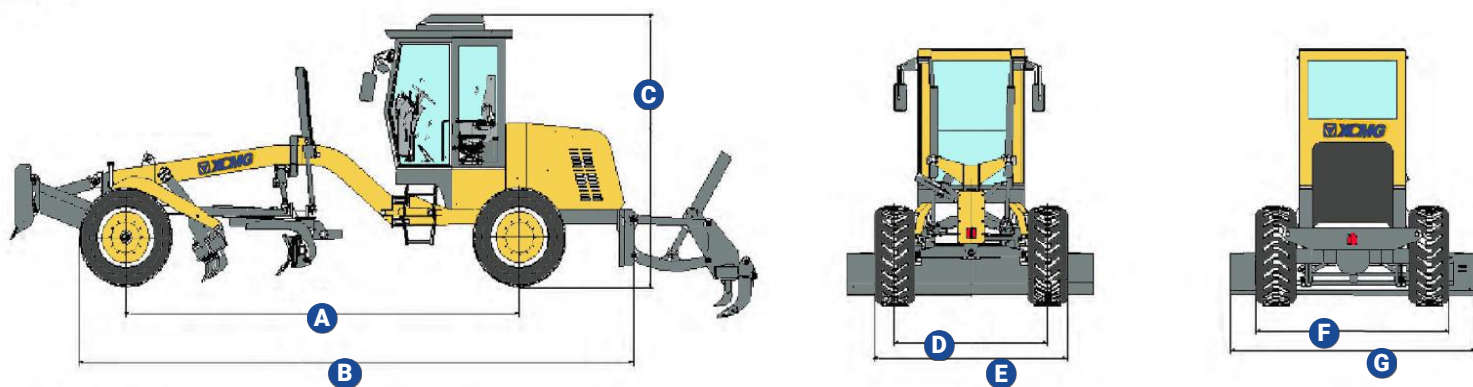

GR1003	A	B	C	D	E	F	G
mm	5135	7130	3150	1900	2375	2375	3048

KEY PERFORMANCE SPECIFICATIONS

Key Specs	Engine Model:	QSB 3.9
	Rated Power/Speed:	81/2200 kW/rpm
	Overall Dimension:	7130 x 2375 x 3150
	Total Weight:	7500 kg
	Tyre Specification:	16/70 - 24/13 - 24
	Ground Clearance:	550 mm
	Tread:	1900 mm
	Front and Rear Axles:	5135 mm
	Coolant:	50 L
	Fuel Tank:	260 L
	Engine:	18 L
	Transmission:	26 L
	Drive Axle:	28 L
	Hydraulic Oil:	89 L
Performance	Forward Speed (6 Speed):	5, 8, 11, 17, 24, 38 km/h
	Reverse Speed (3 Speed):	5, 11, 24 km/h
	Tractive Effort (f=0.75):	≥ 39 kN
	Max Gradeability:	≥ 25 %
	Pressure of Tyres:	300 kPa
	Working System Pressure:	16 MPa
	Transmission Pressure:	1.3 - 1.8 Mpa
Blade	Max Lifting Height:	310 mm
	Max Shoveling Depth:	350 mm
	Max Lateral Inclination Angle:	45 °
	Cutting Angle:	28 - 70 °
	Slewing Angle:	120 °
	Length x Chord height:	3048 x 450 mm
Additional Specs	Max Steering Angle - Front Wheels:	±49 °
	Max Inclination - Front Wheels:	±17 °
	Max Swing Angle - Front Axle:	±15 °
	Max Swing Angle - Balance Box:	±16 °
	Max Steering Angle - Frame:	±27 °
	Min Turning Radius:	6 m

Note: specifications listed above are correct at March 2022 and are subject to change any time. For additional information visit www.xcmg.net.au.

ABOUT US

INDUSTRY EXPERTISE

XCMG is one of Australia's fastest growing construction, mining and agriculture equipment suppliers.

Offering premium quality excavators, wheel loaders, compaction rollers, graders, elevated work platforms and more, XCMG has the products and the support to keep you working on any job site.

MACHINERY SALES

XCMG know construction, mining and agri machinery. Count on our dedicated and knowledgeable team of product experts to take the time to understand and satisfy your machinery needs by recommending the right solution for the job.

AFTERMARKET SUPPORT

We're here to help keep you and your machine working. With an exceptional over-the-counter fill rate on spare parts, you're assured that when you buy an XCMG machine, you'll be looked after throughout your machine's entire lifetime, from start to finish.

Every service job is as important to us as it is to you, and with a dedicated team of machinery technicians, we have ample resources to look after any of your machine repairs or servicing requirements quickly and efficiently.

RENTALS & HIRE

If you need a high-performance machine with reliability you can trust, and the flexibility of hiring, we have you covered.

Our fleet is diverse, with machines to suit almost any job. Furthermore, because our rental fleet is maintained by factory-trained technicians, you can be confident that you'll not only be getting the best machines on the market, but that it's going to work as hard as you do, day-in day-out.

ABOUT

The World's 3rd largest manufacturer of construction and mining equipment.

Founded in 1943 - equipped with more than 8 decades of experience in the industry.

Manufacturing facilities located around the world: USA, Germany, China, Brazil and India.

Extensive supply chain and dealer network throughout Australia offering premium aftersales service and parts support.

Deep relationships with corporate giants Rio Tinto, BHP and MMG in Australia.

MINI / LARGE EXCAVATORS

1 to 100+ Tonne

WHEEL LOADERS

5 to 100 Tonne

COMPACTION ROLLERS

1.5 to 30 Tonne Smooth & Padfoot

GRADERS

7.5 to 70 Tonne

ACCESS EQUIPMENT

Lift Heights from 5 to 21 Metres

MINING TRUCKS

20 to 100 Tonne

FIND OUT MORE & LOCATE YOUR NEAREST DEALER:

www.xcmg.net.au

“XCMG: FOR YOUR SUCCESS”



YOUR LOCAL XCMG DEALER:



www.xcmg.net.au