



RINSING



**NEW**



FILLING



SEAMING



# **CAN** **BLOCK 6/6/1-LE**

*Fully automatic electronic canning machine  
Rinsing, isobaric filling and seaming  
Beer, Cider, Soft Drinks, Wine, etc.*

***Sturdy, Compact, Electronic, Reliable***

***Output:  
up to 1.500 cans hour***

**FRAMAX**

# CAN BLOCK 6/6/1-LE

*Fully automatic electronic canning machine. Rinsing, isobaric Beer, Cider, Soft Drinks, Wine, etc.*

*The CANBLOCK is a fully automatic electronic canning machine including a 6 position rinser, 6 valve electro-pneumatic counterpressure filler and a single-head seamer with automatic lid dispensing system.*

*Each phase can be fully programmed*



## Details

- Sturdy frame, resistant to bending and vibrations
- Rinsing by tilting the cans 180°
- Automatic filling cycle (electro-pneumatic)
- Electronic control of the different phases, with settings adjustable from the operator's panel
- Multiple CO2 flushing system to minimize oxygen pickup
- Buffer tank included to provide constant product supply
- Easy and fast maintenance operations
- CIP predisposition
- All parts in contact with the product made in stainless steel AISI 304 or AISI 316.

## Rinser



## Filler



*filling and seaming.*

**Output:  
up to 1.500 cans/hour**

# SMALL CANNING



**BEER, WINE, CIDER,  
SOFT DRINKS**



*Touch screen  
control panel*



*Multiple recipe  
Management: Each phase  
can be fully programmed  
by the operator to suit  
the product to be filled  
(Vacuum, CO2 injection,  
filling, snifting).*

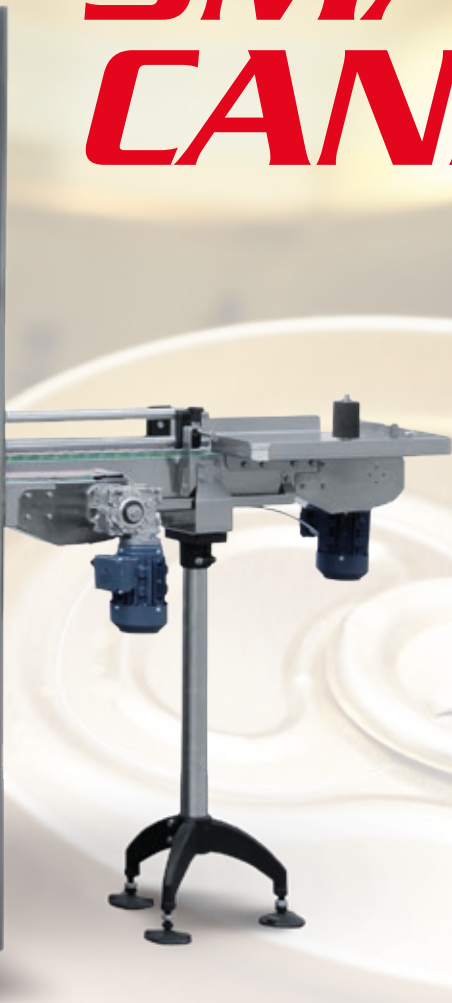
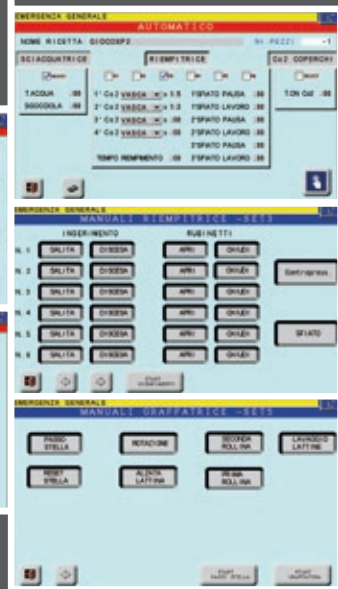

**Seamer**

**CIP Mode**

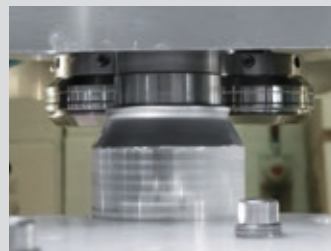
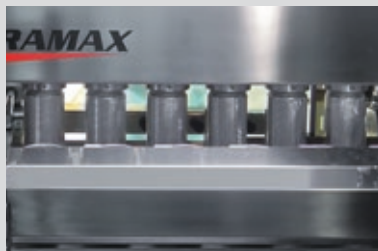

# CAN BLOCK 6/6/1-LE

Sturdy, Compact, Electronic, Reliable

## Technical data:

- Can Height range 115-170mm (or on request)
- Inlet product: DN 40
- Work height from floor: 1.050mm +/-50mm
- Display: colour touch screen
- Approx. overall dimensions: mm 2150\*1050\*2350h
- Machine manufactured according to CE safety regulations.

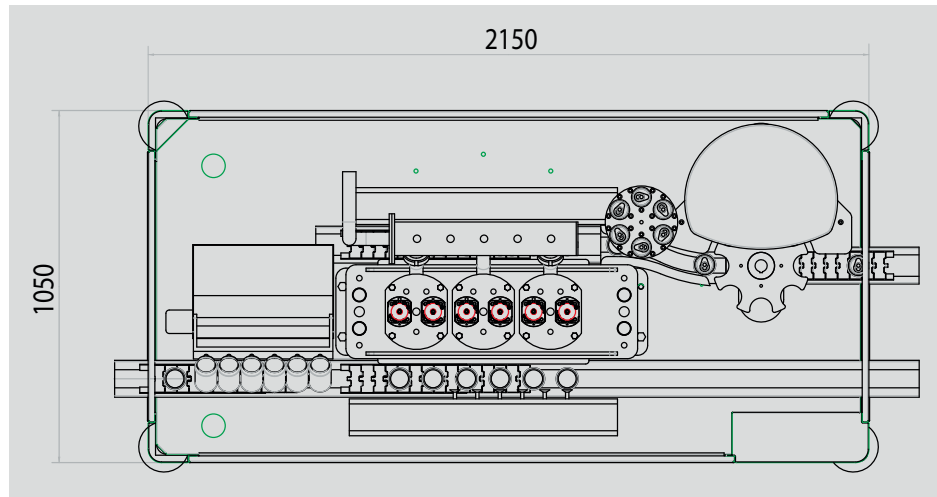

## Optional:

- Labeller at inlet
- Hot foil printer for labels
- Shower at the outlet
- Collection table
- Wheels

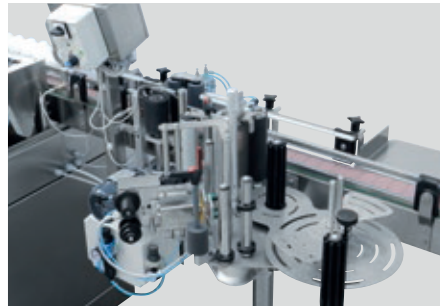

Labeller

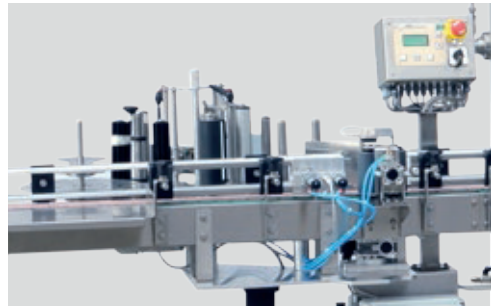

Supplied by:

**FB\*PROPAK**

**FOR MORE INFO:**

### In Australia:

Technical Sales Team  
p: + 61 3 9487-1150  
info@fbpropak.com  
www.fbpropak.com

### In New Zealand:

p: + 64 3 577 8778  
info@fbpropak.com