



Pratt Burnerd International
Guide to Workholding

Support & Service



Buy Spare Parts

You can buy Colchester, Harrison and Clausing spare parts from us, our experts are there to help you identify the correct replacement part and ensure prompt delivery every time.



Reliable Servicing

Our factory trained engineering team are always available to support your machine tool, either through our dedicated help-desk or out in the field.



Machine Tool Finance

Colchester Machine Tool Solutions offer finance options to support your machine tool purchase.



Valuable Training

Whether it's when your new machine arrives, or more intensive courses to ensure that you make the most of your machine tool, our applications specialists are there to support you.



Delivery & Installation

Our service teams are on-hand to effectively deliver, install and commission your machine tool exactly to your satisfaction.



Preventative Maintenance

We work closely with you on a range of preventative maintenance contracts ensuring your assets are utilised fully, whether for one machine or a workshop of our machine tools.

FOR FURTHER INFORMATION OR TO REQUEST A DEMONSTRATION
PLEASE CONTACT OUR SALES TEAM 02 9674 4738 | sales@colchestermachines.au | colchestermachines.au

27 Foundry Road | Seven Hills | NSW 2147



Certificate No. QEC20541



The home of Pratt Burnerd International and Dickson products

Pratt Burnerd International have a worldwide reputation for the manufacture of manual and power chucking systems for a wide range of industrial and training applications. This is also the home of the original and world renowned Dickson Toolpost.

Contents

• Super Precision Chucks	4
• Standard Accuracy Chucks	6
• Griptru Scroll Chucks 3 & 6 Jaw	8
• Setrite Scroll Chucks	10
• Lever Operated Scroll Chucks	12
• Super Thin Round Chucks	13
• Metric 4 Jaw Independent Chucks	14
• Large Scroll Chucks - Medium & Heavy duty	16
• Large 4 Jaw Independent Chucks - Medium & Heavy Duty	17
• Gripfast Power Chucks	18
• Self-contained Pneumatic Power Chucks	20
• Gripsafe - Gripmeter	21
• Front Hand Wheel Collet Chucks 5C and 16C	22
• Quick Change 5C Collet Chuck	24
• Air Power Front Mount Collet Chucks	24
• Spindle Conversion Adaptors	25
• Chuck Lubricant	25
• Dickson Quick Change Toolposts and Toolholders	26
• Standard Spindle Nose Data	28



Pratt Burnerd International 3 Jaw Super Precision Scroll Chucks

Widely used for many years on the world's most popular manual lathes, the Pratt Burnerd Super Precision chuck is ideal for all high speed applications. The body is made from high strength nodular iron with hardened and ground jaw strips for extended working life. Through the body mounting holes allow for easy fitting and a wide range of fully machined adaptor plates to suit most common spindle noses are readily available.

Exceeds ISO 3089: 1991 (E) Class I

- 30µm T.I.R. up to 250mm size, 315mm and above 50µm T.I.R. using nominated pinion
- Repeatability 25µm on all sizes
- Sizes 80mm to 400mm
- Three hardened pinions
- Complete with one set of each hard inside and hard outside jaws
- American style two piece jaws available as an option
- Twelve month warranty

Mounting plates are precision machined to suit the spindle nose of your machine. If ordering plate separately please specify the model number of your chuck.

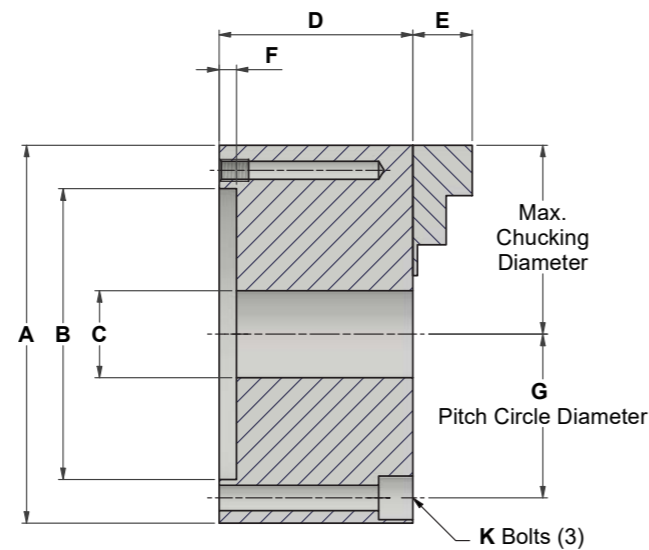

Chuck Size	Model Number	Approx. Weight (kilos)	Maximum rpm
80mm	9210-00805	1.7	5000
100mm	9210-01005	2.9	5000
125mm	9210-01305	4.7	5000
160mm	9210-01705	8.6	4900
200mm	9210-02005	15.6	4200
250mm	9210-02505	27	3300
315mm	9210-03205	45	2700
400mm	9210-04005	83	2000

Dimensional Data for 3 Jaw Super Precision Scroll Chucks

Chuck Size								Gripping Capacity	
(A)	B(H7)	C	D	E	F	G	K	Min	Max
80	63.5	19	45	13	3	71.3	M5	1	76
100	76.2	25.4	51.3	17	3	89	M6	1	98
125	95	35	57	19	4	108	M8	1.5	124
160	125	45.9	63.9	23	4	140	M10	1.5	160
200	160	54.8	74.2	29	4	176	M10	2	200
250	200	75.9	82.2	33	5	224	M12	3	250
315	260	105	91	40	5	286	M12	6	304
400	330	136	100.7	50	5	362	M16	10	406

Type D Camlock Mounting Plates

Spindle	100mm	125mm	160mm	200mm	250mm	315mm	400mm
D-3	8271-10222	8271-13222	8271-17222	8271-20222			
D-4		8271-13223	8271-17223	8271-20223	8271-25223		
D-5			8271-17224	8271-20224	8271-25224		
D-6			8271-17225	8271-20225	8271-25225	8271-32225	8271-40225
D-8			8271-17226	8271-20226	8271-25226	8271-32226	8271-40226
D-11				8271-20227	8271-25227	8271-32227	8271-40227

Other adapter plates are available upon request. Specify chuck number and spindle nose specifications. For spindle nose specifications, see page 28.

We can supply soft blank jaws for all above models, please ask for details.

Pratt Burnerd International 3 Jaw Standard Accuracy Scroll Chucks

Introduced as an **economic alternative** to the Super Precision chuck, these slightly slower rated chucks are an ideal replacement for fitting to an older lathe where high speed and super accuracy are not such an issue. They also have a body made from high strength nodular iron with hardened and ground jaw strips and convenient, through the body mounting holes. These chucks use the same wide range of ready to fit adaptor plates as Super Precision chucks.

ISO 3089: 1991 (E) Class II

- 100µm T.I.R. up to 160mm, 150µm T.I.R. 200 to 250mm, 315mm and above 200µm T.I.R.
- Repeatability 25µm on all sizes
- Sizes 80mm to 500mm
- Three hardened pinions
- Complete with one set of each hard inside and hard outside jaws
- Twelve month warranty

Mounting plates are precision machined to suit the spindle nose of your machine. If ordering plate separately please specify the model number of your chuck. D Camlock type adaptor details can be found on page 4.

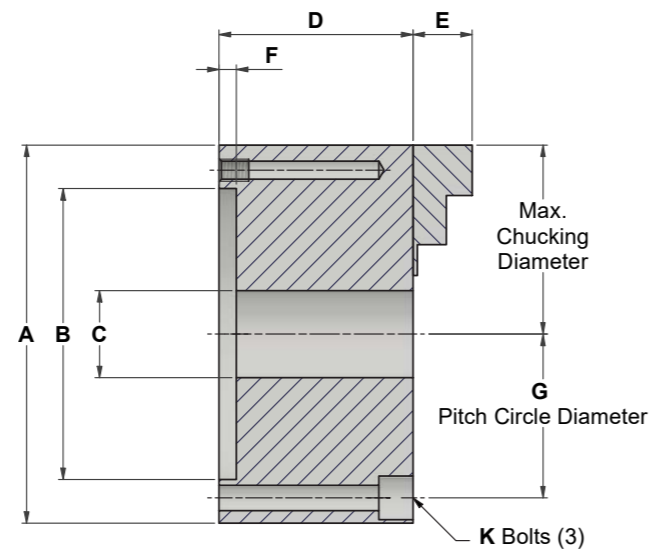

Dimensional Data for 3 Jaw Standard Accuracy Scroll Chucks

Chuck Size								Gripping Capacity	
(A)	B(H7)	C	D	E	F	G	K	Min	Max
80	63.5	19	45	13	3	71.3	M5	1	76
100	76.2	25.4	51.3	17	3	89	M6	1	98
125	95	35	57	19	4	108	M8	1.5	124
160	125	45.9	63.9	23	4	140	M10	1.5	160
200	160	54.8	74.2	29	4	176	M10	2	200
250	200	75.9	82.2	33	5	224	M12	3	250
315	260	105	91	40	5	286	M12	6	304
400	330	136	100.7	50	5	362	M16	10	406
500	420	190	120	54	8	458	M16	25	500

Other adapter plates are available upon request. Specify chuck number and spindle nose specifications.

For standard spindle dimensions, see page 28.

We can supply soft blank jaws for all above models, please ask for details.

Chuck Size	Model Number	Approx. Weight (kilos)	Maximum rpm
80mm	9580-00805	1.7	4000
100mm	9580-01005	2.9	3800
125mm	9580-01305	4.7	3700
160mm	9580-01705	8.6	3500
200mm	9580-02005	15.6	3200
250mm	9580-02505	27	3000
315mm	9580-03205	45	2300
400mm	9580-04005	83	2000
500mm	9580-05005		1100

Pratt Burnerd International 3 Jaw Griptru Scroll Chucks

Often used in grinding operations, these chucks allow the operator to re-align the front body of the chuck and therefore the workpiece in relation to the spindle nose, thus giving increased accuracy of within 0.005mm. The chuck will then grip subsequent workpieces of the same diameter within 0.013mm. Griptru chucks can be used as normal chucks, simply by leaving the front body in the central position.



These chucks require special adaptors, please contact the factory for details. **We supply soft blank jaws for all above models please ask for details.**

Exceeds ISO 3089: 1991 (E) Class I

- Micro adjustment feature allows chuck to be trued to within 0.005mm
- Repeatability 0.013mm on same size component
- Sizes 80mm to 315mm
- Three hardened pinions
- Complete with one set of each hard inside and hard outside jaws
- High strength nodular iron bodies
- Twelve month warranty

Chuck Size	Model Number	Approx. Weight (kilos)	Maximum RPM
80mm	9250-00805	2	5000
100mm	9250-01005	3.1	5000
125mm	9250-01305	5.4	5000
160mm	9250-01705	9.6	5000
200mm	9250-02005	16.8	4900
250mm	9250-02505	31.7	4200
315mm	9250-03205	47.4	3300

Dimensional Data for 3 jaw Griptru Scroll Chucks

Chuck Size								Gripping Capacity	
(A)	B(H7)	C	D	E	F	G	K	Min	Max
80	63.5	19	54	14	12	71.3	M5	1	76
100	76.2	25.4	56.6	17	12	88.9	M6	1	98
125	95	35	69	19	15	107.9	M8	1.5	124
160	125	45.9	78.6	23	20	139.9	M10	1.5	160
200	160	54.8	89.8	29	22	176	M10	2	200
250	200	75.9	101.3	33	25	224	M12	3	250
315	260	102.8	110	40	25	286	M12	6	304

Pratt Burnerd International 6 Jaw Griptru Scroll Chucks

Chucks with 6 jaws are used to reduce distortion in thin walled components, or to spread the gripping force more evenly, giving a better finish in grinding operations. These chucks allow the operator to re-align the front body of the chuck and therefore the workpiece in relation to the spindle nose, thus giving increased accuracy of within 0.005mm. The chuck will then grip subsequent workpieces of the same diameter within 0.013mm. Griptru chucks can be used as normal chucks, simply by leaving the front body in the central position.



These chucks require special adaptors, please contact the factory for details. **We supply soft blank jaws for all above models please ask for details.**

Exceeds ISO 3089: 1991 (E) Class I

- Micro adjustment feature allows chuck to be trued to within 0.005mm
- Repeatability 0.013mm on same size component
- Sizes 125mm to 315mm
- Three hardened pinions
- Complete with one set of each hard inside and hard outside jaws
- High strength nodular iron bodies
- Twelve month warranty

Chuck Size	Model Number	Approx. Weight (kilos)	Maximum RPM
125mm	9260-01305	6.2	5000
160mm	9260-01705	11	4900
200mm	9260-02005	18.9	4200
250mm	9260-02505	36.7	3300
315mm	9260-03205	53.4	2700

Dimensional Data for 6 jaw Griptru scroll Chucks

Chuck Size								Gripping Capacity	
(A)	B(H7)	C	D	E	F	G	K	Min	Max
125	95	35	69	19	15	107.9	M8	1.5	124
160	125	45.9	78.6	23	20	139.9	M10	1.5	160
200	160	54.8	89.8	29	22	176	M10	2	200
250	200	75.9	101.3	33	25	224	M12	3	250
315	260	102.8	110	40	25	286	M12	6	304

Setrite® Self Centring Scroll Chucks 3 Jaw and 6 Jaw Versions

- Precision manufactured for adapter mounting
- 12µm TIR repeatability on duplicate parts
- Steel body on sizes 160mm to 380mm
- Semi-steel body on the 125mm chucks
- 4 adjusting screws -125mm to 310mm
- 8 adjusting screws - 380mm
- Sizes 125mm to 380mm
- Nitride hardened scroll
- Hardened pinion
- Two-piece American standard tongue and groove jaws on chuck sizes 160mm to 380mm
- 125mm chucks equipped with one set of hard inside jaws and one set of hard outside jaws
- One pinion - up to 310mm
- 3 pinions - 380mm
- Durability - double the contact surface of the master jaw & body versus our competitor's chucks
- Twelve month warranty

Eccentric adjustment of chuck on mounting plate to obtain required TIR on the workpiece may result in unacceptable vibration at these speeds.

Reduce rpm's accordingly.

Jaws must be fully engaged in the chuck body.

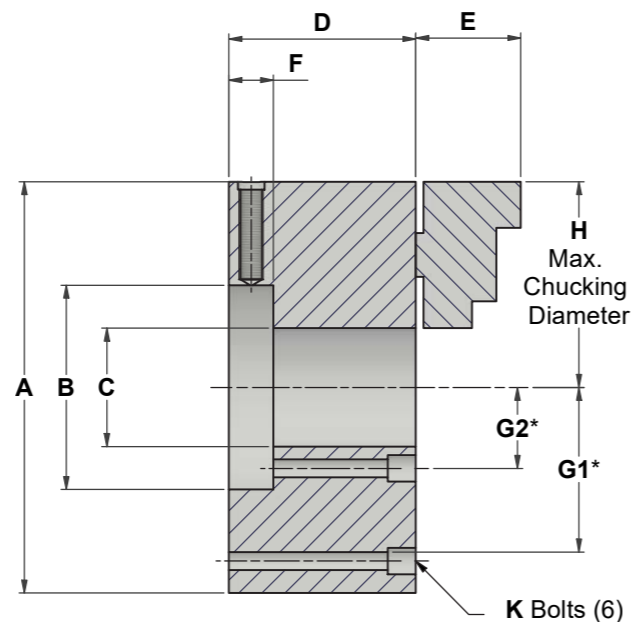

3 Jaw

Chuck Size	Model Number	Approx. Weight (kilos)	Maximum rpm
5"/125mm	9219-01351	6	5000
6"/160mm	9219-01360	12	4900
8"/210mm	9219-01370	21	4200
10"/250mm	9219-01380	32	3300
12"/310mm	9219-01390	51	2300
15"/380mm	9219-01400	66	2000

6 Jaw

Chuck Size	Model Number	Approx. Weight (kilos)	Maximum rpm
5"/125mm	9219-01356	7	2600
6"/160mm	9219-01365	12	2500
8"/210mm	9219-01375	22	2200
10"/250mm	9219-01385	35	1900
12"/310mm	9219-01395	53	1500
15"/380mm	9219-01405	93	1300

Dimensional Data Setrite® Adapter Mounting Self-Centring Chucks

Chuck Size										Gripping Capacity	
(A)	B*	C	D	E	F	G1	G1	H	K	Min	Max
125	60.32	33	72		16.7	112.8		127	1/4	2	100
160	79.37	46	73	41	17.4	135.7		185	1/4	5	127
210	120.65	57	82.5	44.5	19	190.5		235	3/8	5	165
250	161.92	76	92	54	20.6		111.1	279	7/16	5	203
310	200.81	103	101.6	58.7	20.6		133.3	355	1/2	19	254
380	299.24	116	130	79.4	28.6		171.4	432	5/8	38	330

PBI offers a full range of Mounting Plates type "D", "A", "L" and threaded plates for the Setrite® Chucks.

Mounting plates are precision machined to suit the spindle nose of your machine. For maximum accuracy of Setrite® mounting plates, mount plate on machine spindle nose, place a dial indicator on the chuck side face of the adapter close to the mounting holes, rotate the adapter and if the total indicator reading (TIR) exceeds 12µm take a light truing cut across the face of the mounting plate.

[For standard spindle dimensions, see page 28.](#)

Lever Operated Scroll Chucks 3 Jaw Light Duty Self-Centring Chucks

These lightweight, all steel chucks have been designed specifically for use on small precision machines such as watchmaker's lathes, glassworking lathes, light grinding machines, engraving machines and for other similar applications. Grip is limited, since the design is without gearing, but this facilitates holding fragile or easily-deformable components. Normally supplied with one set each of inside and outside jaws, but available also with soft blank jaws only.

Recess Mount Chucks and general dimensions

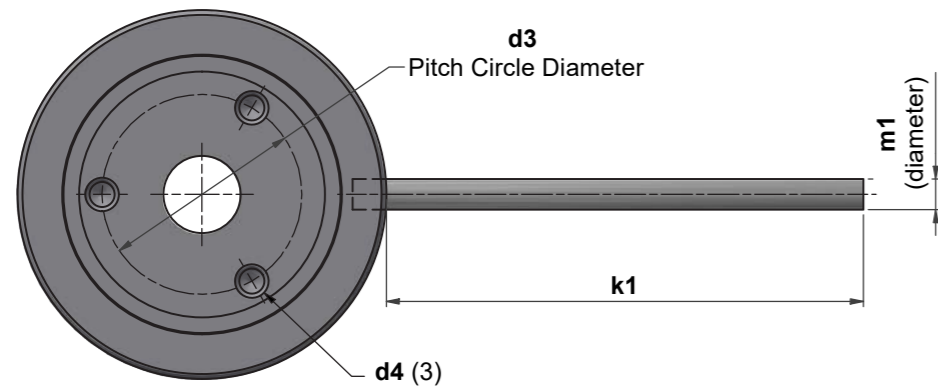
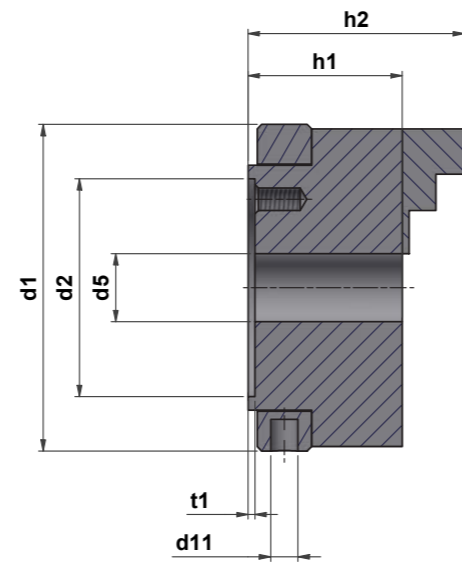

Chuck Size	70mm	110mm
Catalogue No With hard jaws With soft jaws	9460-00705 9460-00706	9460-01005 9460-01006
d1	72	112
d2	48.0 H7	75.0 H7
d3	39.0	62.0
d4	M6	M8
d5	15.0	26.0
d11	6.0	6.0
h1	32.0	38.0
h2	46.3	55.0
k1	100	100
m1 (diameter)	8.0	8.0
t1	1.5	2.0
w1	10.0	14.0
weght (kg)	0.9	2.4

Pratt Burnerd International Super Thin Round Chucks 9330 Series

The Ultimate Low Profile 3-Jaw Universal Chuck

- Three operating pinions positioned at a 45 degree angle for easier operation
- Four sizes available 160mm to 315mm diameter
- Easy installation with flange type mounting
- Accurate- 25µm repeatability on duplicate parts using the nominated pinion
- Ideal for drill presses, standard mills, vertical machining centres, angle plates, tombstones, and grinding machines
- American standard hard top and master jaws
- Twelve month warranty

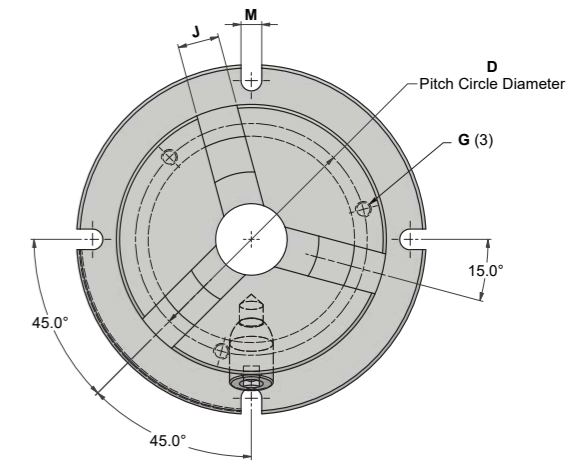
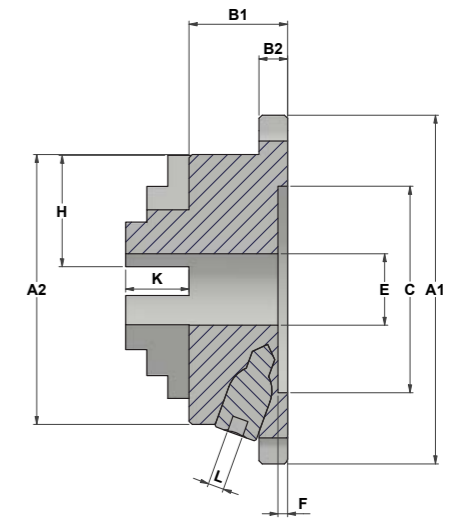

Model Number	Approx. Weight (kilos)	Maximum RPM	Gripping Capacity External		Gripping Capacity Internal	
			Min	Max	Min	Max
9330-01715	12	5000	7	70	48	140
9330-02115	19	4900	7.5	89	62	190
9330-02615	29	4200	9	105	72	241
9330-03115	47	3300	11	130	81	292

Dimensional Data for Super Thin Round Chucks

Size	A1	A2	B1	B2	C	D	E	F	G	H	K	L	M	
160	220	170	62	18	130	146	45	6	M10	69	26	40	10*	13
200	270	210	65	20	155	172	60	6	M10	85	28	43	11*	13
250	315	255	73	20	190	210	80	6	M12	98	32	51	12*	16
315	370	305	80	22	250	286	105	5	M12	123	41	59	14*	18

*square drive

Also available as a 4 jaw Super Thin Square chuck please ask for details

Pratt Burnerd International 4 Jaw Metric Independent Chucks

- Precision manufactured, recess mount or adaptor mounting
- S.G. iron body
- Sizes 160 to 400mm
- Hardened operating screws
- Solid reversible hard jaws
- Special jaw and jaw way design adding extra bearing surfaces, increases chuck life and rigidity
- Twelve month warranty

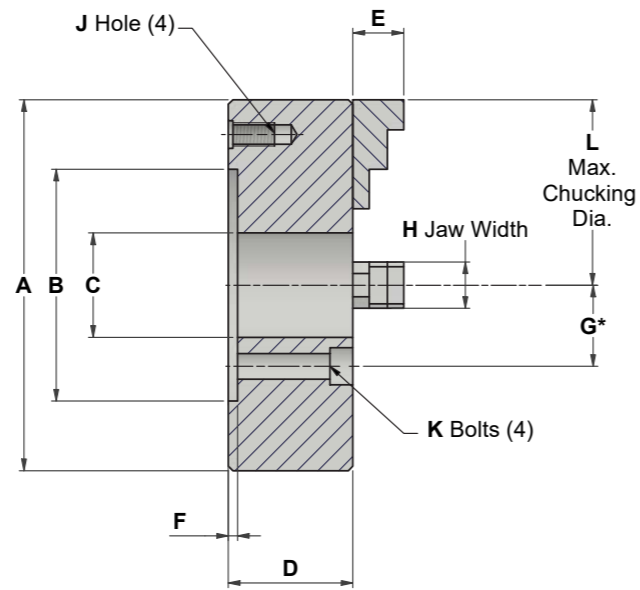

Chuck Size	Model Number	Approx. Weight (kilos)	Maximum rpm
160mm	9500-01701	5.6	3000
200mm	9500-02001	14	2300
250mm	9500-02501	19.5	1700
315mm	9500-03201	32.2	1500
350mm	9500-03501	46	1300
400mm	9500-04101	60	1300

Dimensional Data for Adapter Mounting Chucks

Chuck Size											Gripping Capacity	
(A)	B	C	D	E	F	G	H	J	K	L	Min	Max
160	125	45	54	22	4	140	24	M10	M10	180	1.5	160
200	125	50	72	32	4	140	32	M10	M10	235	2	200
250	200	60	72	32	5	224	32	M12	M12	305	3	250
315	200	75	80	36	5	224	36	M12	M12	355	6	304
350	260	75	91	37	5	286	36		M12	405	10	406
400	260	105	91	37	5	286	36		M12	455	10	406

Mounting Plates for 4 Jaw Metric Independent Chucks

Mounting plates are precision machined to suit the spindle nose of your machine and the appropriate chuck.

Spindle	160mm	200mm	250mm	315mm	350mm	400mm
D-3	8271-17222	8271-17222				
D-4	8271-17223	8271-17223	8271-25223			
D-5	8271-17224	8271-17224	8271-25224			
D-6			8271-25225	8271-25225	8271-32225	
D-8			8271-25226	8271-25226	8271-32226	8271-32226
D-11			8271-25227	8271-25227	8271-32227	8271-32227

Other adapter plates are available upon request. Specify chuck number and spindle nose specifications. For standard spindle dimensions, see page 28.

HOW TO ORDER: State quantity, model number of chuck, part number of adaptor, and shipping instructions.

3 Jaw Self-Centring Steel Body Scroll Chucks

Imperial Design

Series 332 Medium-Duty Flatback, A and D Type Mountings,
Sizes 500 to 2000mm

- Steel body
- Maximum .003" TIR using nominating pinion
- 0.001" repeatability using nominating pinion
- Two-piece American standard tongue and groove jaws
- Nitride hardened and ground scroll
- Three hardened pinions
- Twelve month warranty



Large King Bore Oil Country 3 Jaw Scroll Chucks

Imperial Design

Series 332 Medium-Duty Flatback, A and D Type Mountings,
Sizes 500 to 1000mm

- Steel body
- Extra heavy duty American standard, hard top and master jaws .
- Gripping surfaces serrated for more holding power
- Large through-holes standard
- Hardened scroll gear for long life
- Twelve month warranty

4 Jaw Independent Steel Body Chucks

Imperial Design

Series 432 Medium-Duty
Sizes 460 to 2000mm

- Two-piece reversible American standard tongue and groove jaws
- Hardened and ground operating screws
- Steel body
- T-slots standard
- Straight recess for adapter mounting
- Available in A-type & camlock mount
- Twelve month warranty



King Bore Oil Country 4 Jaw Independent Chuck

Imperial Design

Series 432EX Extra Heavy-Duty,
Sizes 460 to 1000mm

- Forged steel body
- Extra heavy duty American standard, hard top and master jaws.
- Gripping surfaces serrated for more holding power
- Large through holes as standard
- T-slots standard
- Direct A type & camlock mounting
- Twelve month warranty

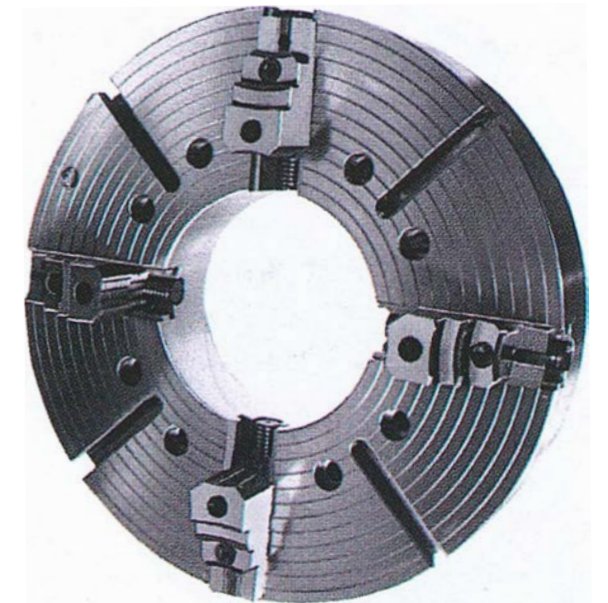

Pratt Burnerd International Gripfast 3 Jaw Power Chucks

Constant Grip Open Centre Power Chucks Sizes 6" (160mm) through 24" (610mm)

Quick Change Jaw System

With the half turn of a key, each jaw can be released, removed and replaced with a re-set second set of jaws that are locked in position, simply by returning the key to its original position. There is a positive feel and smoothness of action along with a physical indication that the jaw is correctly secured in the jaw-way. Each chuck is supplied with two sets of base jaws that can be exchanged in 40 to 60 seconds.

Additional sets of base jaws can be supplied suitable for your existing library of top jaws. If top jaws are left undisturbed then repeatability remains the same, whether simply operating the chuck or returning the jaws to the chuck hours or days later

- $\pm 1.2\mu\text{m}$ repeatability
- 3-Point adjusting feature in the chuck body permits indicating in to zero. Increase soft jaw life by using adjustment feature. Reduce or eliminate re-boring of soft jaws
- High RPM ... up to 6,000 using standard top jaws ... without loss of gripping force, due to internally counter-balanced design
- Quick change base jaws, 2 sets supplied with each chuck permits offline pre-assembly of top tooling for next job reducing traditional setup time by 95%
- SAFE visual Indicator shows when master jaws are in the unlocked mode
- Utilise existing top tooling by selecting style of master jaws from 1.5 x 60, 1/16 x 90, Am. Std. Acme, Am. Std tongue & groove and square serrations or substitute mono block jaws. Sets can be mixed styles
- Doubles as collet chuck as master jaws have keyed radius in front that accept standard W & S collet pads. Eliminate time wasted on switching over to collet chuck
- Large Bore Capacity
- Utilize the machine's existing actuating cylinder - does not require long stroke cylinder
- Easy installation - removable blank sleeve in the chuck allows the customer to bore and thread the sleeve of the chuck to match existing drawtube or drawbar. PBI can supply chuck sleeve pre-threaded on request, at a nominal charge
- Twelve month warranty



Setrite Adjustment

- Fast runout adjustment of chuck body or component if required
- Better and more consistent surface finish of the component
- Increased durability of tools
- Consistent quality standards
- User confidence in process and tools

Economics

It is only after you have purchased your CNC lathe that you become aware of lost production time and extra costs in fitting jaws.

	Rate	Set-up cycles per week	Minutes per set-up	Total minutes set-up per week	Working weeks per annum	Total set-up and lost machining time per annum	Total cost per week	Total cost per annum	Cash saved on your bottom line per year
Changing jaws on a standard power chuck	£65	5	15	75	46	3,450 mins (57.5 hrs)	£81.25	£3,737.50	£3,488.33
Using Gripfast chuck jaw method	£65	5	1	5	46	230 mins (3.83 hrs)	£5.42	£249.17	93% Saving

	Rate	Set-up cycles per week	Minutes per set-up	Total minutes set-up per week	Working weeks per annum	Total set-up and lost machining time per annum	Total cost per week	Total cost per annum	Cash saved on your bottom line per year
Removing a power chuck and fitting a collet chuck	£65	2	60	120	46	5,520 mins (92 hrs)	£130	£5,980	£5,830.50
Using Gripfast change chuck & collet pads	£65	2	1.5	3	46	138 mins (2.38 hrs)	£3.25	£149.50	98% Saving

Additional sets of base jaws can be supplied suitable for your existing library of top jaws. If top jaws are left undisturbed then repeatability remains the same, whether simply operating the chuck or returning the jaws to the chuck hours or days later.

6"	8"	10"	12"	15"	18"	20"	24"
8130-17623	8130-21623	8130-26623	8130-31623	8130-26623	8130-46623	8130-50623**	8130-61623**
8130-17610	8130-21610	8130-26610	8130-31610	8130-26610	8130-46610*	8130-50610*	8130-61610*
N/A	8130-21626	8130-26626	8130-31626	8130-26626	8130-46626	8130-50626	8130-61626
8130-17607	8130-21607	8130-26607	8130-31607	8130-26607	8130-46607	8130-50607	8130-61607
N/A	8130-21627	8130-26627	8130-31627	8130-26627	8130-46627	8130-50627	8130-61627
8130-17601P	8130-21601	8130-20227	8130-31601	8130-20227	8130-46601	8130-50601	8130-61601



Shown with optional jaw setting fixture and hard reversible top jaws. Jaw presetting fixture order number • 1009-07090 for use with 160mm to 610mm sizes Standard Bore and Large Bore High Speed Quick Change Jaw Power Chucks.

Insert last two digits for Master Jaw type. Example 9131-21723... Indicates 1.5mm x 60° : Master Jaw Required
 Use 23 for 1.5mm x 60° Japanese type.**
 Use 07 for Am. Std Tongue & Groove.
 Use 10 for 1/16 X 90° Serrations.*
 Use 26 for Acme Serration.
 Use 27 for Square Serration.

Pratt Burnerd International Self Contained MK4 3-Jaw Power Chucks

Turn your engine lathe into a production machine with this easy retrofit self-contained power chuck

- 12 months warranty
- Precision manufactured for adapter mounting plates
- Repetitive gripping within .001”T1R
- Safe, chuck operates independently of air supply when gripping
- No separate actuating cylinder
- No draw tube to restrict thru-hole
- Sizes 160mm, 200mm, 250mm & 315mm
- Suitable for chucking or barwork
- Less overhang, lighter in weight
- No ring adjustment needed
- Also available in 2 & 4 Jaw



Model	160MK4	200MK4	250MK4	315MK4
Inch Seriation (1/16"/90°) Order no. 3 jaw	9730-01710	9730-02110	9730-02610	9730-03210
Metric Seriation (1.5/60°) Order no. 3 jaw	9730-01723	9730-02123	9730-02623	9730-03223
Stroke per jaw mm	4	4	5	5
Max speed at 6 bar rpm	4500	3600	3500	2500

Pratt Burnerd International Accessories and Installation for MK4 SCPC

This unit is essential to order to operate MK4 self-contained power chucks. It is designed to be interlocked with the machine spindle so that the chuck cannot be actuated while the spindle is under power. Care must be taken not to actuate the chuck while the spindle is decelerating.

Units are supplied complete with pressure gauge, pressure regulator, oil mist lubricator, air filter and lines with fittings.

Unit is operated by air and 110 volt (24 volt DC on request).



Gripsafe

Chuck force measurement gripmeter

The new Gripsafe allows you to effortlessly measure your chuck gripping force - ensuring safety and peace of mind for operators, trainees and managers.

Under current H&S legislation, workholding equipment must be inspected and maintained regularly to ensure they remain safe and fit for purpose – IT IS YOUR RESPONSIBILITY.

The NEW Gripsafe solves this immediately, just grip and go.

Results are recorded quickly and easily through comprehensive measurement and analysis software that should be an essential part of your H&S maintenance programme.

Features

- Static & Dynamic chuck gripping force measurement
- Measures gripping force up to 100kN per jaw
- 3 & 2 jaw chuck compatibility
- Measures rotational speed up to maximum of 6000rpm
- Wi-Fi communications to any Wi-Fi compatible device
- Rechargeable battery with USB charging interface
- Extension rings to enable use with increased diameters
- No additional software required - application software embedded into GripSafe unit
- Battery level software indicator
- Real Time data capture
- Multiple machine file save feature
- Multiple machine session feature
- Data analysis functions
- Data export to .CSV file function
- Test certification print facility with automatic time and date stamping
- Automatic re-calibration reminder



Front Hand Wheel 5C Collet Chucks

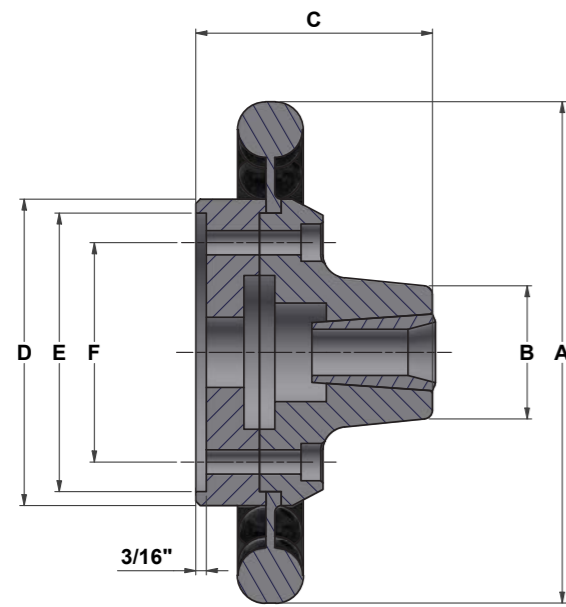

- Fast and easy, front hand wheel operation
- Reduces operator fatigue
- Quick change over chuck to collet chuck - no linkages or drawtubes
- For 5C collets (Max 5C Gripping Round 1.1/8")
- Twelve month warranty

- Accurate-maximum cone TIR .0005"
- Available in D type (camlock), A type, L type (long tapered nose) threaded, flat back and 4° taper
- Hand wheel teeth nitrided for longer life
- Body nickel plated for corrosion resistance

Plain Back Chuck Specifications

Item No.	Desc.	Collet Type	Round Cap.	A	B	C **	D	E	F	Weight
PB23-00	5C-PB	5C	1.06	9.0*	2.25	4.25	5.5	5.0	5.0	19

D Type Cam-Lock Chuck Specifications

Item No.	Spindle	Round Cap.	Maximum rpm
PB23-D3	D1-3	1.06	22
PB23-D4	D1-4	1.06	22
PB23-D5	D1-5	1.06	22
PB23-D6	D1-6	1.06	25
PB23-D8	D1-8	1.06	30
PB23-D11	D1-11	1.06	35

**Dimension C is chuck without spindle adapter mounting plate. Add approximately 1.125" to dimension C. If exact 'B' Dimension with mounting plate is required contact factory.

Front Hand Wheel 16C Collet Chucks

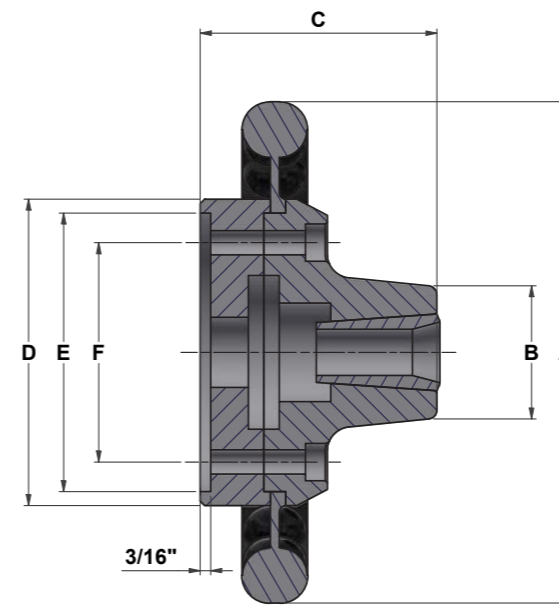

- Fast and easy, front hand wheel operation
- Reduces operator fatigue
- Quick change over chuck to collet chuck - no linkages or drawtubes
- For 16C collets (Max 16C Gripping Round 1-5/8")
- Twelve month warranty

- Accurate-maximum cone TIR .0005"
- Available in D type (camlock), A type, L type (long tapered nose) threaded, flat back and 4° taper
- Hand wheel teeth nitrided for longer life
- Body nickel plated for corrosion resistance

Plain Back Chuck Specifications

Item No.	Desc.	Collet Type	Round Cap.	A	B	C **	D	E	F	Weight
PB16-00	PB16C	16C	1.625	10	3.15	5.44	7.00	6.00	5.25	30

D Type Cam-Lock Chuck Specifications

Item No.	Spindle	Round Cap.	Maximum rpm
P816-D3	D1-3	1.625	36
PB16-D4	D1-4	1.625	36
P816-D5	D1-5	1.625	38
P816-D6	D1-6	1.625	38
P816-D8	D1-8	1.625	44
P816-D11	D1-11	1.625	52

Quick Change 5C Collet Chuck

Series No. COLSC

- Quickly change from chuck work to collet work
- Hold the collet chuck in your power or manual chucks
- Mount in vertical mills, horizontal mills and machining centres
- Drilled and tapped for fixture mounting
- Dead length
- Hardened and ground
- No set-up
- Hex key included
- Twelve month warranty Accurate-maximum cone TIR .0005"
- Ideal for short run production on CNC lathes. No tear down or change over
- Stack units for multiple part production



Air Powered Front Mount Dead Length Collet Chucks

No Draw-tube or Air Feed Tubes Required

- No hydraulic system required
- No drawtube or air feed tube restricting spindle bore
- No rear cylinders and cylinders adaptors
- Easily convert any lathe or grinder into a production machine Ideal for rotary table applications
- Change from collet chuck to standard chuck quick and easy High accuracy less than .001" TIA
- Repeats duplicate parts plus minus .0002"
- Dead length design
- For best accuracy use high quality collets
- Lever or foot pedal actuated
- Low maintenance with oil mist lubrication system
- High resistance to coolant and chip penetration
- Available with A, D, L, threaded and straight recess mounting plate Available in 5C, 16C 173E & 185E versions



OPTIONS: Order No: LEV100 Lever Control Package: (Includes: lever control, line filter, lubricator and regulator.)

Order No: FOT200 Foot Pedal Control Package: (Includes: foot pedal, line filter, lubricator and regulator.)

Spindle Conversion Adaptors Imperial Design

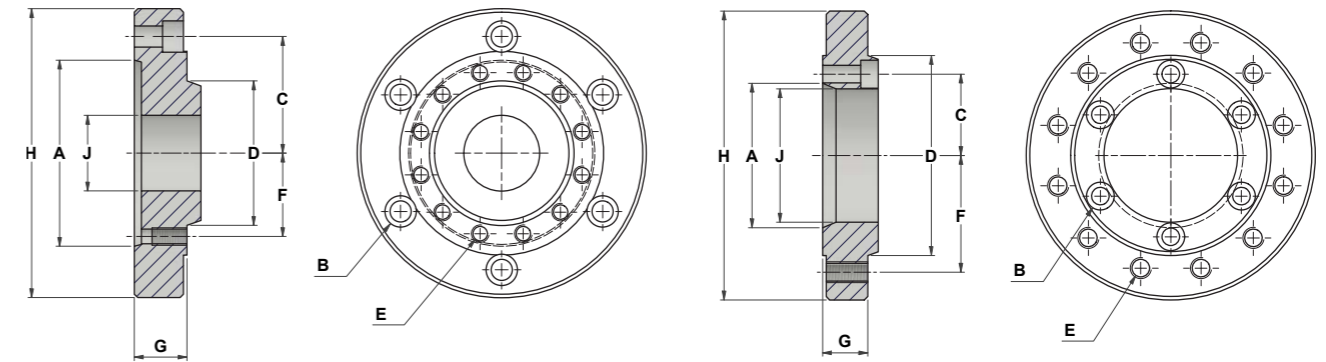

Part No.	Type	Mount	A	B (bolt) in*	B (bolt) mm*	C	Mount	D	E (tap) in	E (tap) mm		Offset G	Dia H	Hole J
A5-A6	2	5	3.250	7/16	10	4.125	6	4.188	1/2x13	12x1.75	5.250	1.000	6.500	2.500
A5-A8	2	5	3.250	7/16	10	4.125	8	5.500	5/8x11	16x2	6.750	1.125	8.250	3.000
A6-A5	1	6	4.188	1/2	12	5.250	5	3.250	7/16x14	10x1.5	4.125	1.500	6.500	1.700
A6-A8	2	6	4.188	1/2	12	5.250	8	5.500	5/8x11	16x2	6.750	1.125	8.250	3.250
A6-A11	2	6	4.188	1/2	12	5.205	11	7.750	3/4x10	20x2.5	9.250	1.375	11.000	4.000
A8-A6	1	8	5.500	5/8	16	6.750	6	4.18	1/2x13	12x1.75	5.250	1.750	8.250	2.500
A8-A11	2	8	5.500	5/8	18	6.750	11	7.75	3/4x10	20x2.5	9.250	1.375	11.000	5.250
A8-A15	2	8	5.500	5/8	16	6.750	15	11.2	7/8x9	22x2.5	13.000	1.625	15.000	5.250
A11-A6	1	11	7.750	3/4	20	9.250	6	4.18	1/2x13	12x1.75	5.250	1.750	11.000	2.500
A11-A8	1	11	7.750	3/4	20	9.250	8	5.50	5/8x11	16x2	6.750	1.875	11.000	3.250
A11-A15	2	11	7.750	3/4	20	9.250	15	11.250	7/8x9	22x2.5	13.000	1.625	15.000	7.500
A11-A20	2	11	7.750	3/4	20	9.250	20	16.250	1x8	24x3	18.250	1.875	20.500	7.500
A15-A8	1	15	11.250	7/8	22	13.000	8	5.500	5/8x11	16x2	6.750	2.000	15.000	3.250
A15-A11	1	15	11.250	7/8	22	13.000	11	7.50	3/4x10	20x2.5	9.250	2.250	15.000	5.250
A15-A20	2	15	11.250	7/8	22	13.000	20	16.250	1x8	24x3	18.250	1.875	20.500	11.000
A20-A11	1	20	16.250		24	18.250	11	7.750	3/4x10	20x2.5	9.250	2.125	20.500	5.250
A20-A15	1	20	16.250		24	18.250	15	11.250	7/8x9	22x2.5	13.000	2.500	20.500	8.250

*Specify metric or inch requirements when ordering

NOTE

1. Spindle and chuck mountings are outer bolt circle (type A2).
2. "A" and "D" are diameters to sharp corners (large diameter of taper)
3. "B" bolts are a total of 6 equally spaced (60 deg. apart) on a bolt circle of "C".
4. "E" tapped holes are a total of 12 equally spaced (30 deg. apart) on a bolt circle of "F".
5. See standard spindle dimensions on page ??

- Made from steel
- Dimensions are per USA standards
- Available with UNC or metric mounting bolt holes

Chuck Lubricant for Manual and Power Chucks

This is a specially formulated high pressure Chuck Lubricant and is the recommended lubricant to be used in all Pratt Burnerd Chucks that require grease type lubrication.

Ordering Information:

Order No.	Description
PB16OZ	16 oz (453.6 gms) tube
PB10LB	10 lb (4.5 kilo) tub





FOR FURTHER INFORMATION OR TO REQUEST A DEMONSTRATION
PLEASE CONTACT OUR SALES TEAM 02 9674 4738 | sales@colchestermachines | colchestermachines.au

27 Foundry Road | Seven Hills | NSW 2147



Certificate No. QEC20541