

# MODEL RANGE

FL510 4x2 Platform 10 tonne - Rear Air Suspension FL 42 R 510A

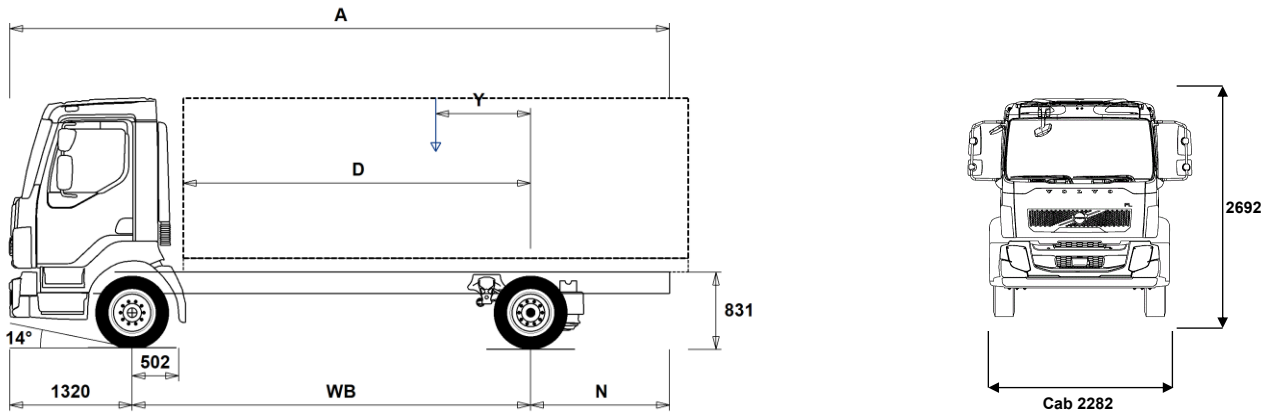

## Chassis Dimensions [mm]

| WB Wheelbase                           | 3500 | 3800 | 4100 | 4400 | 4700 | 5000 | 5300 | 5600  | 5900  | 6200  | 6500  |
|--|------|------|------|------|------|------|------|-------|-------|-------|-------|
| A Overall Chassis Length               | 6975 | 7425 | 7955 | 8425 | 8915 | 9435 | 9915 | 10425 | 10835 | 11430 | 11730 |
| D Center of rear axle to front of body | 2948 | 3248 | 3548 | 3848 | 4148 | 4448 | 4748 | 5048  | 5348  | 5648  | 5948  |
| N Rear Overhang (Min.)                 | 2055 | 1885 | 2445 | 2635 | 2835 | 2895 | 2895 | 3415  | 3295  | 3505  | 3755  |
| N Rear Overhang (Max.)                 | 2155 | 2305 | 2535 | 2705 | 2895 | 3115 | 3295 | 3505  | 3615  | 3910  | 3910  |
| Y Center of Gravity for Payload (Min.) | -281 | -307 | -332 | -360 | -388 | -426 | -455 | -485  | -501  | -548  | -584  |
| Y Center of Gravity for Payload (Max.) | 652  | 709  | 768  | 824  | 882  | 936  | 993  | 1050  | 1114  | 1165  | 1216  |

## Chassis Weights [kg]

|  |      |      |      |      |      |      |      |      |      |      |      |
|--|------|------|------|------|------|------|------|------|------|------|------|
| Front Axle                                   | 2880 | 2885 | 2885 | 2885 | 2890 | 2900 | 2905 | 2905 | 2895 | 2910 | 2920 |
| Rear Axle                                    | 1120 | 1130 | 1150 | 1165 | 1190 | 1225 | 1240 | 1255 | 1260 | 1295 | 1300 |
| Kerb Weight                                  | 4000 | 4015 | 4035 | 4050 | 4080 | 4125 | 4145 | 4160 | 4155 | 4205 | 4220 |
| Payload (including body, driver, fuel, etc.) | 6000 | 5985 | 5965 | 5950 | 5920 | 5875 | 5855 | 5840 | 5845 | 5795 | 5780 |

## Turning Diameter [mm]

|                                      |       |       |       |       |       |       |       |       |       |       |       |
|--------------------------------------|-------|-------|-------|-------|-------|-------|-------|-------|-------|-------|-------|
| Turning Circle Diameter Kerb to Kerb | 12300 | 13200 | 14100 | 15000 | 15900 | 16800 | 17700 | 18600 | 19500 | 20400 | 21300 |
| Turning Circle Diameter Wall to Wall | 13700 | 14600 | 15500 | 16400 | 17300 | 18200 | 19100 | 20000 | 20900 | 21800 | 22700 |

## Plated Weights [kg]

|                          | Plated | Design |
|--------------------------|--------|--------|
| Gross Vehicle Weight     | 10000  | 10000  |
| Gross Combination Weight | 0      | 15500  |
| Front Axle               | 4000   | 4000   |
| Rear Axle                | 7600   | 7600   |

## Important Notes

### Chassis Dimensions

Cab Height: +39 mm for CAB-CRW.  
 Front Axle to Back of Cab: +1294 mm for CAB-CRW, +316 mm for CAB-SSLP.  
 D-measure includes a front clearance of 50 mm and for rigid trucks also a subframe of 120 mm.  
 Height can vary ± 20 mm for leaf and ± 10 mm for air suspension.  
 All dimensions are for unladen chassis and any tag axles down.

Weight and dimensions are based upon the following tyres:  
 Front Axle Tyres: 235/75R17.5  
 Drive Axle Tyres: 235/75R17.5

Chassis weight includes oil, water, AdBlue, 0 litres fuel and without driver. Kerb weight can vary ± 3%.

Turning diameters are theoretically calculated.

Legal weights can differ from country to country.

For more detailed weight information, including optional equipment weights, ask your Volvo sales contact to enter your specification into the Volvo Weight Information system (WIS).

Do NOT use this drawing for bodybuilding. Refer to Volvo Bodybuilder Instructions and chassis assembly drawing FL42R510A.

# MODEL RANGE

FL510 4x2 Platform 10 tonne - Rear Air Suspension FL 42 R 510A

## TRUCK USE

- **UNIFORM** Transport Adaption - Basic platform vehicle

## CORE COMPONENTS

- **CHH-LOW** Chassis height - Low - for loading heights check the unique BEP chassis drawing attached to this quote
- **RAD-A2V** Rear suspension - Two bag rear air suspension
- **FL-CREW2** Cab - Four door six person crew cab
- **FL-DAY2** Cab - Day, with steel safety cage design. Designed and built to Swedish impact and ECE R29 regulations
- **FL-SSLP2** Cab - Comfort with additional storage space or optional fold up bunk behind the driver - with steel safety cage design. Designed and built to Swedish impact and ECE R29 regulations.
- **EU6SCR** Emission level - Euro VI step E
- **D5K210** Engine - D5K210 four-cylinder 5.1 litre developing 210hp at 2200rpm. Peak torque 800Nm at 1100-1700rpm.
- **D5K240** Engine - D5K240 four-cylinder 5.1 litre developing 240hp at 2200rpm. Peak torque 900Nm at 1100-1600rpm.
- **ATO1056** Gearbox - Automated 6-speed I-sync overdrive - if the truck is built from week 47 an 8 speed ZF powerline automatic.
- **ATO8006** Gearbox - Automated 6-speed I-sync overdrive - if the truck is built from week 47 an 8 speed ZF powerline automatic.
- **STO8006** Gearbox - Manual 6-speed overdrive
- **ZTO1006** Gearbox - Manual 6-speed overdrive
- **EBR-EPG** Engine brake type - Exhaust brake controlled by steering column switch
- **RSS0819A** Drive axle - RSS0819A single reduction with differential lock Design GCW 18.75 tonne

## Packages

- **DRIVEFL** Cab Package - Drive
- **VISIFL** Visibility package
- **AIRFLOW** Airflow Package
- **AUDIODAB** Audio System - Digital DAB AM/FM Radio with Bluetooth - without CD player
- **AUDIOPD** Audio - Preparation for DAB radio including amplifier and aerial

## CHASSIS

- **FST-PAR** Front suspension - Parabolic front springs with shock absorbers and anti-roll bar
- **EBS-MED** Brake package - EBS medium including traction control & hill hold
- **EBS-STD** Brake package - EBS standard package without traction control - Without
- **RST-AIR** Rear suspension - Air
- **SUSPL-E1** Air suspension levelling control - Remote control on wander-lead
- **SUSPL-E3** Air suspension levelling control - Integral dash switches
- **FST6060** Chassis frame thickness - 6 mm web and flange
- **FST7070** Chassis frame thickness - 7 mm web and flange
- **FST8080** Chassis frame thickness - 8 mm web and flange
- **2BATT170** Battery Capacity - 2 x 170 Ah on the left-hand side
- **ADR2** ADR Adaptation - For transportation of dangerous goods on the road - Note does NOT include safe loading pass package if required this is quoted separately
- **R215P** Right fuel tank - 215-litre plastic  
Min volume 80l  
Max volume 430l
- **UL-FUEL** Left fuel tank - Without
- **ADTP-R** Adblue tank position - Chassis mounted on the right-hand side

- Standard Equipment
- Optional Equipment

For more detailed information about cab and powertrain equipment, please refer to separate specification sheets.

For all possible options and combinations of options please consult your Volvo sales contact who can create a specification to match your requirements using the Volvo Sales Support system (VSS).

The factory reserves the right to modify design and change equipment without previous notification. The specification can vary from country to country.

- **WHC-FIX1** Wheel chock - One fixed design
- **WHC-FIX2** Wheel chocks - Two fixed design
- **TOWMBRH** Tow member - High mounted in centre of frame - Check the GCW in the "Truck Use" section of this specification
- **C-RO40AG** Drawbar coupling - Rockinger 400 G145
- **TOWF-NO1** Front towing device - One pin in bumper
- **TOWF-NO2** Front towing device - Two pins in bumper
- **TOWR-ONE** Rear cross member towing eye - Capacity 3tonne at 20mph
- **TREL15** Trailer electrical connection - Single 15 pin - ADR certified
- **TBC-EC** Trailer brakes with EC palm coupling connectors
- **RUP-FIX2** Rear underrun protection - Fixed EC approved
- **RFEND-T** Rear mud wings - Temporary on drive axle for transport delivery only

## WHEELS & TYRES

- **RT-ALDP** Wheels - Howmet Alcoa Dura-Bright aluminium rims - standard holes for long stud fixing
- **RT-STEEL** Wheels - Steel rims
- **SPWT-F** Spare wheel & tyre - Spare with front tyre pattern
- **SWCP-LF** Spare wheel carrier on left side of chassis ahead of rear axle
- **SWCP-R** Spare wheel carrier rear mounted below frame.
- **SWCP-T** Spare wheel supplied temporarily strapped to chassis
- **SWCP-TP** Spare wheel carrier transport mounted on frame (spare wheel carrier not included)
- **JACK-6T**
- **GAUGE-TP** Tyre pressure gauge

## DRIVELINE EQUIPMENT

- **CS39A-O** Clutch - Single plate 395mm (16")
- **TC-HWO** Transmission oil cooler - water to oil
- **1COMP500** Air compressor - Single cylinder 360 cc - 500 litres per minute
- **AIRIN-FR** Air intake - Under the front grille - Left-hand drive only
- **AIRIN-HI** Air intake - Mounted behind cab on the left-hand side
- **AIRIN-RL** Air intake - Chassis mounted behind cab on the left-hand side
- **ACL1ST** Air filter - Single element
- **ACL1ST-S** Air filter - two-stage element
- **24AL110B** Alternator capacity - 110 amp
- **24AL130B** Alternator capacity - 130 amp
- **CCV-C** Closed crankcase ventilation
- **CCV-OX** Open crankcase ventilation with oil separator and a maintenance free gas centrifuge
- **EST-AID** Engine starting aid -Preheating element in the air inlet manifold
- **PTER-100** Engine power-take-off - Rear-mounted with DIN100/ISO7646 flange
- **PTER-DIN** Engine power-take-off - Rear-mounted with DIN5462 (female) splined shaft for a close-coupled pump
- **PTER1400** Engine power-take-off - Rear-mounted with SAE 1410 flange
- **PR-HF4S** Live-drive PTO for Allison gearbox output 400Nm for flange connection mounted on the side of the torque convertor
- **PR-HF4SH** Live-drive high speed PTO for Allison gearbox output 400Nm for hydraulic pump connection mounted on the side of the torque convertor
- **PR-HF6S** Live-drive PTO for Allison gearbox output 600Nm for flange connection mounted on the side of the torque convertor
- **PR-HP4S** Live-drive PTO for Allison gearbox output 400Nm for hydraulic pump connection mounted on the side of the torque convertor
- **PR-HP4SH** Live-drive high speed PTO for Allison gearbox output 400Nm for hydraulic pump connection mounted on the side of the torque convertor

# MODEL RANGE

FL510 4x2 Platform 10 tonne - Rear Air Suspension FL 42 R 510A

- **PR-HP6S** Live-drive PTO for Allison gearbox output 600Nm for hydraulic pump connection  
mounted on the side of the torque convertor
- **PTR-FH5** Rear PTO Gearbox S88 flange DIN connection
- **PTR-PH4** Rear PTO Gearbox S88 pump DIN connection
- **HPG-F101** Gearbox mounted hydraulic pump - Parker F1-101 hydraulic pump gearbox mounted
- **HPG-F41** Gearbox mounted hydraulic pump - Parker F1-41 gearbox mounted, fixed displacement, single flow
- **HPG-F51** Gearbox mounted hydraulic pump - Parker F1-51 gearbox mounted, fixed displacement, single flow
- **HPG-F61** Gearbox mounted hydraulic pump - Parker F1-61 gearbox mounted, fixed displacement, single flow
- **HPG-F81** Gearbox mounted hydraulic pump - Parker F1-81 gearbox mounted, fixed displacement, single flow
- **ETC** Electronic throttle control - dash mounted switch for PTO speed control

## CAB INTERIOR

- **STWPOS-L** Steering wheel position - LEFT-HAND DRIVE
- **STWPOS-R** Steering wheel position - RIGHT-HAND DRIVE
- **TAS-DIG4** Smart tachograph - Continental VDO 4.1 version 2 - legal demand from 21/08/2023
- **DAS-W2** Driver Alert Support with driver attention monitoring to comply with EU GSR2 step 2 regulations
- **TSRS** Intelligent speed assist & road sign recognition

## CAB EXTERIOR

- **SUNV-B** Exterior sun visor - Smoked grey
- **SUNV-PK** Exterior sun visor preparation kit only
- **AD-SIDES** Cab side deflector - Short extension panels
- **BEACON-P** Roof beacons - switch and wiring preparation only
- **BEACONA2** Roof-mounted beacons - Two LED amber beacons mounted direct on roof

## SUPERSTRUCTURE PREPARATIONS

- **FBA-BTF** Lower front body attachments - For torsionally flexible - platform body
- **FBA-BTSF** Lower front body attachments - For torsionally semi-flexible body - box or curtainsider
- **RBA-T2** Rear body attachments - Divided
- **TAILPREP** Taillift preparation kit - cab switch and warning in driver display

## DELIVERY SERVICES

- **TGW-4G** Telematics gateway - GSM/GPRS/4G modem, WLAN
- **WVTA** Whole Vehicle Type Approved - First stage chassis cab