

ORG

Semi-Automatic Bulk Butter Filling Machine



EGLI  **FASA**

PROCESSING TECHNOLOGY SINCE 1888

PACKAGING TECHNOLOGY SINCE 1959



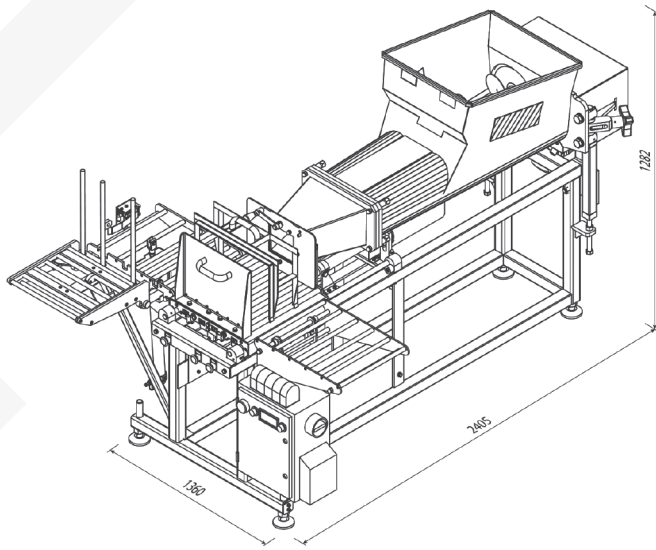

ORG is a semi-automatic filling machine designed for the bulk filling of butter/margarine in cartons.

Digital scales for weight control, automatic, pneumatic cutter and pneumatic box pushing off device options available.

TECHNICAL DATA

Machine type	semi-automatic, auger
Maximum output, cartons/h	100
Recommended temperature of butter/margarine, °C	9 – 16
Dosing range, kg	5; 10; 15; 20; 25
Output control	step-less
Inner size of the box*, mm	5 kg – 230 x 195 x 125 10 kg – 230 x 195 x 255 15 kg – 380 x 253 x 187 20 kg – 380 x 253 x 250 25 kg – 380 x 253 x 290
Number of augers	2
Air consumption, m ³ /h	0,22
Air compression, MPa	0,6
Rated power input, kVA	3
Voltage, V	230/400 ± 10% AC
Frequency, Hz	50/60
Dimensions (L x W x H), mm	2405 x 1360 x 1282
Approx. weight, kg	350

*Box size calculated to the density of 915 kg/m³

