

SERIES DPU

The easy to assemble High Torque/High Misalignment Solution

Maximum torque capacity: up to 23100 Nm - Bore Capacity: up to 220 mm

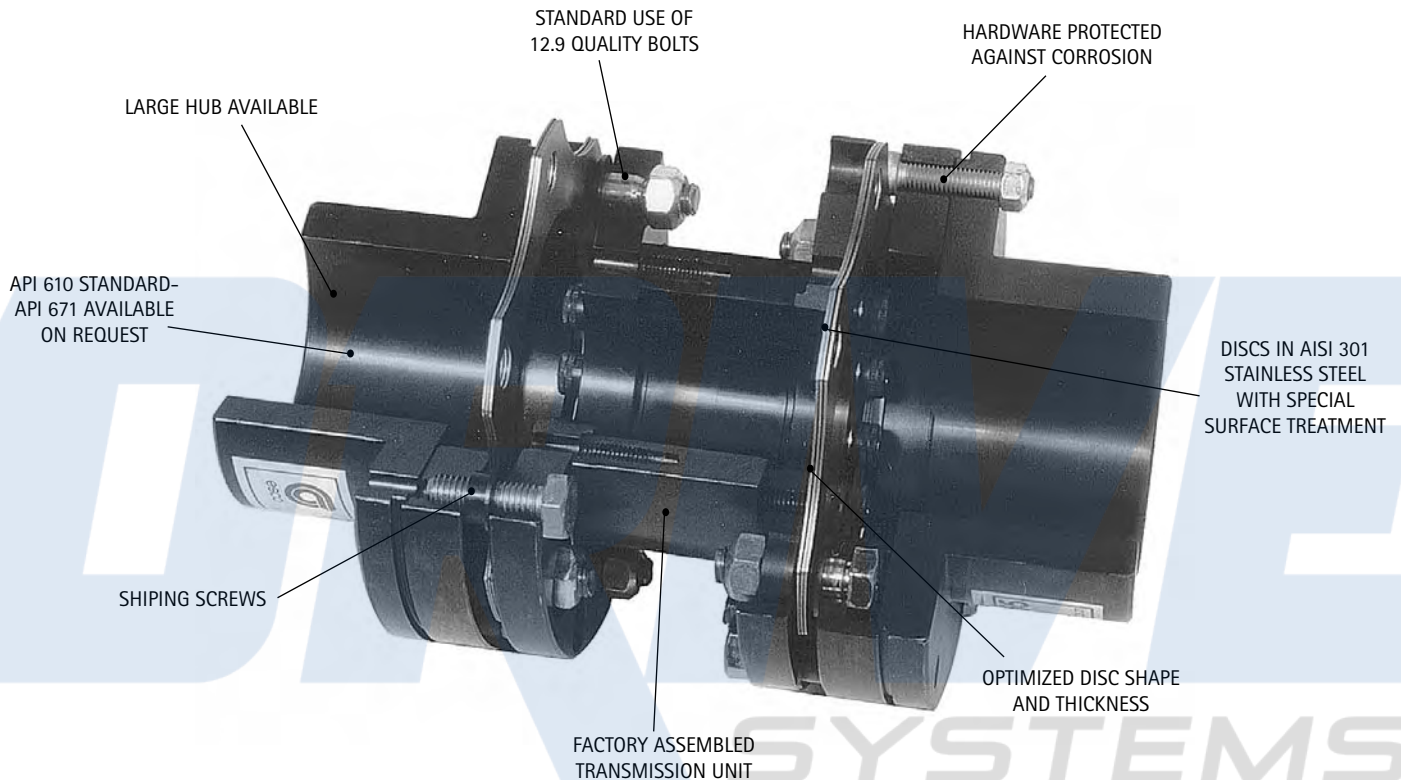

Easy assembly and disassembly

Thanks to the standard use of shipping screws and the factory assembled transmission unit, Escodisc DPU couplings combine the high torque and misalignment capacity of the DMU couplings with easiness of assembly. On average users can cut down assembly and disassembly costs by 50% when using Escodisc DPU couplings. Furthermore, because the transmission unit is factory assembled, the risk for assembly errors is reduced to an absolute minimum level which results in reliable operation and extended life of the coupling.

High Speed/Long DBSE applications

Thanks to the concept of the DPU coupling range (centring spigots) and the high manufacturing standards, it is ideal for use in medium to high speed applications with no or minor modifications. Furthermore, thanks to the perfect centring of the transmission unit, it can be used in applications where a long DBSE is required (e.g. cooling towers) and it can be adapted to meet the API 671 requirements.

Large Bore Capacity

The Large Hub execution (L-hub) of the Escodisc DPU series makes selection virtually independent of the shaft size which makes it possible in several applications to downsize compared with DLC or DMU type couplings.

Escodisc Series DPU - Quick Selection Table

Coupling size	Maximum Power (kW)															Max. Speed (Rpm)	Max. Bore	
	1000 Rpm			1500 Rpm			1800 Rpm			3000 Rpm			3600 Rpm				S-Hub (mm)	L-Hub (mm)
	SF 1	SF 1,5	SF 2	SF 1	SF 1,5	SF2	SF 1	SF 1,5	SF2	SF 1	SF 1,5	SF2	SF 1	SF 1,5	SF2			
DPU 38-60	20	13	10	30	20	15	36	24	18	60	40	30	72	48	36	24000	45	60
DPU 45-70	35	23	17	52	35	26	62	41	31	104	69	52	124	83	62	20400	55	70
DPU 55-80	79	52	39	118	79	59	141	94	71	236	157	118	283	188	141	18000	65	80
DPU 65-100	139	93	70	209	139	104	251	167	125	418	279	209	501	334	251	15000	75	100
DPU 75-110	230	154	115	346	230	173	415	276	207	691	461	346	829	553	415	12900	90	110
DPU 85-130	366	244	183	550	366	275	660	440	330	1099	733	550	1319	880	660	10800	105	130
DPU 95-145	696	464	348	1044	696	522	1253	836	627	2089	1393	1044	2507	1671	1253	9600	105	145
DPU 110-160	979	653	490	1469	979	734	1762	1175	881	2937	1958	1469	3525	2350	1762	8400	120	160
DPU 125-180	1330	887	665	1995	1330	997	2394	1596	1197	3990	2660	1995	4887	3192	2394	7500	135	180
DPU 140-200	1738	1159	869	2607	1738	1304	3129	2086	1564	5215	3476	2607	6258	4172	3129	6900	160	200
DPU 160-220	2149	1613	1075	3626	2149	1813	4358	2906	2179	7624	4843	3812	8719	5811	4359	6000	185	220

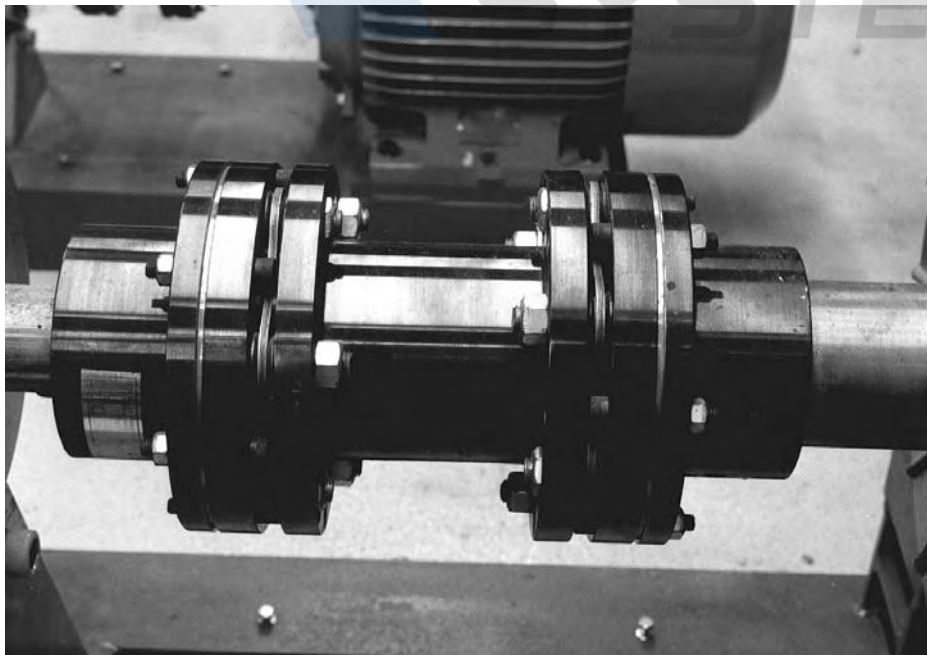

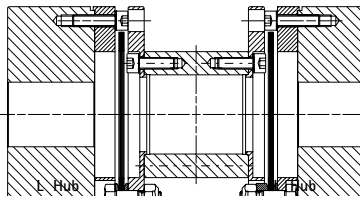

DPULL

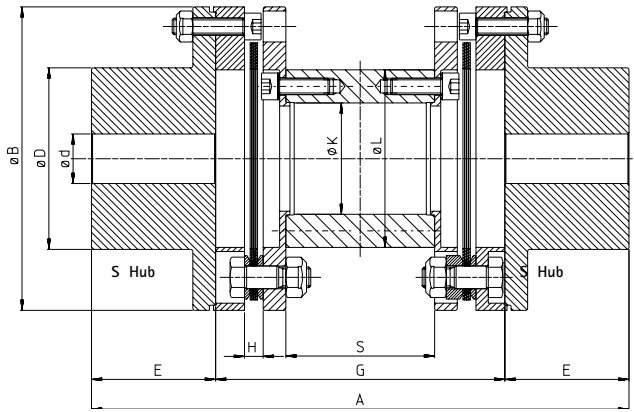

DPUSS

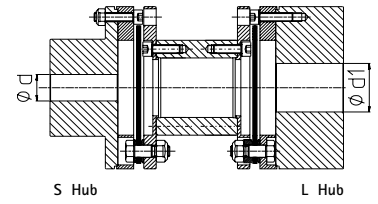

DPUSL

← A105			Type DPU											
			38-60	45-70	55-80	65-100	75-110	85-130	95-145	110-160	125-180	140-200	160-220	
	\varnothing max. \varnothing min.	1	mm	45	55	65	75	90	105	105	120	135	160	185
				0	0	0	25	32	38	45	55	65	65	80
	\varnothing max. \varnothing min.	1	mm	60	70	80	100	110	130	145	160	180	200	220
				0	0	0	25	32	38	45	55	65	65	80
	$\frac{N}{m}$	2.1	Nm	190	330	750	1330	2200	3500	6650	9350	12700	16600	23100
				290	500	1120	2000	3320	5200	10000	14000	19100	24900	34650
	min.max.	3	tr/min omw/min rpm min ⁻¹	8000	6800	6000	5000	4300	3600	3200	2800	2500	2300	2000
				24000*	20400*	18000*	15000*	12900*	10800*	9600*	8400*	7500*	6900*	6000*
	degré grad degree Grad	12		2x0,75	2x0,5	2x0,5	2x0,5	2x0,5	2x0,5	2x0,33	2x0,33	2x0,33	2x0,33	2x0,33
		12	mm: ±	2,4	2	2,6	2,8	3,2	4	2,5	2,8	2,6	3	3,4
		12	mm: ±	0,6	0,6	0,6	0,9	0,8	1,1	1	1,4	1,4	1,4	1,4
		4	kgm ²	0,003	0,0057	0,015	0,033	0,07	0,145	0,259	0,475	0,775	1,3	2,39
		5	kg	3,54	5,49	9,07	14,8	22,8	36,35	47	71,7	94,2	128	179
mm ±	A	11	mm	170	190	200	260	280	350	370	470	500	530	570
	B		mm	88	102	123	147	166	192	224	244	273	303	340
	D		mm	58,5	69,5	82	97,5	113	132	133	154	175	196	228
	E		mm	35	45	50	60	70	85	95	110	125	140	160
	G	11	mm	100	100	100	140	140	180	180	250	250	250	250
	H		mm	7,1	6,5	7	9	10	13	14	15,5	19	20	20
	K		mm	21	37	48	54	65	76	94	108	123	143	165
	L		mm	41	61	72	86	98	116	134	156	171	191	221
	S	11	mm	51,8	53	40	72	54	82	74	122	111	99	89

4 bolts <

6 bolts

> <

8 bolts

>

*Balancing needed - Consult us - • For DPUSS

Torque Capacity (Nm)

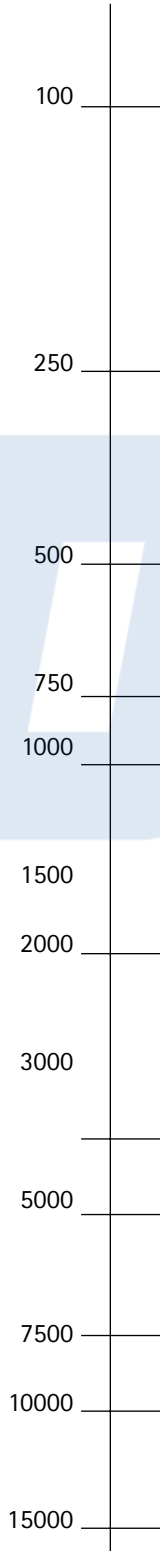

Escodisc DPU	Flender ARH	John Crane Flexibox Metastream TSKS	Jaure Lamidisc DO-6	Wellman Bibby Euroflex DJ	Kopflex KD2	Rexnord Thomas Series 71
38-60	96-6	0013	110-6	62	053	150
						175
45-75	120-6	0033	132-6	82	103	225
						300
55-80	142-6	0075	158-6	102	153	350
						375
65-100	162-6	0135	185-6	103	203	412
						462
75-110	190-6	0230	202-6	122	253	512
						562
85-130	214-6	0350	228-6	142	303	600
						712
95-145	230-6	0500	255-6	162	353	800
110-160	245-6	0740	278-6	163	403	
125-180	275-6	0930	302-6	192	453	
140-200	310-6	1400		193	453	
	345-6			232		