

PINECONE PINION

Coffee grinder

User manual

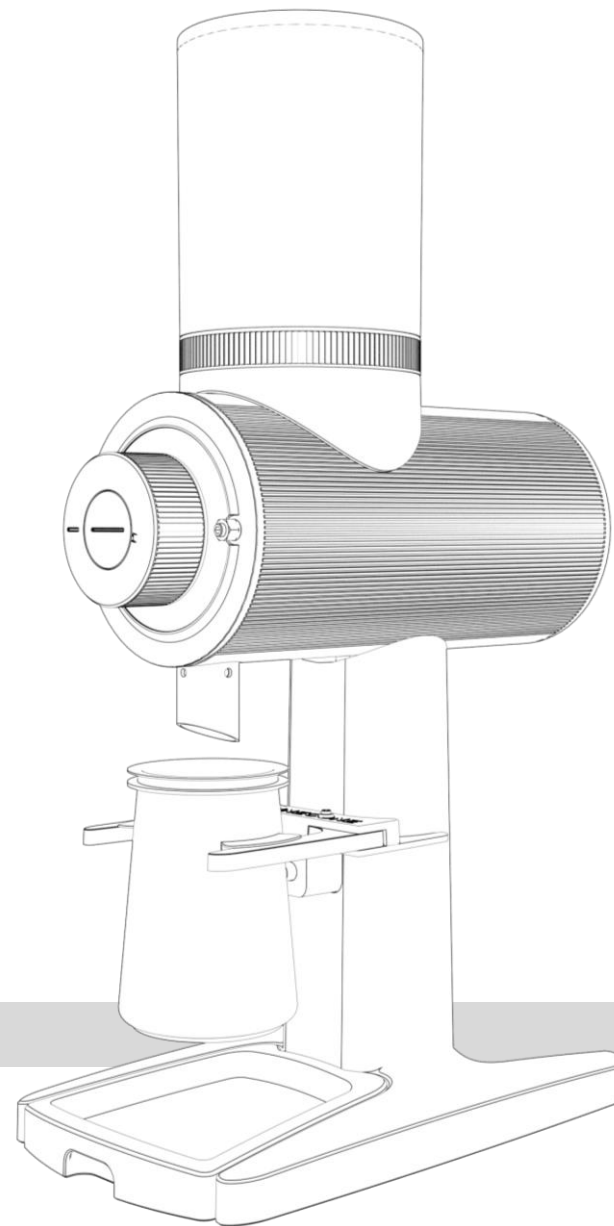

English

Overview

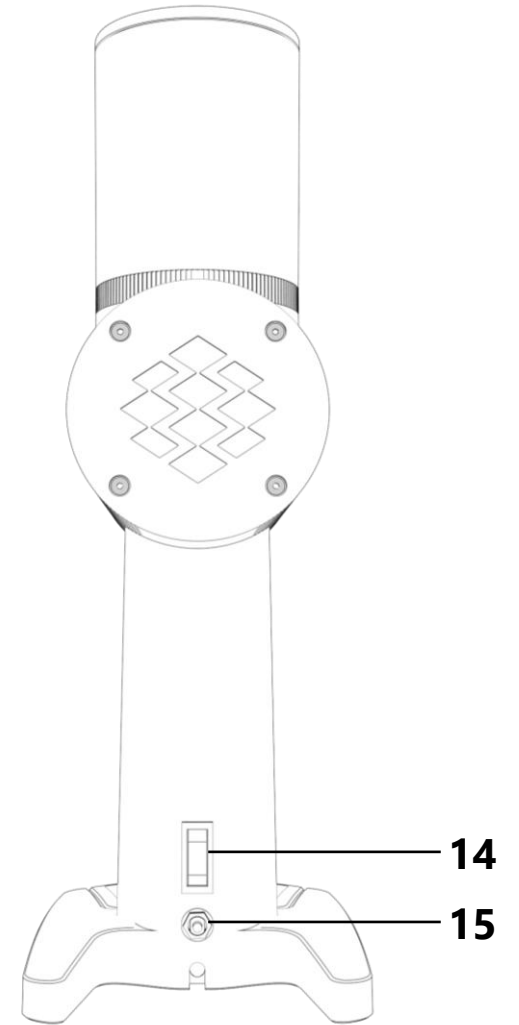
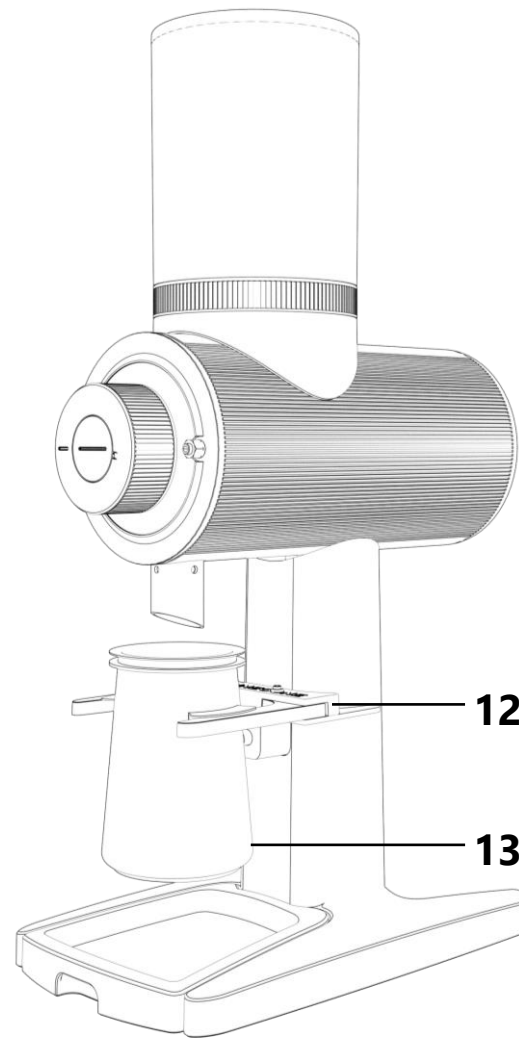
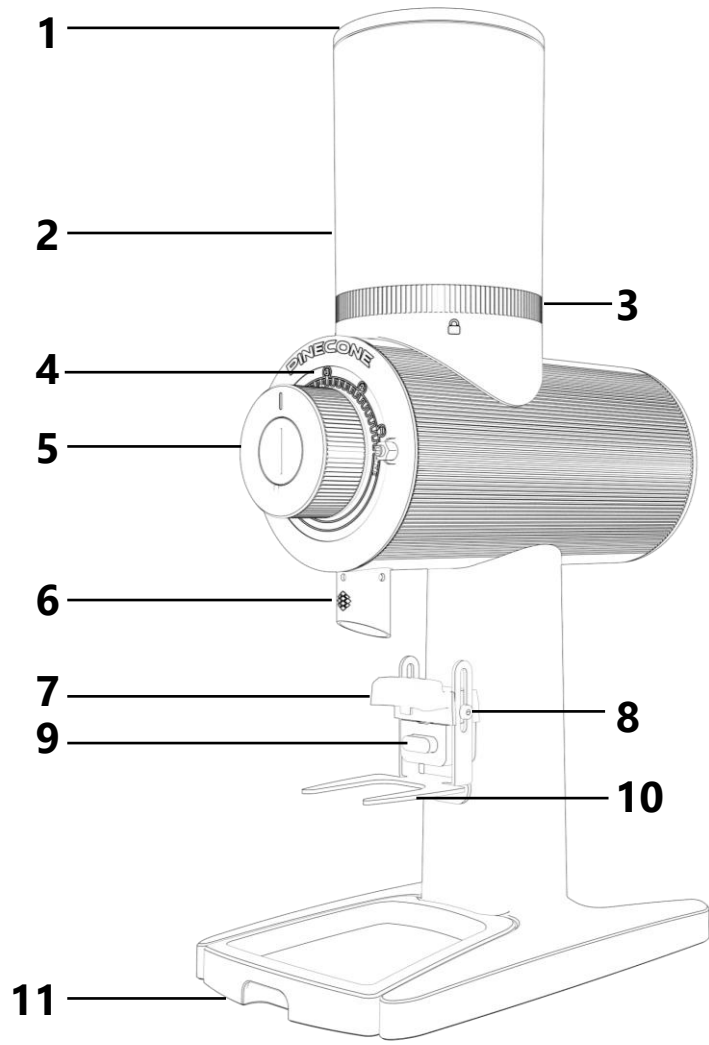

Delivery scope

1. Bean hopper lid
2. Bean hopper
3. Hopper lock ring
4. Grind size scale
5. Grind size adjustment knob
6. Spout
7. Portafilter holder
8. Portafilter support adjustment screw
9. Demand button
10. Portafilter support
11. Drip tray
12. Dosing cup holder platform
13. Dosing cup
14. On/Off switch
15. Overcurrent protector

Contents

General information	5	Maintenance	18
Reading and retaining the instruction manual	5	Replacing the grinding discs	18
Glossary and explanation of symbols in the instruction manual	5	Replacing the flapper	19
Safety	6	Troubleshooting	20-21
Intended use	6	Technical data	22
Safety information	7-8	Disposal	23
Before initial operation	9	Support & Service	23
Functioning and basic settings	9		
Validating the grinder and scope of delivery	9		
Setting up the grinder and inserting the bean hopper	10		
Setting up the portafilter	10		
Operation	11		
Filling the hopper with coffee beans	11		
Switching on the grinder	11		
Setting and changing the grind size	11		
Starting the grinding process	12		
Changing coffee beans	13		
Cleaning	14		
Cleaning the grinder installation surface	14		
Cleaning the grinder auxiliary components	15		
Cleaning the bean hopper	16		
Cleaning the grinding mechanism with GRINDZ	16		
Cleaning the grinding mechanism manually	17		

General information

Reading and retaining the instruction manual

Carefully read this instruction manual and safety information before using the described Pinion coffee grinder to ensure safe operation without danger. This manual applies standards and regulations in force in the European Union. Consultation of specific country laws and guidelines if abroad remain in the responsibility of the user.

The Pinion coffee grinder will hereafter be referred to only as “grinder” for simplicity. Keep this instruction manual for future reference and pass it on to subsequent owners and users of this grinder.

Glossary and explanation of symbols in the instruction manual



WARNING! Hazard of medium risk which can lead to death or serious injury if not avoided.



CAUTION! Hazard of low risk which can lead to death or serious injury if not avoided.



WARNING!
Electrical shock hazard.



Note!
Material damage possible.



Important information for operation & handling.



Product is permitted for indoor use only.



Mark to indicate a product that meets the electrical safety requirements in the United States of America.



Mark to indicate a product that meets the hygiene and cleanliness requirements in the food industry defined by the National Sanitation Foundation.



Mark to declare product conformity to applicable provisions of the European Economic Area.



Mark to declare product conformity to protection class I.

Safety

Intended use

The grinder is only suitable to grind whole roasted coffee beans. Do not use the grinder to grind other substances or objects.

The grinder is intended for commercial use but not for continuous mass production. Servicing the grinder is permitted exclusively for trained personnel. Operation by untrained persons is permitted in a place where its use is supervised.

Any other use is considered out of compliance with intended use and may result in material damage or personal injury.

Do not alter the grinder in any way. The manufacturer or supplier cannot be held liable for damages or any injuries resulting from failure to comply with safety instructions.

Safety information.



WARNING!

Danger of electric shock (1/2)

Improper use, incorrect electrical installation or excessively high voltage can lead to electric shock. Therefore:

- Connect the grinder only if the mains voltage of the socket complies with the information indicated on the type plate.
- Connect the grinder only to a socket with good accessibility so that it can be quickly disconnected in the event of a fault.
- Do not use the grinder if you notice any damage or if the power cable or plug is faulty. A damaged cable or plug must be replaced by the manufacturer or by qualified service personnel in order to avoid hazards.
- Do not operate the grinder without an earth connection.
- Connect the grinder only if the power supply is secured with a 16 A slow fuse or 15 A overload protection (USA). Only qualified electricians may install protective measures if the power connection at the site of use is not yet secured in this way.

Safety



WARNING!

Danger of electric shock (2/2)

- Always switch off the grinder (main switch (14) in 0 position) before you remove the power plug.
- Install the grinder only in places where handling & operation of the grinder can be supervised by trained personnel.
- Do not operate the grinder above 2,000 meters.
- Do not immerse the grinder or the power cable or power plug in water or any other liquids.
- Do not clean the grinder with a water jet or with compressed air (e.g. with a compressed air gun).
- Never touch the power plug with wet hands.
- Never unplug the power plug from the wall socket by pulling on the power cable; always grip the plug itself.
- Never use the power cable as a handle to carry the grinder.
- Keep the grinder and power cable/power plug away from open flames and hot surfaces.
- Position the power cable in a way so that it does not become a trip hazard.
- Do not bend the power cable and do not place it over sharp edges.
- Use the grinder in indoor areas only. Never operate the grinder in damp rooms or in the rain.
- Keep children away from the grinder and ensure that children do not insert any objects into the grinder.
- If you are not using the grinder, if you are cleaning it or if a fault occurs: switch off the grinder and remove the power plug from the socket.
- Do not open the grinder casing and delegate repairs and service to trained service personnel.
- All liability and warranty claims will be rejected and excluded in the event of unauthorized repairs, faulty power connection or incorrect grinder operation.
- Only OEM parts that comply with the original appliance specifications may be used for repairs and service. This grinder contains electrical and mechanical parts that are essential for protection against potential hazards.

Safety



WARNING! Danger for children and persons with reduced physical, sensory or mental capabilities (e.g. partially disabled or elderly persons) or a lack of experience or knowledge (e.g. older children or inexperienced users).

- The grinder is not intended for use by children or people with limited physical, sensory or mental abilities or a lack of experience and knowledge. Children may not play with the grinder.
- Do not leave the grinder unsupervised when in operation.
- Do not let children play with packaging film. Children can become entangled in it while playing and may suffocate.
- Do not let children play with the small parts. These can be life-threatening if swallowed.



WARNING! Risk of injury!
Accidentally reaching into the rotating grinding discs can cause serious injuries.

- Do not under any circumstances reach into the grinder, grinding house or grinder spout with bare fingers.
- Do not insert any objects into the grinder.
- Always switch off the grinder and disconnect the power plug from the socket before starting to clean or maintain the grinder.



CAUTION!
Risk of tipping and injury.

- Incorrect handling of the grinder can result in injury.
- Position the power cable so that persons cannot become entangled and cause the grinder to fall over.
- Place the grinder on a level and stable surface to prevent it from falling over.

Before initial operation

Functioning and basic settings

The grinder features a removable bean hopper (2) that is locked into place and unlocked by a turnable ring towards its bottom (3). In order to install the bean hopper the ring needs to be placed into “unlock” position. Upon placing the hopper into the grinder neck and turning the ring to “locked” position, the bean hopper will secure safely in place and the bean shutter will open.

The grinder may be used to grind into portafilters (if the portafilter support module is installed (7)) or into the dosing cup (13) or other containers (if the dosing cup support platform is installed (12)). Grinding operation can be turned on and off via the main switch (14) located on the back of the grinder or via the on demand button beneath the portafilter holder on the front of the grinder (9). If the On/Off switch is engaged in position “I”, grinding operation is controlled via the on-demand button (9). On/Off switch position “II” turns on the grinding operation permanently for as long as switch position “II” is engaged.

Validating the grinder and scope of delivery

- ! **Note! Risk of damage!** Take care while opening the grinder packaging with a sharp knife or other pointed objects, otherwise the grinder may be damaged.
-
- Remove the grinder from its packaging.
- Validate that the delivery scope is complete (see p.3).
- Check for damage to the grinder or to its individual parts: if damage is detectable, do not use the grinder and contact your supplier.
- ! **Information:** please note that each grinder is subjected to a function test before delivery and that residues of coffee powder may be present in the grinding chamber.

Before initial operation

Setting up the grinder and inserting the bean hopper

1. Place the grinder on a level and stable surface.
2. Make sure the grinder is switched off (On/Off switch (14) in middle position 0) and connect the grinder to the mains by inserting the mains plug in a properly installed earthed socket.
3. Ensure the spout (6) is pushed up to the maximum and is securely locked in the spout locking mechanism.
4. Insert the drip tray (11) in the corresponding housing recess underneath the spout.
5. Insert the dosing cup holder platform (12) into the recess in the main column. To use a portafilter, follow section "setting up the portafilter".
6. Set the bean hopper locking ring (3) to "unlocked" and place the bean hopper (2) on the bean hopper intake.
7. When placing the bean hopper, make sure to place the nose of the hopper into the corresponding recess of the bean hopper intake on the top of the grinder.
8. Push the bean hopper down into the bean hopper intake and turn the bean hopper locking ring (3) to "locked" position to fix it to the grinder and to open the bean shutter. If the bean hopper cannot be fixed in place, it may not be positioned correctly or the locking ring may be set to the "locked" position (see step 6).

i **Information:** the grinder switches off automatically if the bean hopper is not attached.

Setting up the portafilter

1. Place the grinder on a level and stable surface.
2. Make sure the grinder is switched off (On/Off switch (14) in middle position 0).
3. Use a screwdriver to loosen the portafilter support screws (8) and lower the portafilter support (10) as far as possible.
4. Insert a portafilter into the portafilter holder (7) and push the portafilter support (10) upwards until the portafilter fits exactly between the portafilter support and the portafilter holder.
5. Hold the portafilter support (10) in position and secure it by turning the support adjustment screws (8) clockwise.

Operation

- ! **Note! Risk of overheating!** Exceeding the maximum permissible operating cycle can cause the grinder to overheat.
- Do not exceed the maximum operating cycle and observe recommended pauses when the maximum operating cycle is reached (see chapter “Technical Data”).

i Information

- The grinder applies a thermal overcurrent circuit breaker (15) that interrupts the grinder's circuit in the event of an electrical overload. To start the grinder again after the circuit breaker released, set the On/Off switch (14) to switch position 0 (Off). Then press in the release button (15). You can now switch the grinder on again by setting the On/Off switch to switch position I/II and start up the grinder.
- The grinder also applies a motor protector, which switches off the grinder when the motor becomes too hot. As soon as the motor has cooled down, the grinder can be put into operation again.

- ! **Note! Risk of damage!** The operator has no influence on the thermal overcurrent circuit breaker. If the circuit breaker trips several times, it is essential to consult an authorized service partner as the motor may be damaged.

Filling the hopper with coffee beans

1. Remove the lid (1) from the bean hopper (2).
2. Fill the bean hopper with whole roasted coffee beans. The maximum filling level should be approximately 1 cm below the top edge of the bean hopper while the minimum filling level should be approximately 1 cm above the hopper locking ring (3) to ensure accurate dosing.
3. Reinstall the lid (1) onto the bean hopper (2).
4. If the hopper is in the “unlocked” position, turn the hopper locking ring (3) to the “locked” position to open the bean shutter and allow beans to enter the grinding chamber.

Operation

Switching on the grinder

1. Ensure the grinder is plugged into a properly installed protective contact socket. The grinder is powered and ready to grind as soon as it is plugged in.

Setting and changing the grind size

Turn the grind size adjustment knob (5) to the desired position on the grind size scale (4). Turning the grind size adjustment knob (5) clockwise will yield a finer grind size (position 1 indicates the finest position), whereas turning counterclockwise will yield a coarser grind size (position 5 indicates the coarsest position).

The manufacturer recommends grind size scale position 1 for espresso recipes, positions 2-3 for filter coffee recipes and scale positions 4-5 for recipes requiring coarser grind sizes, e.g. French Press, Percolator, etc.

Information

- Only turn the grind size adjustment knob (5) clockwise for a finer grind size while the grinder is running to prevent damage to the grind size adjustment mechanism.
- To avoid imbalances when adjusting grind size it is recommended to first set a coarser grind size size (about one scale value above the desired value) and only then adjust the grinding size finer to the desired value.

Starting the grinding process

Grinding operation can be turned on and off via the main switch (14) located on the back of the grinder or via the on demand button beneath the portafilter holder on the front of the grinder (9). If the On/Off switch is engaged in position "I", grinding operation is controlled via the on-demand button (9). On/Off switch position "II" turns on the grinding operation permanently for as long as switch position "II" is engaged.

Operation

Changing coffee beans

1. Close the bean shutter by setting the bean hopper locking ring (3) to “unlocked” position and leave the hopper engaged on top of the grinder.
2. Operate the grinding process until the grinder runs empty.
3. Lift the bean hopper (2) upwards from the grinder (the grinder will shut off as soon as the hopper is disengaged from the top of the grinder).
4. Remove all remaining coffee beans from inside of the bean hopper.
5. Remove any excess beans from the bean hopper intake inside of the grinder.
6. Reinstall the bean hopper (2) on the bean hopper intake. When placing the bean hopper, make sure to place the nose of the bean hopper in the corresponding recess of the bean hopper intake and ensure the bean hopper locking ring (3) is set to “unlocked” position while doing so.
7. Refill the bean hopper with new whole roasted coffee beans.
8. Set the bean hopper locking ring (3) into “locked” position to open the bean shutter and to secure the hopper onto the grinder.
9. Grind a few seconds to remove any residues of the previous coffee beans.

Cleaning



CAUTION!

Risk of injury! The grinder may tip over and cause injury when moved.

- Always place the grinder on a stable surface that is safe from tipping over before cleaning.
- Consult for help if the grinder is too heavy or bulky to move alone.



CAUTION!

Risk of injury and danger of short circuit from water entering the grinder!

- Never immerse the grinder in water or other liquids for cleaning
- Never clean the grinder using a water jet or other water propulsion tools
- Ensure that no water or other liquids enter the grinder body casing



Note! Risk of damage!

Improper handling may cause damage to the grinder.

- Do not use any harsh cleaning products or sharp or metallic cleaning objects such as knives, metal scouring pads or similar. These can scratch the surface of the grinder.
- Do not clean the grinder with compressed air (e.g. with a compressed air gun).
- Do not put the drip tray or the lid of the bean container into the dishwasher. The parts are not suitable for dishwashers and may be damaged.
- Do not lift the grinder by the bean hopper; lift only by the casing and always with both hands.

Cleaning

Cleaning the grinder installation surface

1. Switch off the grinder (On/Off switch (14) in the middle position 0) and remove the power plug from the socket.
2. Lift the grinder by its body casing using both hands and place it on a stable and clean surface.
3. Clean the installation surface and the underside of the grinder with a damp cloth and dry the surfaces (surfaces must be dry and free of oil and grease).
4. Place the grinder back on the cleaned surface and ensure steps 1-8 of chapter "setting up the grinder" are followed before resuming grinding operations.

Cleaning the grinder auxiliary components

1. Switch off the grinder (On/Off switch (14) in the middle position 0) and remove the power plug from the socket.
2. Use a brush to clean the following grinder components:
 1. the spout (6),
 1. if necessary, remove the spout by pulling it downwards and clean the grinding house outlet hole as well.
 2. the portafilter holder (7) / the dosing cup holder platform (12).
 3. the portafilter support (10).
 4. the screws (8) to adjusting the portafilter support (left and right).
3. Pull the drip tray (11) upwards and out of the grinder.
4. Use a damp cloth to wipe down the casing and the drip tray as required, but at least once a week.
5. Re-attach all parts removed for cleaning and ensure steps 1-8 of chapter "setting up the grinder" are followed before resuming grinding operations.

Cleaning

Cleaning the bean hopper

1. Close the bean shutter by setting the bean hopper locking ring (3) to “unlocked” position and leave the hopper (2) engaged on top of the grinder.
2. Operate the grinding process until the grinder runs empty.
3. Lift the bean hopper (2) upwards from the grinder (the grinder will shut off as soon as the hopper is disengaged from the top of the grinder).
4. Temporarily transfer the coffee beans from the bean hopper to another container.
5. Use a damp cloth to clean the inside and outside of the bean hopper and allow it to dry.
6. Remove any excess beans from the bean hopper intake inside of the grinder.
7. Reinstall the bean hopper (2) on the bean hopper intake. When placing the bean hopper, make sure to place the nose of the bean hopper in the corresponding recess of the bean hopper intake and ensure the bean hopper locking ring is set to “unlocked” position while doing so.
8. Refill the bean hopper with new whole roasted coffee beans.
9. Set the bean hopper locking ring (3) into “locked” position to open the beanshutter and to secure the hopper on top of the grinder.

Cleaning the grinding mechanism with GRINDZ™

Information

- The manufacturer recommends the use of Urnex GRINDZ™ grinder cleaner.
- More information on how to use GRINDZ™ to clean your grinder is available at www.urnex.com and on YouTube: www.youtube.com/watch?v=7sNRzQqfSzc.
- The grinder requires cleaning every 1-2 weeks for best taste and operation.

Cleaning

Cleaning the grinding mechanism manually

1. The grinder requires cleaning every 1-2 weeks for best taste and operation. Wear gloves while cleaning the grinding mechanism manually.
 2. The grinding discs do not have to be removed from to clean the grinding mechanism.
 3. Switch off the grinder (On/Off switch (14) in the middle position 0) and remove the power plug from the socket.
 4. Remove the bean hopper (2) from the grinder (see chapter "Cleaning the bean hopper", steps 1–3).
 5. Turn the grind size adjustment knob (5) to its coarsest position 5.
 6. Unscrew the two screws on the right and left side of the grind size adjustment knob (5) and pull off the front cover.
 7. Remove the front cover sealing.
 8. Pull out the silicone flapper.
 9. Remove the shear plate that is securing the bean feeder (pre breaker) from the tip of the motor shaft.
 10. Carefully pull off the pre-breaker including rotary grinding disc from the motor shaft.
 11. Use a brush and vacuum cleaner to remove all bean residues from:
 1. The pre-breaker and rotary grinding disc
 2. The grinding house and stationary grinding disc
 3. The outlet hole towards the spout in the grinding house
 12. Re-install the pre-breaker including rotary grinding disc to the motor shaft and ensure no bean residues are between motor shaft and pre-breaker.
 13. Re-install the shear plate in the slot on the tip of the motor shaft.
 14. Replace / re-install the flapper to its slot above the outlet hole in the grinding house.
 15. Re-install the front cover sealing.
 16. Re- install the grinder front cover and tighten the two screws on the right and left side of the adjustment knob (4).
 17. Re-adjust the grinder to your desired grind size.
-

Maintenance

i Information

- Grinding discs should be replaced after grinding ca. 800 kgs of whole roasted coffee beans. The grinding volume until replacement depends on grind size, roast degree, bean type and condition of the grinding discs.
- Wear gloves when changing the grinding discs to avoid injury.
- Recalibrate your grind size after replacing or changing the grinding discs.

Replacing the grinding discs

1. Switch off the grinder (On/Off switch (14) in the middle position 0) and remove the power plug from the socket.
2. Remove the bean hopper (2) from the grinder (see chapter "Cleaning the bean hopper", steps 1–3).
3. Turn the grind size adjustment knob (5) to its coarsest position 5.
4. Unscrew the two screws on the right and left side of the grind size adjustment knob (5) and pull off the front cover.
5. Remove the front cover sealing.
6. Pull out the silicone flapper.
7. Remove the shear plate that is securing the bean feeder (pre breaker) from the tip of the motor shaft.
8. Carefully pull off the pre-breaker including rotary grinding disc from the motor shaft.
9. Use a slot screwdriver to loosen and remove the rotary disc from the pre-breaker and the stationary disc from inside the grinding house.
10. Remove excess ground coffee from both the pre-breaker and grinding house using a hand-held vacuum cleaner or soft bristle brush. Make sure that the surfaces holding the grinding discs are free from coffee particles to allow ideal disc alignment.
11. Place the new rotary disc on the pre breaker and the stationary disc into the grinding house and tighten the disc holding screws with a slot screwdriver.
12. Re-install all grinding components and re-calibrate the grind size to your preferences (see chapter "Cleaning the grinding mechanism manually, steps 12-17).

Maintenance

Information

- The flapper should be replaced if it is porous, deformed or very dirty.

Replacing the flapper

1. Remove the bean hopper (2) from the grinder (see chapter “Cleaning the bean hopper”, steps 1–3).
2. Switch off the grinder (On/Off switch (14) in the middle position 0) and remove the power plug from the socket.
3. Turn the grind size adjustment knob (5) to its coarsest position 5.
4. Unscrew the two screws on the right and left side of the grind size adjustment knob (4) and pull off the front cover.
5. Remove the front cover sealing.
6. Pull out the old silicone flapper.
13. Replace the flapper with a new one to its slot above the outlet hole in the grinding house.
14. Re-install the front cover sealing.
15. Re- install the grinder front cover and tighten the two screws on the right and left side of the adjustment knob (5).

Troubleshooting

Problem	Possible cause	Remedy
The grinder is not grinding	The power plug is not plugged into a socket.	Insert the power plug into a properly installed socket.
	The bean hopper is not installed.	Install the bean hopper (see chapter on "Setting up the grinder and inserting the bean hopper").
	The overcurrent protection switch triggered.	Check whether the release button of the circuit breaker has popped out. Push it back in if necessary. Contact your service partner if the circuit breaker pops out repeatedly.
	The electrical fuse tripped.	Check the electrical fuse. If required, restore the fuse to its original state or replace it. Check whether other loads are connected to this fuse and if so, pull out their plugs. Contact your service partner if the fuse repeatedly trips.
The grinder is making noise but not grinding.	The grinding mechanism is clogged.	Set the grinding degree to coarsest position "5". Start the grinding process. The grinder will clear itself. Then re-set the grinding degree setting to the desired position.
	Coffee has backed up into the grinder due to over-dosing in the portafilter.	Clean the spout. Set the grinding degree to coarsest position "5". Start the grinding process. The grinder will clear itself. Then re-set the grinding degree setting to the desired position.
	The grinding degree is too fine.	Set the grinding degree to coarsest position "5". Start the grinding process. The grinder will clear itself. Then re-set the grinding degree setting to the desired position.
	A foreign object entered into the grinding mechanism.	Clean the grinding mechanism as described in the chapter on "Cleaning" and remove the foreign object in the process. If the foreign object cannot be removed, contact your service partner.

Troubleshooting

Problem	Possible cause	Remedy
The grinder is not grinding fine enough.	The grinding discs reached end of life or need calibration.	Clean or replace the grinding discs or adjust the grinding discs to a finer grind size.
The grinder does not grind continuously / it stops grinding intermittently.	The demand button is damaged.	Contact your service partner..
The bean hopper cannot be installed.	There are coffee beans in the hopper intake.	Remove all coffee beans from the hopper intake.

Technical data

Model	Pinion
Voltage / frequency	120V, 60 Hz, 510 W, 4.7 A 230V, 50 Hz, 450 W, 2.1 A
Grinding output	5-6 g/sec <i>Measured at ca. 250 µm. Output varies according to bean type, roast degree and selected degree of fineness.</i>
Motor idle speed	
▪ 120V, 60 Hz	3.100 rpm
▪ 230V, 50 Hz	3.100 rpm
Max. permitted operating cycle	
▪ 120V, 60 Hz	15 sec. ON / 45 sec. OFF
▪ 230V, 50 Hz	15 sec. ON / 45 sec. OFF
Recommended pause	45 seconds
Max. daily output	30 kg per day
Max. bean hopper filling quantity	600 grams
Dimensions (W x H x D)	150 x 245 x 450 mm
Packaging dimensions (W x H x D)	400 x 350 x 200 mm
Weight	6 kg / 5.5 kg (net)

Disposal

Packaging disposal



Dispose of the packaging by correctly sorting recyclable materials. Dispose of card and cardboard as waste paper and film as recyclable material.

Grinder disposal



Old appliances may not be disposed into commercial/domestic waste. As a consumer, if you can no longer use your grinder, you are required by law to dispose of old equipment separately from commercial/household waste, e.g. at a collection point in your municipality. This ensures professional recycling and avoidance of negative impacts on the environment as much as possible.

Support & Service

Please contact your authorized service partner for PINECONE SWISS products in an event of service or maintenance.

For general inquiries and other customer service please contact:

www.pineconeswiss.com

PINECONE SWISS AG

info@pineconeswiss.com

Bafflestraße 17b

9450 Altstätten SG

Switzerland