

Model Type: Multi 95
HYDRAULIC STEELWORKER

Serial Number:
(Note: last 2 digits represent year of manufacture)

Weight of Machine: 2,430 KG / 5,358 LBS NET

HYDRAULIC STEELWORKER

This Steelworker has been developed to give you, the user, a reliable long service - low maintenance machine tool.

These machines are capable of performing five basic functions, with the facility to add various additional tooling arrangements to complement the fully universal aspects of the Steelworker.

These instructions give general guide lines for the use of the Steelworker, commissioning, operating and maintenance, and should be carefully studied by the installation engineer and operator before the machine is put into operation.

Any assistance regarding the machines, should first be sought from the supplier, or alternatively from the manufacturer:

INDEX

1	<u>SAFETY NOTES FOR STEELWORKERS</u>	1
2	<u>BRIEF SPECIFICATIONS</u>	2
2.1	MEASUREMENTS (Full details, see page 27-28.)	2
2.2	CAPACITIES (Full details, see page 27.)	2
2.3	STANDARD EQUIPMENT SUPPLIED WITH MACHINE	2
3	<u>BRIEF DESCRIPTION OF MACHINE</u>	4
3.1	PUNCHING (For details see pages 8-15)	4
3.2	SHEARING (For details see page 17-18)	4
3.3	ANGLE CUTTING (For details see page 19-20)	4
3.4	SECTION CUTTING (For details see pages 23-24)	4
3.5	NOTCHING (For details see page 25-26)	4
3.6	FURTHER INFORMATION	5
3.7	SAFETY POINTS	6
3.8	OVERLOADING	6
3.9	WARNINGS AND DANGERS	6
3.10	OPERATING MODE SWITCH	7
4	<u>PUNCHING WORK STATION</u>	8
4.1	GENERAL DESCRIPTION	8
4.2	PUNCH TOOLING	9
4.3	PUNCH TOOLING - GENERAL GUIDES	9
4.4	PUNCH AND DIE LUBRICATION	10
4.5	PUNCHING CAPACITY	10
4.6	BAR AND SHEET BENDING FACILITY AT PUNCHING STATION	11
4.7	STANDARD PUNCH TOOLING	12
4.8	STANDARD PUNCH TABLE ASSEMBLY	13
4.9	LARGE HOLE PUNCHING	15
4.10	MATERIAL THICKNESS / MAX. HOLE SIZE	15
4.11	TYPICAL APPLICATIONS	16
5	<u>SHEARING STATION</u>	17
5.1	DESCRIPTION	17
5.2	SHEAR TOOLING - GENERAL GUIDES	17

6	<u>ANGLE CUTTING</u>	19
6.1	DESCRIPTION	19
6.2	ANGLE TOOLING - GENERAL GUIDES	20
6.3	GRINDING OF CHANNEL INSERT BLADES	21
6.4	GRINDING OF JOIST INSERT BLADE	22
7	<u>SECTION CUTTING</u>	23
7.1	DESCRIPTION	23
7.2	SECTION TOOLING - GENERAL GUIDES	24
8	<u>NOTCHING STATION</u>	25
8.1	DESCRIPTION	25
8.2	NOTCHING TOOLING - GENERAL GUIDES	25
8.3	RECTANGULAR NOTCH TOOLING ARRANGEMENT	26
9	<u>FURTHER INFORMATION</u>	27
9.1	CAPACITIES	27
9.2	SPECIFICATION	28
9.3	ADDITIONAL TOOLING	28
9.4	STROKE ADJUSTMENT	29
9.5	HYDRAULIC SYSTEM	30
9.6	CLEANING	30
9.7	REGULAR MAINTENANCE	30
9.8	HYDRAULIC FLUID	31
9.9	OILING LUBRICANT	31
9.10	MACHINE RAM & ARM ADJUSTMENT	31
9.11	PARTS LIST	34
10	<u>CIRCUITS</u>	37
10.1	HYDRAULIC CIRCUIT	37
10.2	ELECTRICAL CIRCUIT	39

11	<u>SPECIAL TOOLING</u>	40
11.1	90° VEE NOTCH TOOLING ARRANGEMENT	40
11.2	WEB PUNCHING ARRANGEMENT FOR 'T' & 'U' SECTIONS	41
11.3	LARGE HOLE PUNCHING	42
11.4	BAR BENDING UNIT	43
11.5	SHEET BENDING UNIT	44
11.6	NOTCH END PUNCHING	45
11.7	SWAN NECK BOLSTER	46
11.8	DOVETAIL QUICKCHANGE ATTACHMENT	47
12	<u>SOUND LEVEL TEST</u>	48
12.1	MAX. SOUND PRESSURE LEVEL	48
13	<u>MANUAL APPENDIX</u>	49
13.1	POSITIONING OF THE PUNCH STRIPPER	49
13.2	MITRING ANGLE 45 DEGREES	50

1 SAFETY NOTES FOR STEELWORKERS

In this manual particular references are made regarding aspects of safety and the notes below are intended as a summary to highlight the main areas for your attention.

The machine should be positioned so that the operator has sufficient room to work having regard for the long lengths of material which may be punched or cropped. Electrical supply should be by overhead supply to avoid possible cable damage.

It should be considered if additional equipment will be required to safely handle long or heavy items being processed.

Any person who will use the machine should be given adequate instruction on the operation and safety aspects of the machine. Extra copies of this manual are available from the manufacturer.

In addition it should be established which persons shall be responsible for the changing and setting of tools and blades and these persons given a more detailed instruction.

machines are supplied complete with various guards and barriers as standard equipment which provide a generally accepted level of guarding when the machine is used for the purpose for which it was designed.

1. The main areas of deviation from design criteria would probably be:
2. The use of materials other than mild steel (45 kg/mm²)
3. The incorrect use of material hold-downs
4. The punching, cropping or notching of small items
(as this would encourage the operator place fingers or hands into danger area).

If at any time additional tooling or equipment is fitted to the machine the question of adequate guarding must be reviewed and the advice of the manufacturer sought if necessary.

Suitably qualified personnel should carry out all maintenance and particular attention must be paid to the correct setting and alignment of punches and dies, blades and other tools.

2 BRIEF SPECIFICATIONS

The machine has been developed to perform five basic functions:
Punching, Flat Bar Shearing, Notching, Angle and Section Cutting.

2.1 MEASUREMENTS (Full details, see page 27-28.)

Length x Width x Height	1,900 x 790 x 1,910 (+90 mm lifting eye)
Die Height from floor	1,039 [mm]
Shear Support from floor	890 [mm]
Angle Support from floor	1,155 [mm]
Section Height from floor	1,250 [mm]
Notch Height from floor	890 [mm]

2.2 CAPACITIES (Full details, see page 27.)

Punching*	27 dia x 25mm or 57 dia x 12mm
Shearing	380 x 20mm or 480 x 15mm
Angle Cutting	150 x 15mm
Section Cutting	50 mm Round, 50mm Square
Notching	13 mm Thickness

(All capacities are based on materials of 45 kg/mm² Tensile Strength.)

*Standard Size Fitment Punch & Die 22 mm (type 9001/9023)

2.3 STANDARD EQUIPMENT SUPPLIED WITH MACHINE

Punch Retaining Ring	2394
Punch Adaptors	9035
Punch & Die (1 set x 22 mm)	9001 - 22 & 9023 - 22
Punch Bolster	4256
Shear Blade (1 set)	2914 & 2389
Angle Blades (1 set)	2401 & 2 off 3931
Section Blades (1 pair)	3197 & 3196
Notch Punch & Dies (1 set)	2386, 3930 & 2 off 3537
Notch Bolster	2362

Tool Kit comprising:

- L220/2006 'C' spanner 95 / 100
- Allen Keys: 4, 5, 6, 8, 10, 12, 14mm
- 9036 Punch Adaptor for 9004
- 81029 Die Adaptor for 9020
- 81031 Punch Adaptor for 9000
- 2908 Punch Location Key
- 24*30 Ring 601-853
- 19mm Open-Ended Spanner
- 12mm star lock washer
- 81102 Die Shoe (for 9023 die)
- 81101 Die Spacer (for 9024 die)
- 81100 Die Spacer (for 9023 die)

3 BRIEF DESCRIPTION OF MACHINE

3.1 PUNCHING (For details see pages 8-15)

The large punch bed area - which is completely removable - is designed to give a very wide range of punching applications; with the available optional tooling - large holes of any shape up to diameter/square as shown in the capacity chart can be punched; or in the overhang position, with the front block removed, flanges of channel or joist can be punched up to diameter/diagonal of 38mm in maximum capacity. A swan neck bolster can be fitted to enable punching in the flange and web of channel, and a dove-tail attachment can be fitted to allow for quick punch changes. Please see page 45-46 for more information on these attachments.

Additional tooling in this versatile work station can provide bending (max. length 500mm), corner notching, tube notching and general die-set work.

3.2 SHEARING (For details see page 17-18)

The shearing unit is fitted with a simple robust hold-down which is adjustable to any thickness of material within the cutting capacity of the machine. A shear feed table with adjustable guides is fitted to allow the accurate feeding of materials. The guide can be adjusted to allow mitre cutting up to 45 degrees for flat bars or to trim the flanges of angle sections previously cut at the angle cutting station.

3.3 ANGLE CUTTING (For details see page 19-20)

This station provides large capacity angle cutting at 90 degrees and lighter angle cutting at 45 degrees. Angles between 45 and 90 degrees can be achieved by first cutting at 90 degrees and then flange trimming to the required angle in the shearing station.

The hold-down supports the material thus ensuring a true cut.

3.4 SECTION CUTTING (For details see pages 23-24)

The machines are fitted as standard with blades for cutting round and square bars. With extra equipment, the machines are able to cut, in this aperture, Channels, Joists and Tee Sections. The blades are retained by simple clamps, allowing easy changes without the need for elaborate setting.

3.5 NOTCHING (For details see page 25-26)

The notching station is fitted as standard with a rectangular unit and notch table with adjustable back stops allowing repetitive positioning. Extra equipment is available for narrow widths or vee notching of angles up to 90 degrees vee; units are also available for bar end shaping applications.

3.6 FURTHER INFORMATION

3.6.1 System Pressure

To check any operational loadings, a pressure gauge can be fitted at the manifold position. The max. system pressure has been set at the works to 250 bar (3,700 P. S. I.) which is below the max. continuous working pressure of the pump, thereby giving increased reliability.

3.6.2 Cleaning

On arrival, all anti-corrosion lacquer should be removed from the machined bright parts with petroleum solvent. When the machine is operational, all visible working parts should be regularly cleaned of foreign matter, thus preventing excessive wear and possible failure.

3.6.3 Lifting

The machine is supplied with a lifting eye, mounted on top of the machine. All lifting and manoeuvring should be carried out using this eye along with a suitably rated chain or sling. The eye can be removed if desired after final siting of the machine and the hole should be blanked off.

DO NOT USE SLINGS UNDER MACHINE!

3.6.4 Installing

Locate the machine on a solid foundation allowing sufficient area all round for easy working and maintenance. The machine may be used free standing, but bolting to the foundation is recommended. With the machine mounted directly on the floor - this gives a comfortable working height.

3.6.5 Electrical Supply

Input wires should arrive at the machine via suitably protected underground supply directly into the electrics box in the base of the machine. As an alternative by overhead supply to the top of the machine and routed inside the top guard and hydraulic pipe trunking to the electrics box. A 30 amp isolating switch, fuse and appropriate cable should be used for mains supply connection. The circuit provides protection against sustained over-load and phase failure. Should the machine cut out during an operation or whilst running, the cause of the problem should be investigated to prevent re-occurrence.

IMPORTANT

Motor rotation MUST be as arrow on motor fan end cover!

This machine will not operate if the motor is running in the wrong direction. It must be stressed however that the motor must not be allowed to run in the wrong direction for more than a few seconds, as this will cause seizure of the pump. To check motor direction start the motor and press the footswitch if machine does not operate reverse two of the incoming 3 phase connections.

3.7 SAFETY POINTS

- All adjustments, setting, change of tooling and maintenance must be carried out by a suitably qualified engineer in accordance with the manufacturers instructions.
- Remove off-cuts, slugs and any other waste from around the machine before leaving the work station.
- The operator should check all tooling is in good condition before operating machine.
- All stations should be checked for obstructions.
- Heavy work should be supported by an adequate work steady.
- The machine should never be left running while unattended.
- When leaving, the machine **MUST** be switched off.
- Always use Kingsland original tooling to be sure of good tool and machine life.

3.8 OVERLOADING

In the event of an accidental overload to the hydraulic circuit, the oil will be diverted direct back to the tank via a relief valve, until the overload condition is removed.

IT MUST BE STRESSED HOWEVER IT IS NOT ADVISABLE TO EXCEED THE CAPACITY OF THE MACHINE USING THE RELIEF VALVE AS A SAFETY VALVE.

3.9 WARNINGS AND DANGERS

Any part of the machine painted YELLOW should be treated as a danger area. Operators should be instructed not to extend any finger or limbs into or beyond the vicinity of the warning labels. Any guards or hold downs removed for maintenance or adjustments **MUST** be replaced before the machine is put back in service.

3.10 OPERATING MODE SWITCH

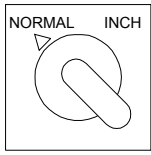

The Operating Mode Switch has two positions - **NORMAL** and **INCH**. With the switch set to **INCH** all work stations are in the slow speed Inching Mode.

3.10.1 Inching Positon

In Inching position the punch (for punch also read shear end) will travel down slowly when footswitch is fully depressed. The punch will remain in any position when foot is removed. Turn switch to **NORMAL** to return punch to top of stroke. All tool setting and adjusting and setting of stroke limit switches should be done in the Inching position.

3.10.2 Normal Operating

With Selector Switch to **NORMAL** the punch will travel down at operating speed when footswitch is fully depressed and will return to top of stroke when foot is completely removed.

The footswitch does however have three “positions” giving the very useful facility that after bringing the punch down by full depression of switch, the punch may be held in any position of the stroke by raising the foot to the mid-position. Remove foot and punch will return to top position.

3.10.3 Punch and Die Alignment

Should be checked before use and **MUST** be checked after punch and die changes have been made.

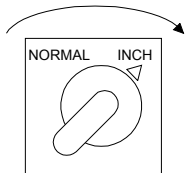

To check alignment switch mode of operation **INCH**, then inch the punch down by fully depressing the footswitch. Care must be taken as the punch approaches the die, if misalignment is apparent remove foot from switch and adjust die bolster.

To align punch and die, release bolster fixing screws, operate the foot switch with care, aligning the bolster containing the die to the punch, the punch will stay in the down position. Centralise the die clearance around the punch, clamp the bolster in position, tighten die retaining screw, check die maintains the central position after clamping. Return punch to top position by switching back to normal position.

4 PUNCHING WORK STATION

4.1 GENERAL DESCRIPTION

The large punch bed area (illustration 1) - is completely removable (illustration 2-3) – and is designed to give a very wide range of punching applications: with the available optional tooling - large holes of any shape up to diameter/square as shown in the capacity chart can be punched; or in the overhang position, with the block removed, flanges of channel or joist can be punched up to diameter/diagonal of 38mm in maximum capacity.

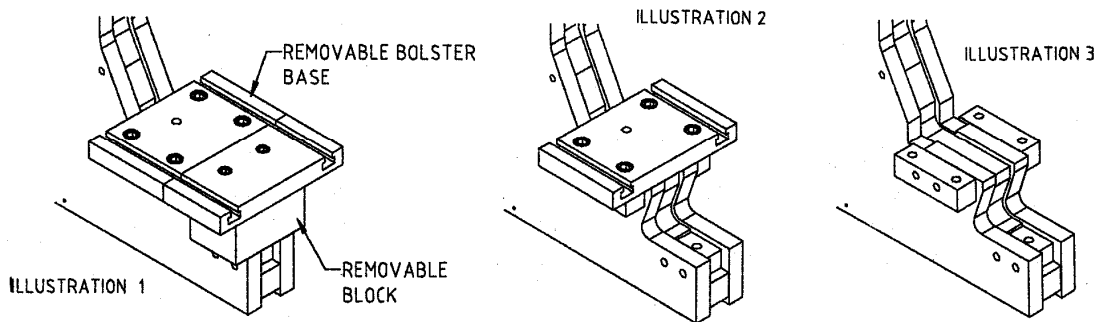

The punch is retained by means of locking ring (part 2557), the punch depending on its size may use one of the two adaptors supplied. The die is retained in the bolster by a set screw, ensure the screw locates correctly on the machined flat on the die when shaped punches and dies are being aligned.

The punch stripper plate must be correctly adjusted allowing sufficient clearance for placing and removal of material, but must NOT restrict the punch stroke, ensure the bottom stroke limit switch is correctly adjusted. Punch holes with sufficient material around the hole so that contact will be made on both sides of the stripper plate. Stripping forces can be severe and unbalanced stripping forces, due to contact on only one side of the stripper, may cause punch breakages.

When using stripper fingers for oversize holes or irregular shapes, position and adjust fingers equally so as to avoid unbalanced stripping loads.

Additional tooling in this versatile work station can provide bar and plate bending, corner notching, tube notching and general die-set work.

WHEN ORDERING REPLACEMENT PUNCHES AND DIES, ALWAYS QUOTE - MODEL, TYPE AND SERIAL NUMBER OF MACHINE.

4.2 PUNCH TOOLING

The Punch and Die should be checked for alignment, prior to punching any material. Standard size fitment 22mm, unless specifically ordered otherwise.

4.2.1 Tooling Changes

Punch: To change punch, unscrew locking ring using 'C' Spanner from tool kit, replace punch and retighten locking ring. Adaptors are supplied to suit various punch head sizes.

Die: To change die, slacken set screw in side of bolster, remove die and replace with new die, retighten set screw.

After replacing punches and dies, it is important that they are correctly aligned. See page 7 for alignment procedure. Extra care must be taken when fitting square or shaped punches that they are correctly aligned before operating the machine.

4.3 PUNCH TOOLING - GENERAL GUIDES

1. The punch stripper plate must be adjusted correctly with sufficient clearance to allow positioning and removal of the material being punched.
2. Punch holes with sufficient material around the hole so that contact is made with both sides of the stripper plate. Stripping forces can be severe. Unbalanced stripping forces may cause punch breakage.
3. Liberal oiling of the punch will considerably lengthen the life of the punch and die and also help reduce the stripping forces. Automatic lubrication units are available, for more information please contact
4. The quality of the hole /or blank/ is an immediate indication of the condition of the punch and die.
5. Do not punch material thicker than the punch diameter, this overloads the punch and can result in breakage.
6. Punch full and complete holes, do not punch partial holes /unless tooling is specifically designed to do so.
7. When punching small items (i.e. small pieces of plate, bar etc) these items MUST be placed and extracted with suitable handling aids, extra guarding may be required to ensure operator safety.
8. Stay within the rated capacity of the machine.

4.4 PUNCH AND DIE LUBRICATION

It is recommended that one of the following oils is applied by brush or spray to the punch and die or both sides of the material being punched.

SHELL	- GARIA 927
B. P.	- SERVORA 68
CASTROL	- ILOBROACH 219
DUCKHAMS	- ADFORNOL EP7

When punching aluminium it is recommended that Parafin is used as a lubricant.

Die clearance: It is normal practice to aim for a clearance of 10% of material thickness.

Whether clearance is added to the size of the die or deducted from the size of the punch, depends on the nature of the work. When holes of a given size are required the punch is made to size and the die is made larger. Conversely, when blanks of a given size are required the die is made to size and the punch smaller.

Special clearance dies for thin sheet and plate punching, or size dies and special clearance punches can be supplied to order.

4.5 PUNCHING CAPACITY

To keep within the rated capacity of the machine, the following example is intended as a guide for calculating punching force.

$$\begin{aligned} \text{Punching force} &= \text{shear area} \times \text{tensile strength of material} \\ \text{where shear area} &= \text{circumference of punch} \times \text{thickness of material} \end{aligned}$$

Example

A 20 mm hole is required in a piece of 12mm thick mild steel plate at 45 kg/mm² Tensile Strength.

$$\text{Punching force} = \frac{\text{Shear area} \times \text{tensile strength}}{1000}$$

$$\text{Shear Area} = \text{Circumference of punch} \times \text{thickness of material}$$

$$\text{Tensile Strength} = 45 \text{ kg /mm}^2 \text{ or } 450 \text{ N/mm}^2$$

$$0.0098 = \text{Constant to convert kg/mm}^2 \text{ to KN}$$

$$\text{Therefore: } \frac{20 \times 3.142 \times 12 \times 45}{1000} = 33.9 \text{ Tons}$$

4.6 BAR AND SHEET BENDING FACILITY AT PUNCHING STATION

Press Brake type tooling is available for fitting at the Punching Station giving press brake capacity of 250mm x 20mm (bar) up to max. width 500mm x 3mm (Sheet).

IMPORTANT NOTICE - HEALTH & SAFETY AT WORK ACT, SECTION 6

Bending tools must not be fitted to this machine until adequate safety measures have been implemented. It is normally permitted to use the bending tools without additional fixed guarding provided the following steps have been taken:

1. The clearance between the top tool and the work piece is kept to a minimum and must not exceed 6mm at any time. For information on setting the stroke please refer to page 29.
2. The bending tool is set by a skilled and competent person.

IMPORTANT NOTICE: NEVER USE THE MACHINE TO MAXIMUM CAPACITY WHEN PUNCHING IN THE OVERHANG POSITION (SEE DRAWING BELOW). WHEN PUNCHING MAXIMUM CAPACITY THE BOLSTER MUST BE TURNED AND THE BACK SECURING BOLT MUST BE USED.

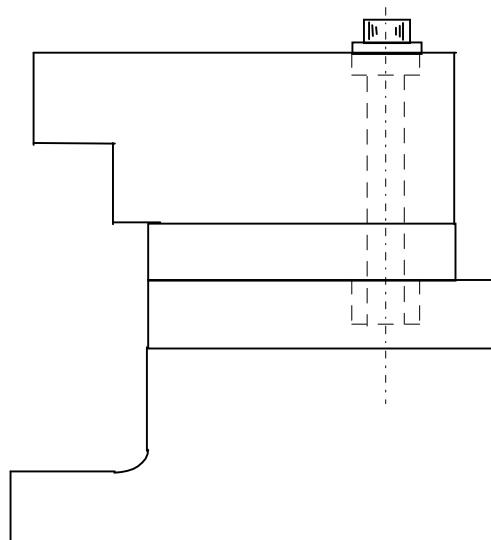

4.7 STANDARD PUNCH TOOLING

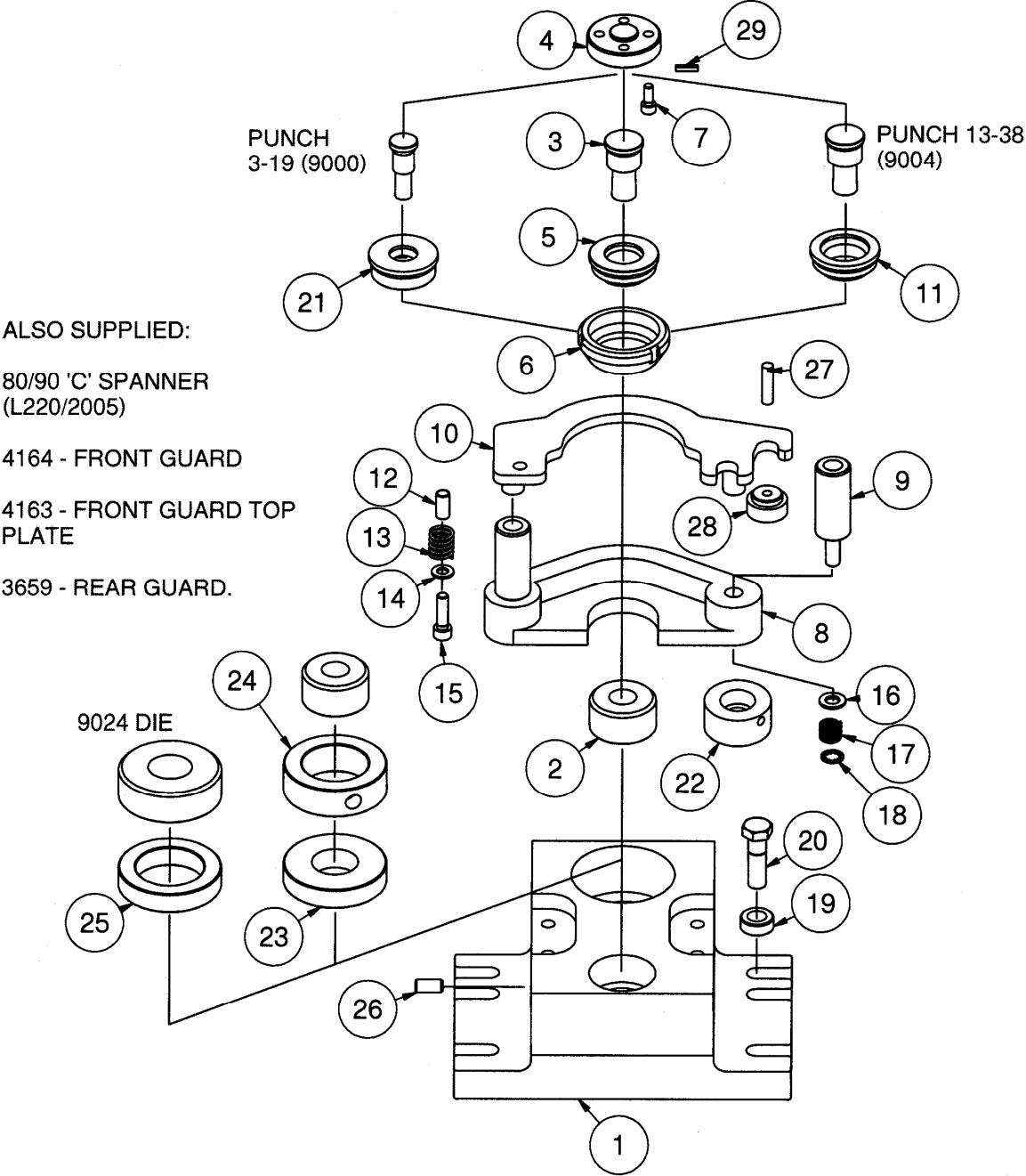

MULTI95 HYDRAULIC STEELWORKER

In the following table you can find a list of the standard punch tooling of the Multi 95. It includes equipment supplied with the machine. The standard punch tooling includes 22mm punch (9001) and die (9023). Other punches and dies are available on request.

No.	Part No.	Description	No. off
1	4256	Bolster	1
2	9023	Die	1
3	9001	Punch	1
4	2393	Pressure Plate	1
5	9035	Adaptor for punch up to 30mm	1
6	2394	Retaining Ring	1
7	K605/5343	M12 x 25 Cap Screws	4
8	2259	Stripper Head	1
9	2407	Stripper Pillar	2
10	2257	Stripper Top Plate	1
11	9036	Adaptor for Punching up to 38mm	1
12	2887	Spacer	1
13	K705/3006	Spring	1
14	K605/7310	Washer 10mm	1
15	K605/5336	M10 x 35 Cap Screw	1
16	K605/7312	12mm Washer	2
17	K605/3009	Spring	2
18	K605/7905	12mm Starlock Washer	2
19	2999	Bolster Washer	6
20	K605/37521	M16 x 55 HT Bolt	6
21	81031	Adaptor for punch up to 19mm	1
22	81029	Adaptor for die up to 20mm	1
23	81100	Die spacer for 9023 die	1
24	81101	Die shoe for 9023 die	1
25	81102	Die spacer for 9024 die	1
26	K605/5613	Die locking screw	1
27	K605/0020	Stud	1
28	K605/1005	Knurled nut	1
29	L805/2700	Punch location key	1

4.8 STANDARD PUNCH TABLE ASSEMBLY

1	4258	PUNCH TABLE	1
2	4258	PUNCH TABLE EXTENSION	1
3	87078	PUNCH TABLE BEAM	1
4	87060	TABLE GUIDE BLOCK	2
5	87061	GUIDE BLOCK RETAINING PLT	2
6	87063	GUIDE BLOCK PAD	2
7	87059	MATERIAL STOP	1
8	87096	MATERIAL STOP EXTENDING BAR	1
9	87081	FRONT TABLE FIXING PLATE	2
10	K605/3530	M12x25 CSK SOCKET SCREW	4
11	K605/5344	M12x30 CAP HEAD SCREW	4
12	K605/7512	12mm SPRING WASHER	4
13	K605/7312	12mm WASHER	4
14	K705/1908	HB K1PP HANDLE	3
15	K605/7308	8mm WASHER	7
16	K605/5328	HBx50 CAP HEAD SCREW	4
17	K605/3490	HBx20 CSK SOCKET SCREW	1

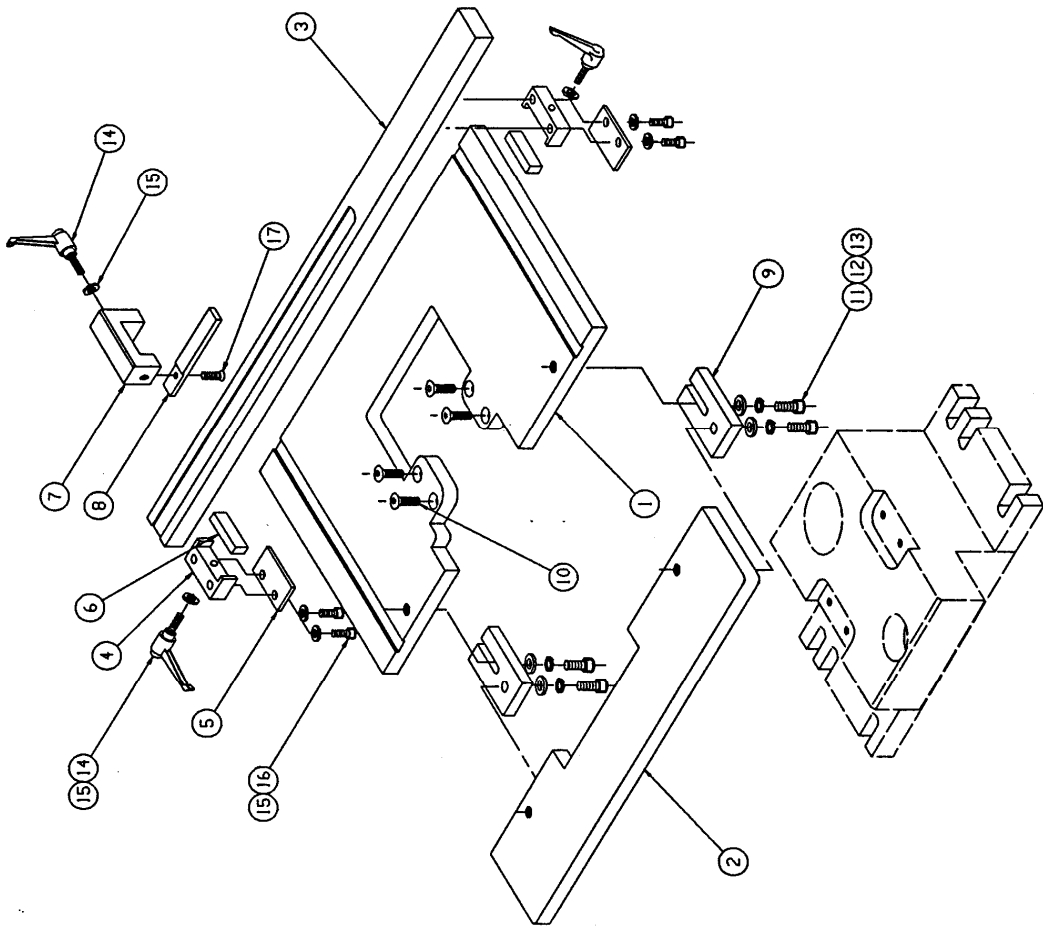

4.9 LARGE HOLE PUNCHING

Extra equipment available for punching up to 110mm or 160mm dia.

- This unit comprises:
- Special ram pressure plate
 - Adaptors
 - Retaining Ring
 - Bolster with die holder plates
 - Large hole stripper head

Punch and die sets available for these units -
 For hole sizes up to - 57mm dia (110 & 160 unit)
 85mm dia (110 & 160 unit)
 110mm dia (110 & 160 unit)
 135mm dia (160 unit only)
 160mm dia (160 unit only)

4.10 MATERIAL THICKNESS / MAX. HOLE SIZE

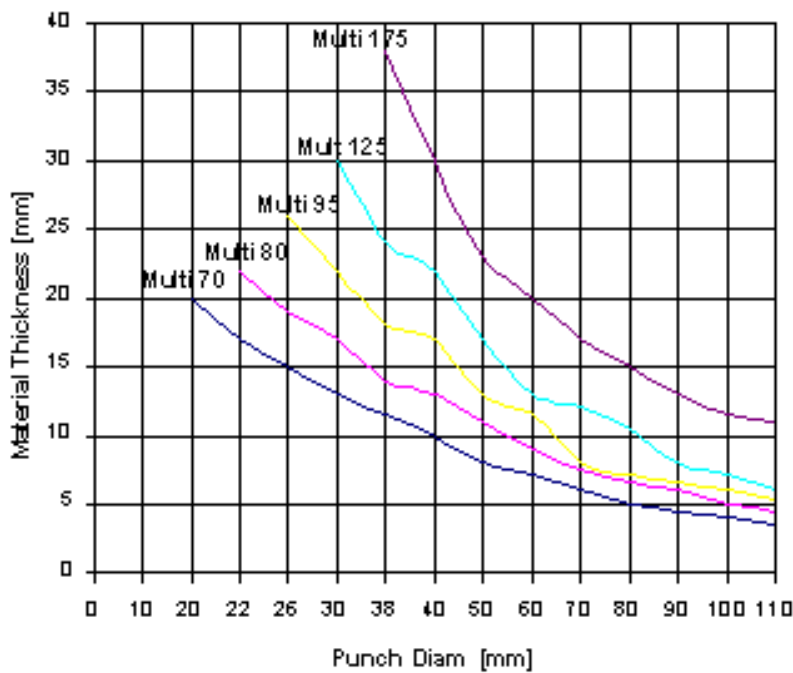

(all Capacities based on Material Strength of 45 kg/mm²)

Please Note:

DANGEROUS PRACTICE:
 DO NOT ATTEMPT TO PUNCH MATERIAL
 THICKER THAN THE PUNCH DIAMETER!

4.11 TYPICAL APPLICATIONS

(achieved with optional tooling at punch station)

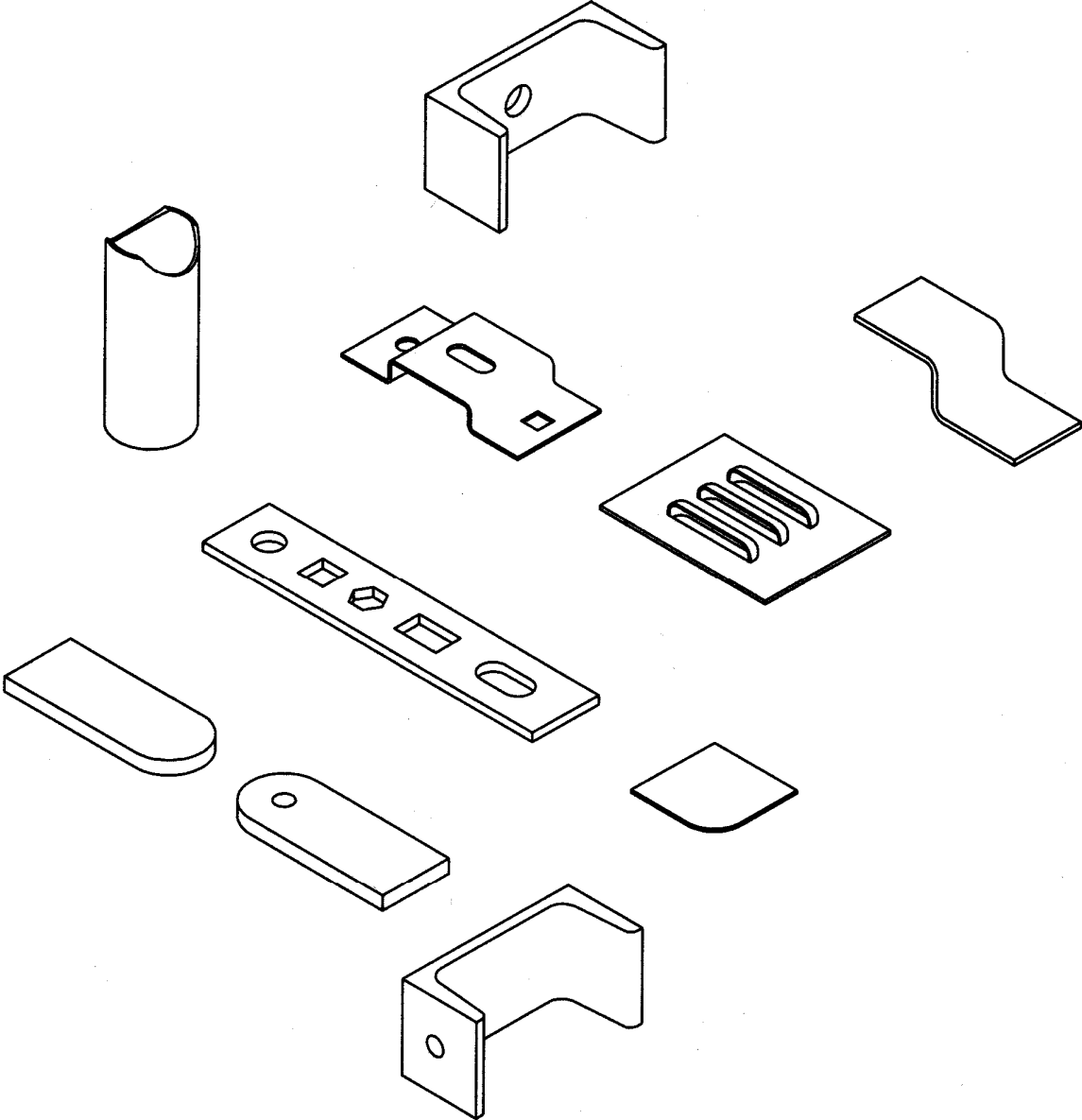

5 SHEARING STATION

5.1 DESCRIPTION

The shearing unit is fitted with a simple robust hold-down which is adjustable to any thickness of material within the cutting capacity of the machine. A shear feed table with adjustable guides is fitted to allow the accurate feeding of materials. The guide can be adjusted to allow mitre cutting up to 45 degrees for flat bars or to trim the flanges of angle sections previously cut at the angle cutting station.

The standard shear blades as fitted; permit the bottom blade to be turned four times giving 4 new cutting edges, whilst the top blade must be ground to sharpen the cutting edge. These blades give minimum distortion from full capacity down to 2mm thickness.

Parallel top blades (Pt. No.2390) can be supplied to order for cutting narrow bar widths or where flatness of cut is not so important. These blades can be changed 2 times each.

When the shear blades require sharpening, grind only on the cutting faces - max. regrinding 0.80mm, after grinding the blades must be adjusted to a clearance of 0.08 mm. Adjusting screws have been provided to reset the shear blades, the adjusting screws are positioned around blade fixing screws, accessible when shear table has been removed. Even clearance between top and bottom blades is important along the entire blade length and care should be taken to ensure that the bottom blade is in a vertical plane, parallel to top blade.

**WHEN ORDERING SPARE BLADES, ALWAYS QUOTE -
MODEL, TYPE AND SERIAL NUMBER OF MACHINE.
FOR MORE ADVICE CALL OUR TOOLING DEPARTMENT ON**

5.2 SHEAR TOOLING - GENERAL GUIDES

1. The quality of the cut is an immediate indication of the condition of the blades.
2. Ensure hold-down is always set for relevant thickness of material being sheared.
DO NOT allow ends of bars to be fed beyond the hold down, because bar would tend to twist between blades and cause machine frame distortion.
3. Always feed material between blades from the hold down side.
4. Keep the blade area clean. Do not allow 'build up' of mill scale.
5. Stay within the rated capacity of the machine.

MULTI95 HYDRAULIC STEELWORKER

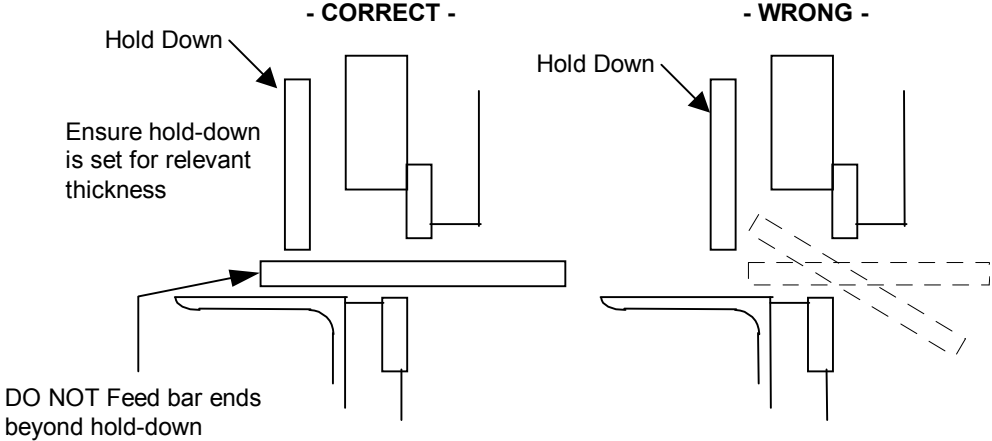

SHEAR BLADES AND FIXING MATERIALS

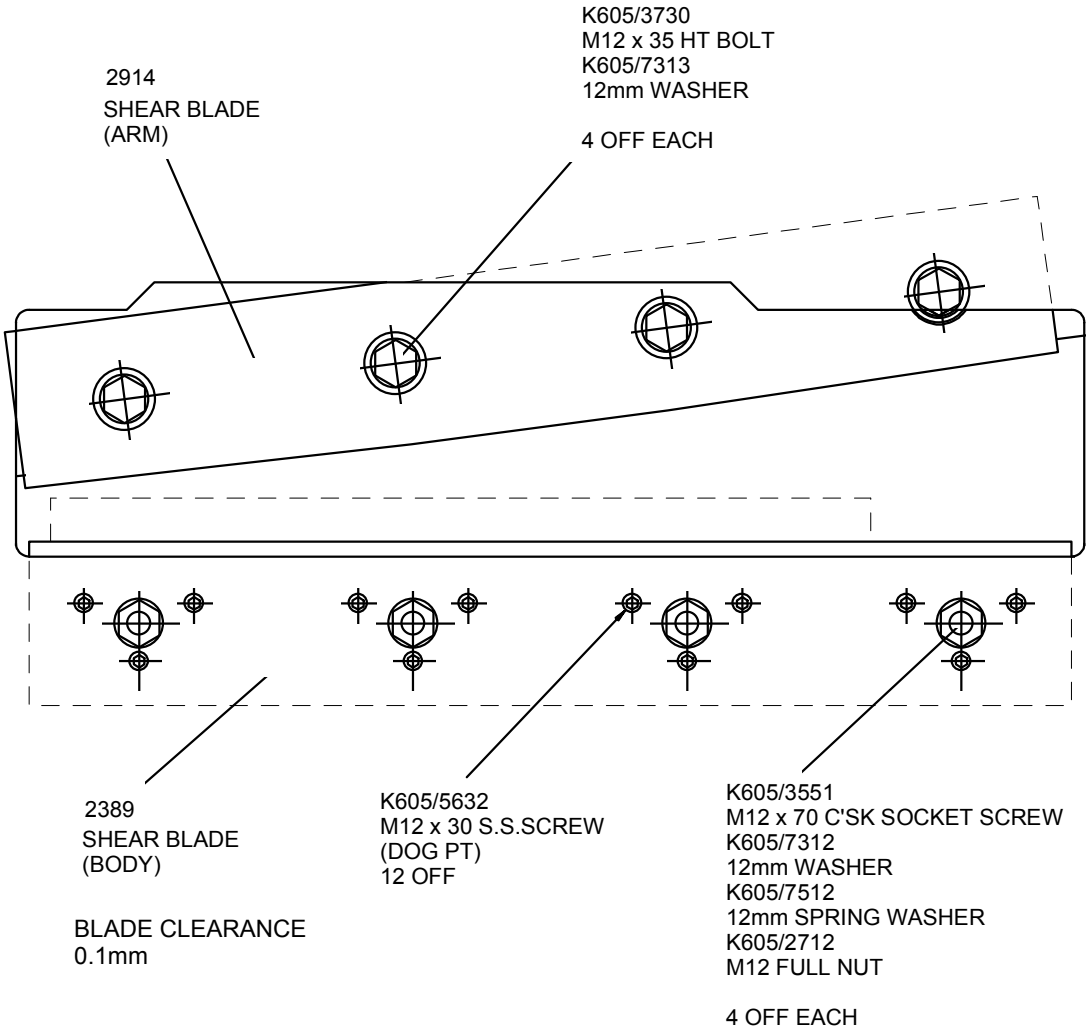

6 ANGLE CUTTING

6.1 DESCRIPTION

This working station provides large capacity angle cutting at 90 degrees and lighter angle cutting at 45 degrees.

To cut angle section, place the material through the hold down into the cutting area, adjust the support screw to the material but leave sufficient clearance to enable the section to be fed on for progressive cutting.

To mitre cut at 45 degrees:

firstly cut the angles to length allowing approx. 12mm oversize for end trimming.

1. Place the first end into the blade using the higher support position, trim approx. 6mm off the end of the section whilst maintaining 45 degrees to vertical position.
2. Place the other end into the blade using the left hand support position, trim section to length whilst maintaining 45 degrees to face of machine position.

To achieve other angles of cut between 45 degrees and 90 degrees, first cut the angle section to length and then trim the flange to required angle in the shear station.

The slot in the shear hold down allows angle sections to be positioned for left hand or right hand trimming, ensure hold down is set for relevant thickness.

Each cutting blade has four cutting edges and is retained by simple fixing screws.

DO NOT sharpen these blades, after turning four times replace with new blades.

**WHEN ORDERING REPLACEMENT BLADES, ALWAYS QUOTE -
MODEL, TYPE AND SERIAL NUMBER OF MACHINE.
FOR MORE ADVICE CALL OUR TOOLING DEPARTMENT ON**

6.2 ANGLE TOOLING - GENERAL GUIDES

1. The quality of cut is an immediate indication of the condition of the blades.
Keep sharp, keen cutting edges.
2. Ensure support screw is set for relevant thickness of material being cut.
3. Always feed material between blades from hold down side.
4. Keep cutting aperture clean, small slivers, short cuts and any other pieces should be removed from the blade area. DO NOT allow mill scale to 'build up' in the blade area.
5. Stay within the rated capacity of the machine.

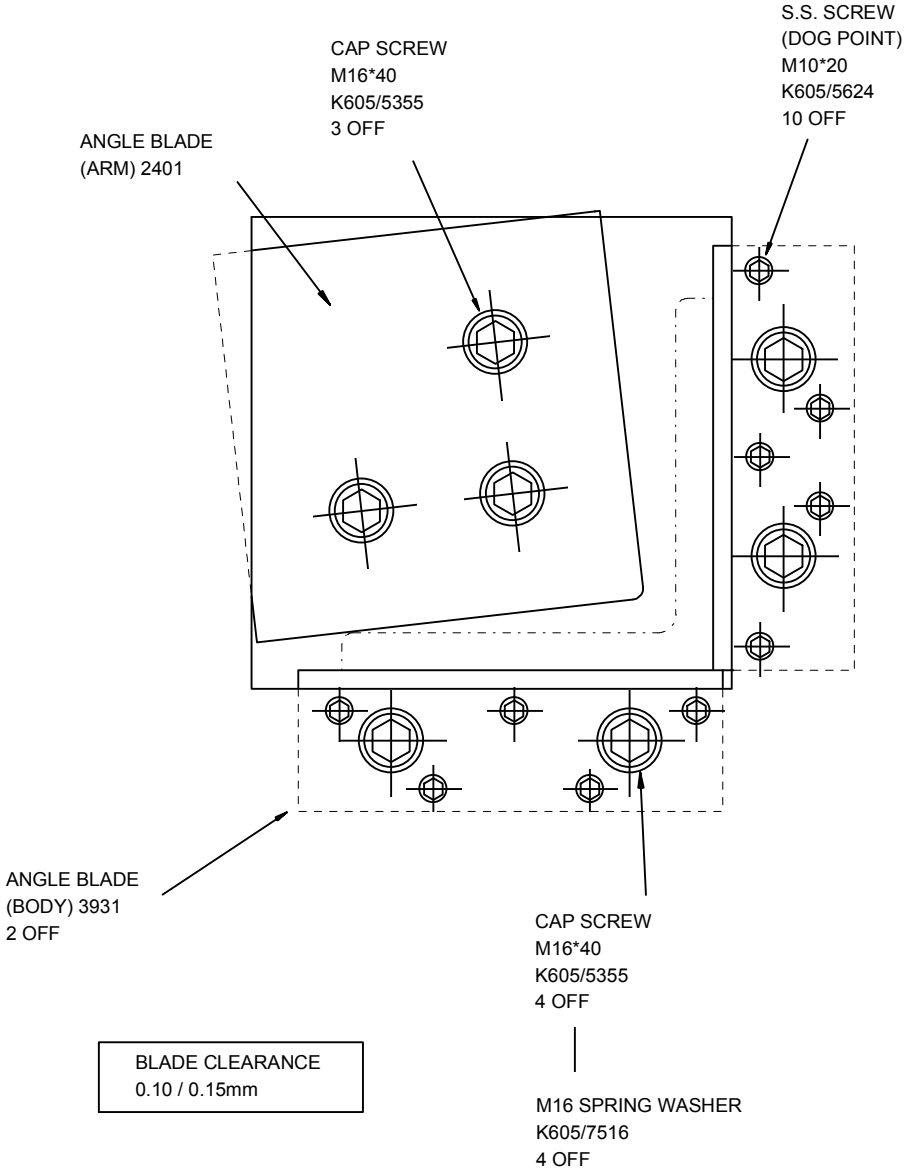

6.3 GRINDING OF CHANNEL INSERT BLADES

Body Blade

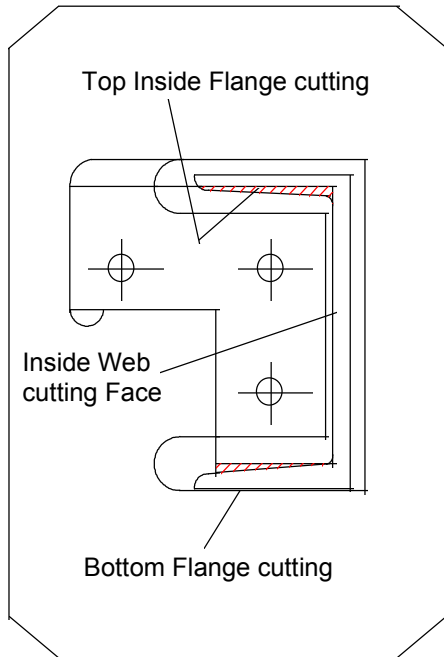

Fit blade to carrier, retain position with three screws, ensure blade is seating on both faces, see sketch. Mount a sample of channel, with a cleanly cut end, on to the blade with the bottom flange in line with bottom cutting face and the inside of the web square and in line with the inside web cutting face, as shown in sketch.

Having mounted channel correctly, scribe round inside of channel flanges.

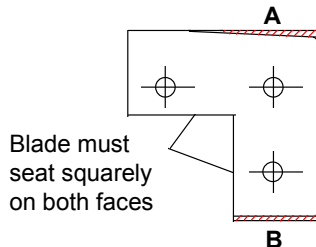

- Remove blade from carrier.
- With 'mark out' A continue inner flange line as shown.
- With 'mark out' B continue line from radius square to cutting face. Allow a small clearance when grinding to permit easy passage of channel.

Grinding

Grind insert blades to lines scribed, shown shaded in sketch.

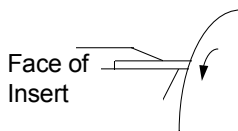

When hand grinding, if using face of grinding wheel, ensure angle between face of insert and cutting face does not exceed 90 degrees.

6.4 GRINDING OF JOIST INSERT BLADE

Body Blade

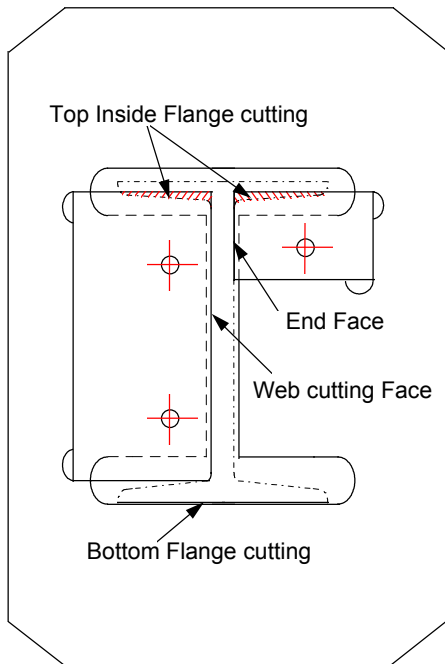

Fit blades to carrier, retain positions with fixing screws, ensure blades are seating correctly. Mount a sample of joist, with a cleanly cut end, on to the blade with the bottom flange in line with **BOTTOM CUTTING FACE** and the web square and in line with **WEB CUTTING FACE**, as shown in sketch.

Having mounted joist correctly, scribe round inside of joist flanges.

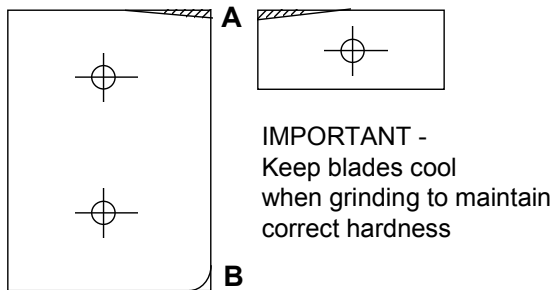

- Remove blades from carrier.
- With 'mark out' A continue inner flange line of required section.
- With 'mark out' B radius to suit that of sample joist.
- The **END FACE** may require clearance to permit easy passage of joist for heavy or light sections, when blades are in cutting position.

Grinding

Grind insert blades to lines scribed, shown shaded in sketch.

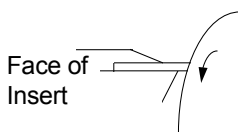

When hand grinding, if using face of grinding wheel, ensure angle between face of insert and cutting face does not exceed 90 degrees.

7 SECTION CUTTING

7.1 DESCRIPTION

A variety of sections can be cropped at this aperture - round and square sections, unequal angle, channel, joist etc.

Blades for round and square section cropping are fitted as standard equipment and have apertures of varying sizes. The smallest aperture should be chosen, which will accept the material, thus ensuring a complete and well supported cut.

To change the blades, the material support must be removed. Release the four screws securing the blade clamps, remove blade clamps then withdraw the blades.

It will be noticed that the arm blade is smaller than the body blade.

This safeguards incorrect assembly when inserted carrier blades are used. Also notice the safety peg, there is a safety slot in the arm blade to prevent incorrect positioning.

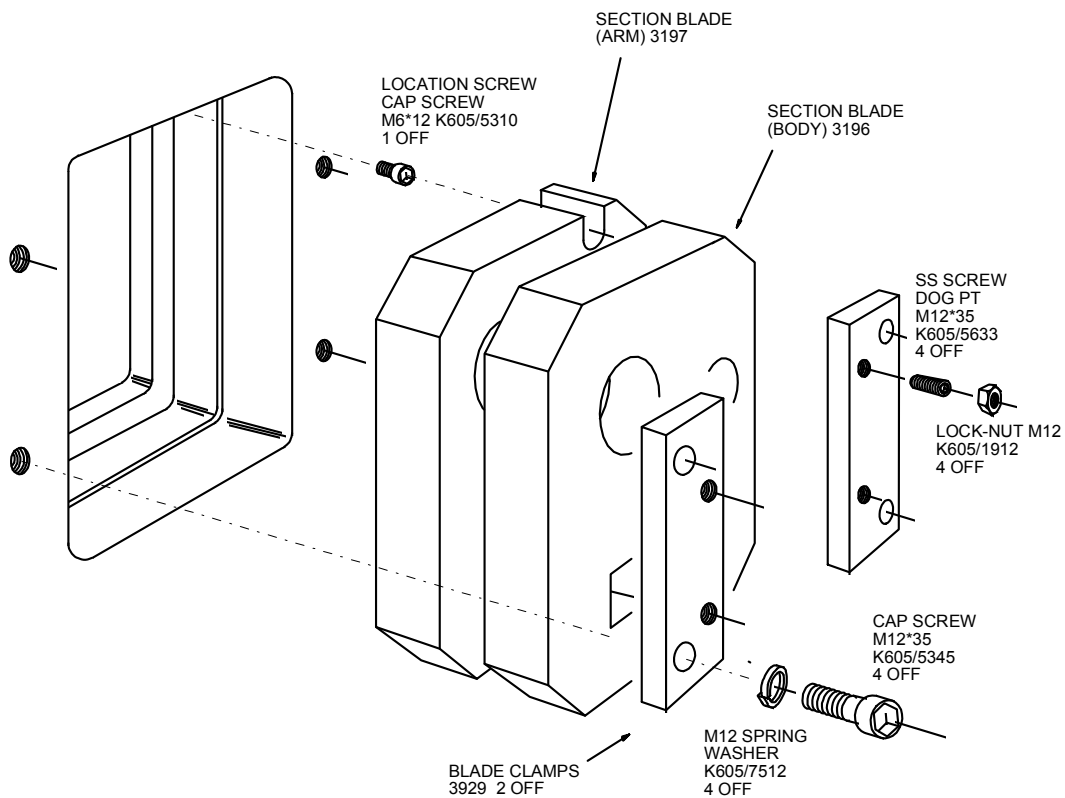

To set blade clearance:

Ensure arm blade is properly seated in shear arm.

Position body blade in frame firmly pushed against arm blade.

Secure blade clamp to frame.

Tighten the four SS screws, then release each one 0.2 of a turn.

Tighten locknut whilst holding the SS screw with alan key.

IMPORTANT:

- ⇒ Never remove screw fitted as safety peg in the arm blade milled recess.
- ⇒ In the case of worn solid blades, new blades must be fitted.
DO NOT attempt to regrind faces; this makes blades undersize for secure fitting.
- ⇒ In the case of worn insert blades, new inserts can be supplied for grinding to worn sample.
- ⇒ When fitting new blades reverse the removal procedure.
- ⇒ To cut sections place the material through the hold down into the cutting area, adjust the hold down screw (if fitted) to achieve square cut.

**WHEN ORDERING SPARE BLADES, ALWAYS QUOTE-
MODEL, TYPE AND SERIAL NUMBER OF MACHINE.
FOR MORE ADVICE CALL OUR TOOLING DEPARTMENT ON**

7.2 SECTION TOOLING - GENERAL GUIDES

1. The quality of the cut is an immediate indication of the condition of the blades.
Keep sharp, keen cutting edges.
2. Ensure bar sizes are used in smallest aperture that will accept them, ensuring well supported cut.
3. Always feed material between blades from hold down side.
4. Keep cutting aperture clean, small slivers, short ends and any other pieces should be removed from the blade area. DO NOT allow mill scale to 'build up' in the blade area.
5. Stay within the rated capacity of the machine.

8 NOTCHING STATION

8.1 DESCRIPTION

The notching station has a rectangular punch as standard fitting and is supplied with a notch table complete with adjustable side and back stops which allow repetitive material positioning.

Vee notch tooling can be fitted at this work station, or alternatively units can be supplied for narrow widths of rectangular or vee shapes; units also available for bar end shaping.

A particular feature of this work station, provides for some punch end units to be fitted - i.e. small punching applications up to 40T pressure. (Details on request)

When notch punch requires sharpening, grind side and front faces of punch only.
The dies have four cutting edges and should be turned to present new cutting edge.

To adjust dies after punch grinding:

1. Slacken bolster fixing screws and position locking screws.
2. Move bolster into new side and front position on punch;
one side of bolster is adjustable on the die.
3. Clearances between punch and die faces should be maintained as follows:
.....at sides of punch 0.1mm
.....at front of punch 0.3mm
Adjust bolster on the two faces accordingly and retighten fixing screws -
check clearances.
4. Release adjustable die blade fixing screws and adjust blade to punch,
tighten fixing screws and check clearance.
5. Ensure fixing screws are tight and that the positioning locking screws have been reset.

**WHEN ORDERING SPARE PUNCHES AND DIES, ALWAYS QUOTE -
MODEL, TYPE AND SERIAL NUMBER OF MACHINE.
FOR MORE ADVICE CALL OUR TOOLING DEPARTMENT ON**

8.2 NOTCHING TOOLING - GENERAL GUIDES

1. The quality of cut is an immediate indication of the condition of the tooling.
Keep sharp, keen cutting edges.
2. Check that the notched blank ejects after notching operation, thus avoiding
any 'build up' of slugs.
3. Stay within the rated capacity of the machine.

8.3 RECTANGULAR NOTCH TOOLING ARRANGEMENT

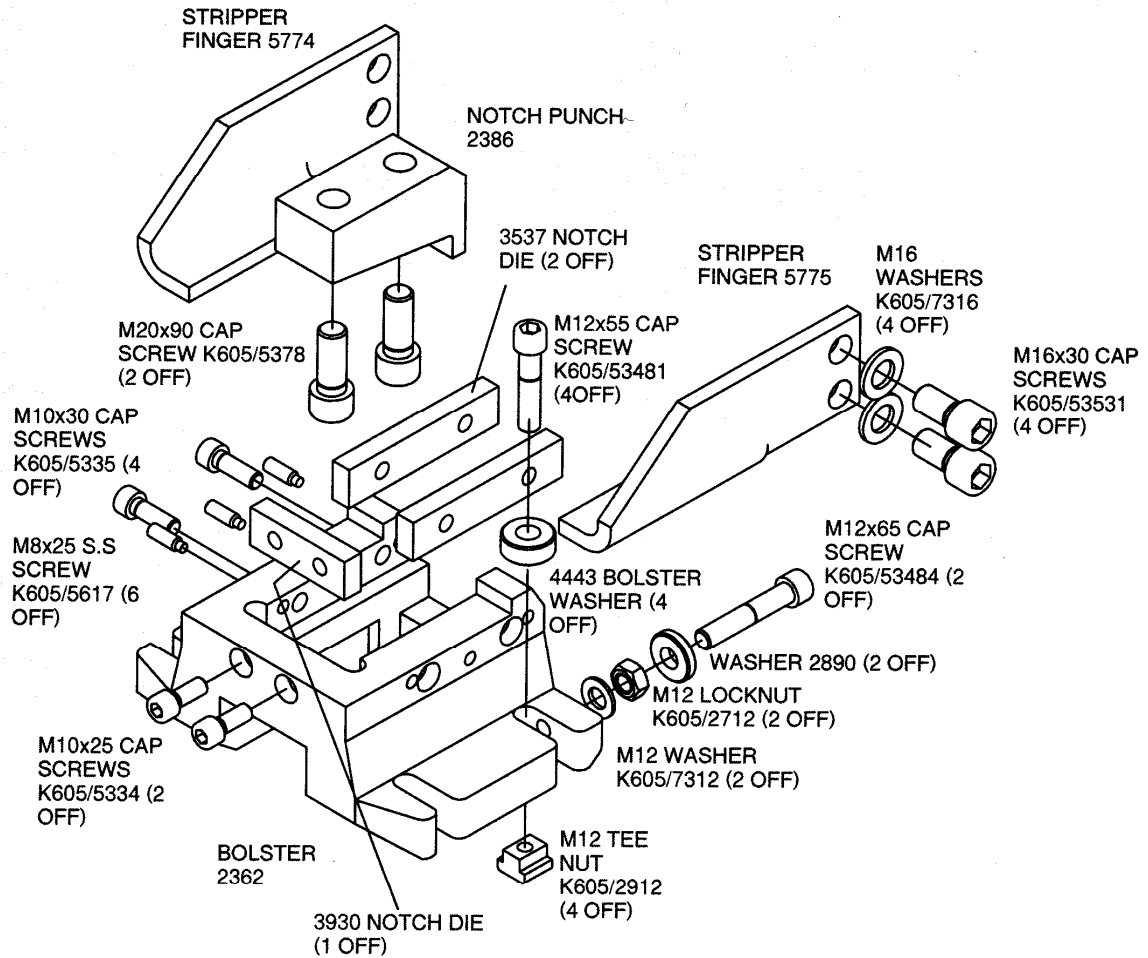

ALSO SUPPLIED WITH:

- NOTCH TABLE - 2403
- TABLE MOUNTING BLOCKS - 2282 (2 OFF)
- M12x30 CSK SCREWS - K605/3543 (2 OFF)
- NOTCH GUIDES - 2626 (3 OFF)
- M12x35 GUIDE FIXING BOLTS - K605/6130 (3 OFF)
- M12 KIPP HANDLES - K705/2010 (3 OFF)

9 FURTHER INFORMATION

9.1 CAPACITIES – MULTI 95

<u>9.1.1 Punching</u>	<u>Metric (mm)</u>	<u>Imperial (inches)</u>
Max. Capacities	27 x 25	1 1/16 x 1
Dia. x Thickness	57 x 12	2 1/4 x 1/2
Max. Stroke Length	80	3 1/8
Speed - 20mm travel	34 full cycles/min	
Throat Depth Standard	355	14
Throat Depth Multi-D Model	625	25 (Deep Throat option)
Largest Hole	160	6.3/8 (optional equip.)
Working Height	1,039	40 5/16
Max. Section Flange Punch	305	12

9.1.2 Shearing

Flat Bar Max. Thickness	380 x 20	15 x 3/4
Alternative Max. Width	480 x 15	18.3/4 x 5/8
Blade Length	483	18.3/4
Angle Flange Trim	120 x 15	5 x 5/8
Working Height	890	35

9.1.3 Angle Cutting

At 90° with non deforming multi-edged blades	150 x 15	6 x 5/8
At 45° Mitre	80 x 10	3 x 3/8
Working Height	1,155	45.1/2

9.1.4 Section Cutting

Round/Square Bar	50	2
Channel Beam	160 x 90	6 x 3.1/2
Tee	100 x 12	4 x 1/2

9.1.5 Notching

Material Thickness	13	1/2
Width	52	2
Depth: Vee-Rect.	70 – 100	2.3/4 – 4
Angle Flange	100 x 13	4 x 1/2
Working Height	890	35

9.2 SPECIFICATION

	<u>Metric</u>	<u>Imperial</u>
Motor	7,5 Kw	10 Hp
Nett Weight	2,430 Kg	5.358 lbs
Gross Weight	2,640 Kg	5.821 lbs
Machine Dims.	190 x 79 x 191cm	75 x 31 x 75"
Packed Dims.	205 x 94 x 209cm	81 x 37 x 82"

9.3 ADDITIONAL TOOLING**Bending**

Max. Bar Size	250 x 20 or	10 x 3/4
Sheet	500 x 3	24 x 1/4

Punching at Notch Station

Max. Capacity	38 x 10	1.1/2 x 3/8
Throat Depth	125	5

Corner Notch

Max.	250 sq x 6	10 sq x 1/4
------	------------	-------------

Tube Notch

Max. Diam. O.D.	108	4.1/4
-----------------	-----	-------

9.4 STROKE ADJUSTMENT

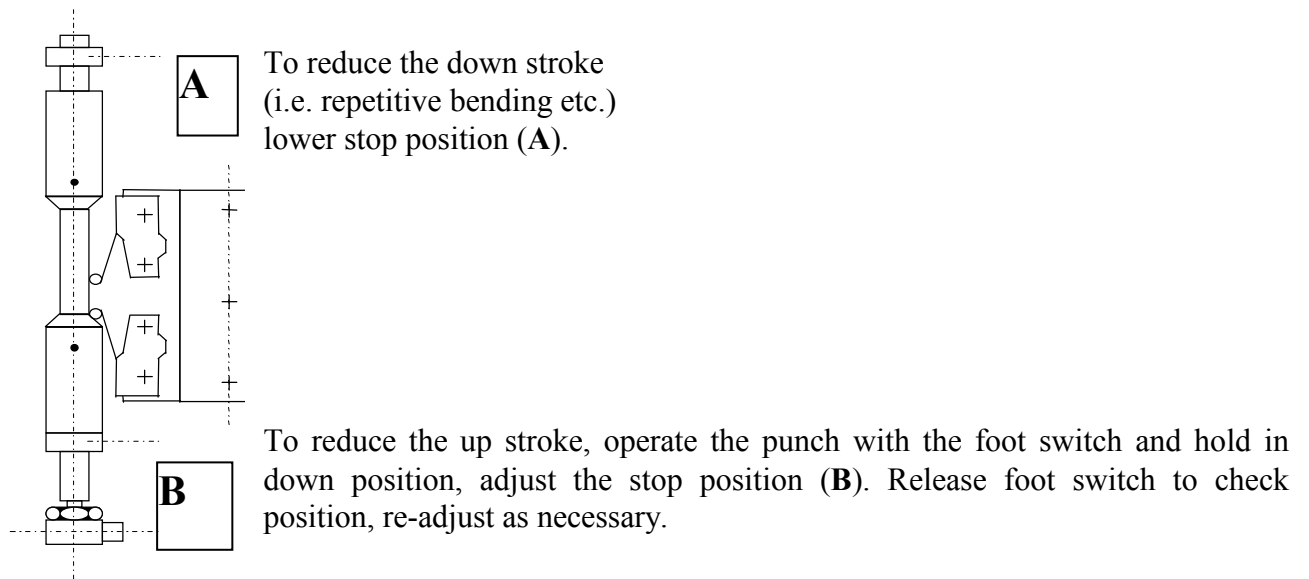

ALSO AVAILABLE IS A FINE STROKE ADJUSTMENT. IDEAL FOR BENDING APPLICATIONS.

Note: Adjustments to stroke limiters can be arranged by switching to the INCH mode of operation; the punch position and/or shear-cutting position is then set by operating the foot pedal to achieve position required. Adjust appropriate stop position, tighten stop screw; then re-check setting under normal inch position.

9.5 HYDRAULIC SYSTEM

A 7.5 KW Motor drives a hydraulic pump, which through control valves feed the power cylinders at each end of the machine. The punch cylinder directly loads the punching unit whereas the shear cylinder is connected to a pivoted arm.

Hydraulic Oil - refer to „the recommended oils“ label. The oil filler/breather is positioned on the tank accessible by removing the louvred cover at base of the machine.

Suction Strainer - inspect oil strainer every twelve months. The strainer is accessible, having released the screws in tank cover, if necessary wash in paraffin (Replacement L820/5020).

Sludge Tray - whilst lower cover is removed, check tray located under main frame once every twelve months.

9.6 CLEANING

Under normal operation, all visible working parts should be regularly cleaned of foreign matter, thus preventing excessive wear and possible failure.

9.7 REGULAR MAINTENANCE

- Daily** - Before starting machine -
Check fluid level in tank - top up as necessary.
Check oil level in oil pump - top up as necessary.
Check condition of all blades, punch and die.
Check surrounding work area is tidy, remove any off-cuts, slugs from floor area.
Clean off any mill scale which may have collected around the cutting apertures.
- Weekly** - But depending on work load
Examine power cable and foot pedal cable for damage or chafing.
Check movement of machine is smooth when running under no load condition.
- Monthly** - Check arm adjustment for any slackness - see page 31.
- Yearly** - Change hydraulic fluid, inspect oil suction strainer.

9.8 HYDRAULIC FLUID

Fill to top level of inspection glass. Use only mineral oil as recommended or equivalent.

Castrol	Hyspin AWS32-6018
B. P.	Energol HLP32
Shell	Pollus 37
Mobil	DTE 24
Esso	Nuto H32

9.9 OILING LUBRICANT

Check oil level in pump reservoir daily, operate pump 2/3 times daily.

Castrol	Magna DR 220
Shell	Tomma T220
B.P.	Energol GHI 220
Mobil	Vactra Oil No. 4
Esso	Febis K220

Note: Oiling system applicable to ‘shear End’ of machine only.

‘Punch End’ lubrication - only requires an occasional application of light grease to the flat on the punch ram.

Lubricant Check

Before operating machine, the following important checks should be made.

- The Hydraulic fluid is at top level of inspection glass.
- The oil pump has been operated, and that there is oil pressure indicated at the pressure gauge, check oil level in pump.

9.10 MACHINE RAM & ARM ADJUSTMENT

Following an initial working in period (say 5/6 days) the machine may require settlement adjustment to be carried out.

Punch Ram

The alignment of the ram is guided by a ‘Ram Guide Pad’; this pad may require attention to adjustment.

Adjusting screws are located at the left - hand side of the punch end.

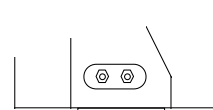

Adjusting Ram

Firstly remove punch, then ensure equal adjustment to both screws, lock nuts after adjustment; test by working ram (say 6 times). DO NOT over-adjust the screws, check pad side loading by operating in the 'INCH' mode, if ram does not advance, pad has been over-adjusted, correct and try again.

Adjusting Shear Arm

Isolate machine before making any adjustments.

Adjustment to pressure pads are made from the cutting side of the arm (i.e. the feed side of the machine).

1. Slacken locking nuts at the three pad positions only (M24 lock nuts).
 2. Turn adjusting screws clockwise until slight resistance is felt
 3. Tighten lock nuts and test movement of arm.
 4. Re-adjust blades before use.
- N. B. The arm should be adjusted prior to any adjustment of the shear blade.

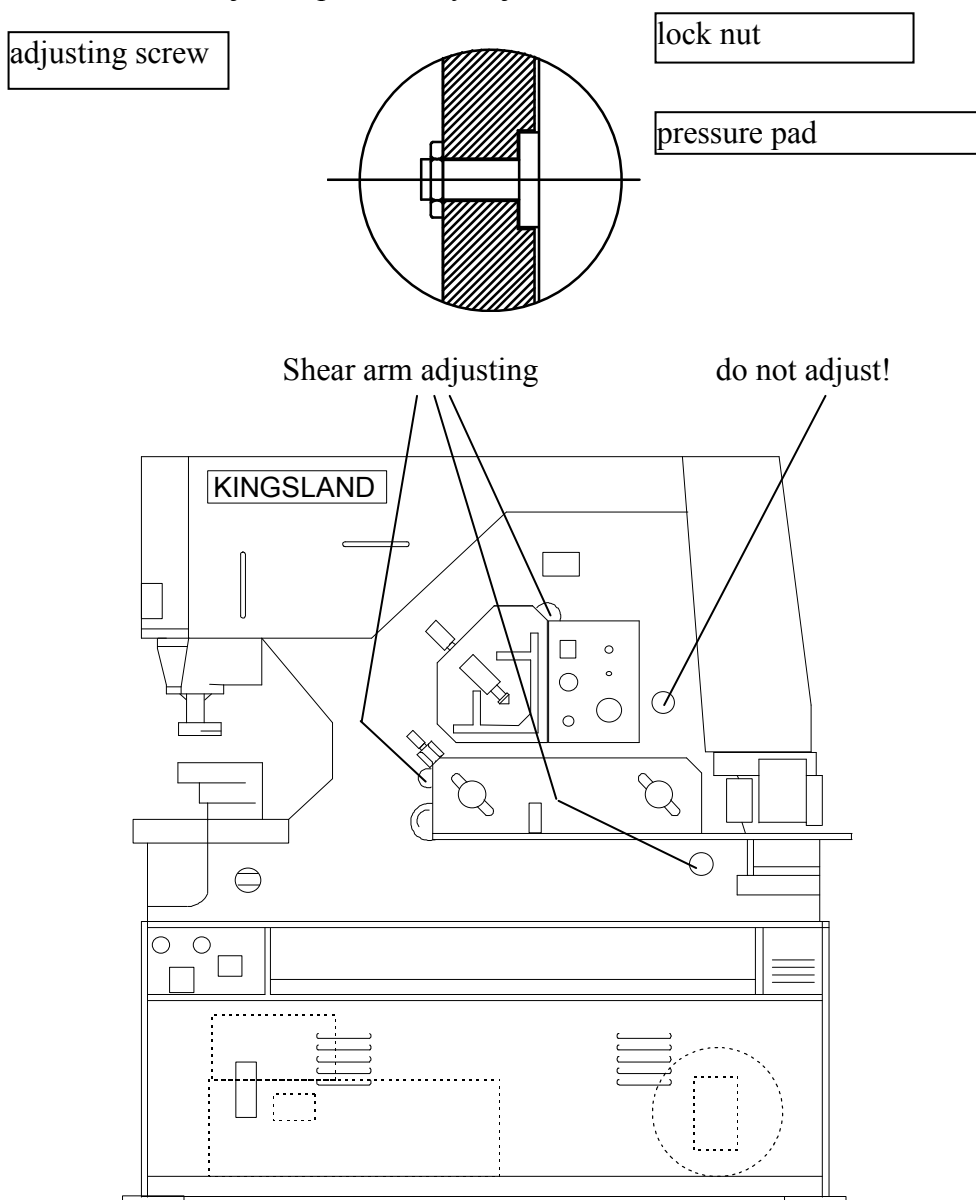

MULTI95 HYDRAULIC STEELWORKER

NOTCH END

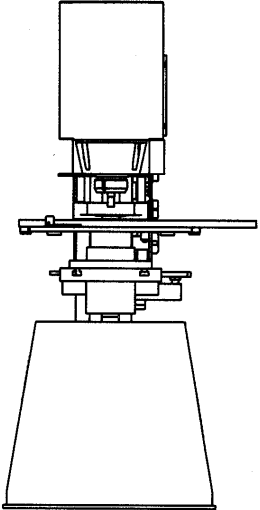
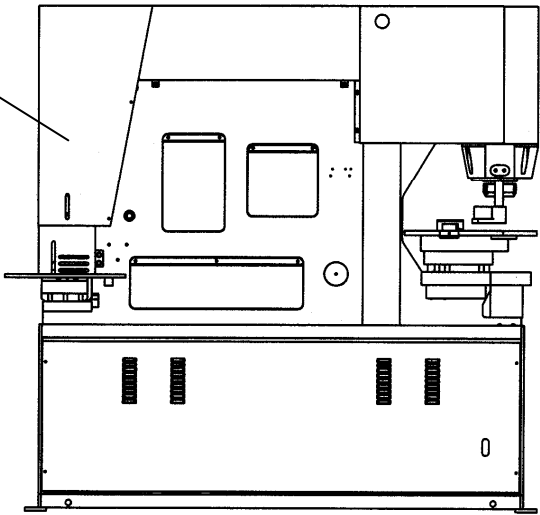

ANGLE CROPPING

SECTION CROPPING

PUNCH END

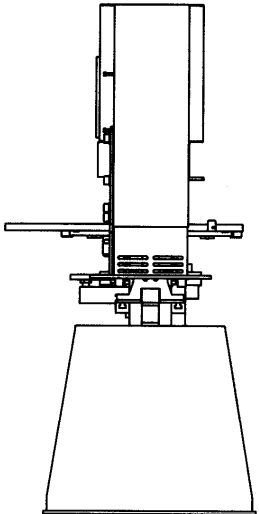
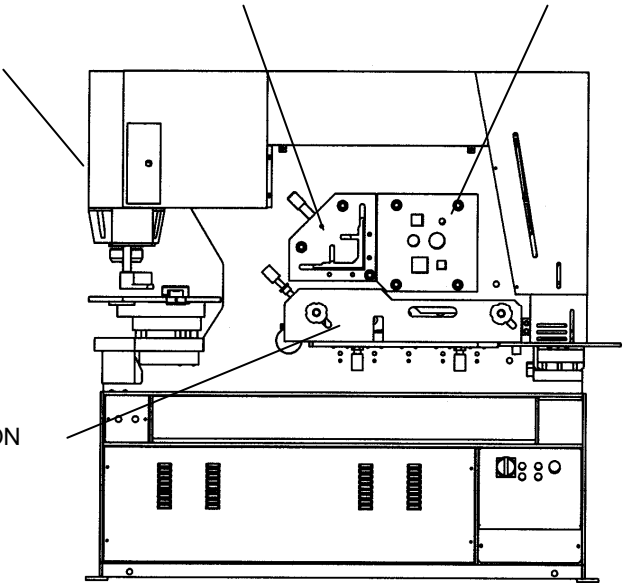

SHEAR STATION

9.11 PARTS LIST

When ordering spares always quote model, type and Serial Number of Machine.

Nr.	Part No.	Description	No. off
1	2366	Clevis	1
2	2379	Main pivot bush	1
3	2381	Cylinder pin	1
4	2380	Clevis pin	1
5	2461	Clevis packing	1
6	2864	Punch cylinder clamp short	2
7	4103	Pivot locator	1
8	2904	main pivot	1
9	3239	Front louvre cover	1
10	3242	Rear louvre cover	1
11	K205/0535	Bush	1
12	L815/7505	Punch cylinder	1
13	L815/7510	Shear cylinder	1
14	2079	Hold down adj screw	1
15	2393	Ram pressure plate	1
16	2097	Notch / shear guide	1
17	2203	Rect notch bolster	1
18	2256-2	Ram guide HSG	1
19	2257	Stripper top plate	1
20	2259	Stripper head	1
21	2407	Stripper pillar	2
22	2263	RAM guide pad	1
23	2403	Notch table plate	1
24			
25	2346	Manifold	1
26	2282	Table support block	2
27	2999	Notch bolster washer	4
28	2389	Shear blade (body)	1
29	2395	Shear hold down	1
30	2397-1	Angle H/D Assym	1
31	2401	Angle blade (arm)	1

MULTI95 HYDRAULIC STEELWORKER

No.	Part No.	Description	No. off
32	3975	Section aperture cover	1
33	3974	Angle aperture cover	1
34	2433	Limit switch actuator	3
35	2435	Rod fixed stop	3
36	5825	Notch end guard	1
37	2394	Punch retaining ring	1
38	2732	Shear support adj screw	4
39	2266	Screw end piece	1
40	2796	Angle H/D screw	1
41	2835	Angle wear bar	2
42	4256	Punch bolster	1
43	2999	Punch bolster washer	6
44	2887	Stripper pivot sleeve	1
45	2890	Bolster washer	2
46	2914	Shear blade (arm)	1
47	3201	R&SQ blade (body)	1
48	3202	R&SQ blade (arm)	1
49	3397	Shear table	1
50	3537	Notch die	1
51	5821	P/E Cover (body)	1
52	5820	P/E cover (s/p)	1
53	4960	Top cover	1
54	5824	Notch end cover	1
55	3930	Notch die	1
56	4170	Punch front perspex cover	1
57	3683	PE cover rear	1
58	3973	Shear aperture cover	1
59	L515/3240	Tank	1
60	L830/2444	Flex Pipe (Tank - Pump)	1
61	L830/2443	Flex Pipe (Pump - Valves)	1
62	L830/2442	Flex Pipe (Relief return)	1
63	L830/2440	Flex Pipe (A - Punch cylinder)	1
64	L830/2440	Flex Pipe (B - Punch cylinder)	1
65	L830/2439	Flex Pipe (B – Shear cylinder)	1
66	L830/2438	Flex Pipe (A - Shear cylinder)	1
67	3929	section blade clamp	2
68	3931	Angle blade (body)	2

MULTI95 HYDRAULIC STEELWORKER

No.	Part No.	Description	No. off
69	87059	Material stop	1
70	87060	Table guide bolck	2
71	87061	Guide block retaining plate	2
72	87062	Material stop pad	1
73	87063	Guide block pad	2
74	4258	Punch table plate	1
75	87078	Punch table beam	1
76	87081	Front table fix plate	2
77	87096	material stop extension bar	1
78	9001 – 22	Round Punch 22mm	1
79	9023 – 23	Round die 22mm	1
80	9036	Punch adaptor	1
81	K405/7320	7.5 KW 230 / 400 Euro Volt Motor	1
82	K410/1045	24V Elec. Box	1
83	K410/4750	Lamp	1
84	K410/7009	Foot switch	2
85	K411/319938	Micro switch cover	4
86	K411/338282	Micro switch	4
87	K705/1908	Kipp handle	2
88	K705/3006	Punch stripper securing spring	1
89	K715/6510	Pressure gauge	1
90	K715/7040	oil pump	1
91	L605/2626	Notch / shear guide	3
92	L605/3203	section hold down	1
93	L605/4163	Punch front guard t/plt	1
94	L820/1505	Bell housing	1
95	L820/2020	Coupling	1
96	L820/4530DC	By-pass control valve	1
97	L820/4510DC	Punch / shear control valve	2
98	L820/45350	Relief valve	1
99	L820/5020	Suction strainer	1
100	L820/5030	Diffuser	2
101	L820/5041	Filler	1
102	L910/55000	Pump	1

10 CIRCUITS

10.1 HYDRAULIC CIRCUIT

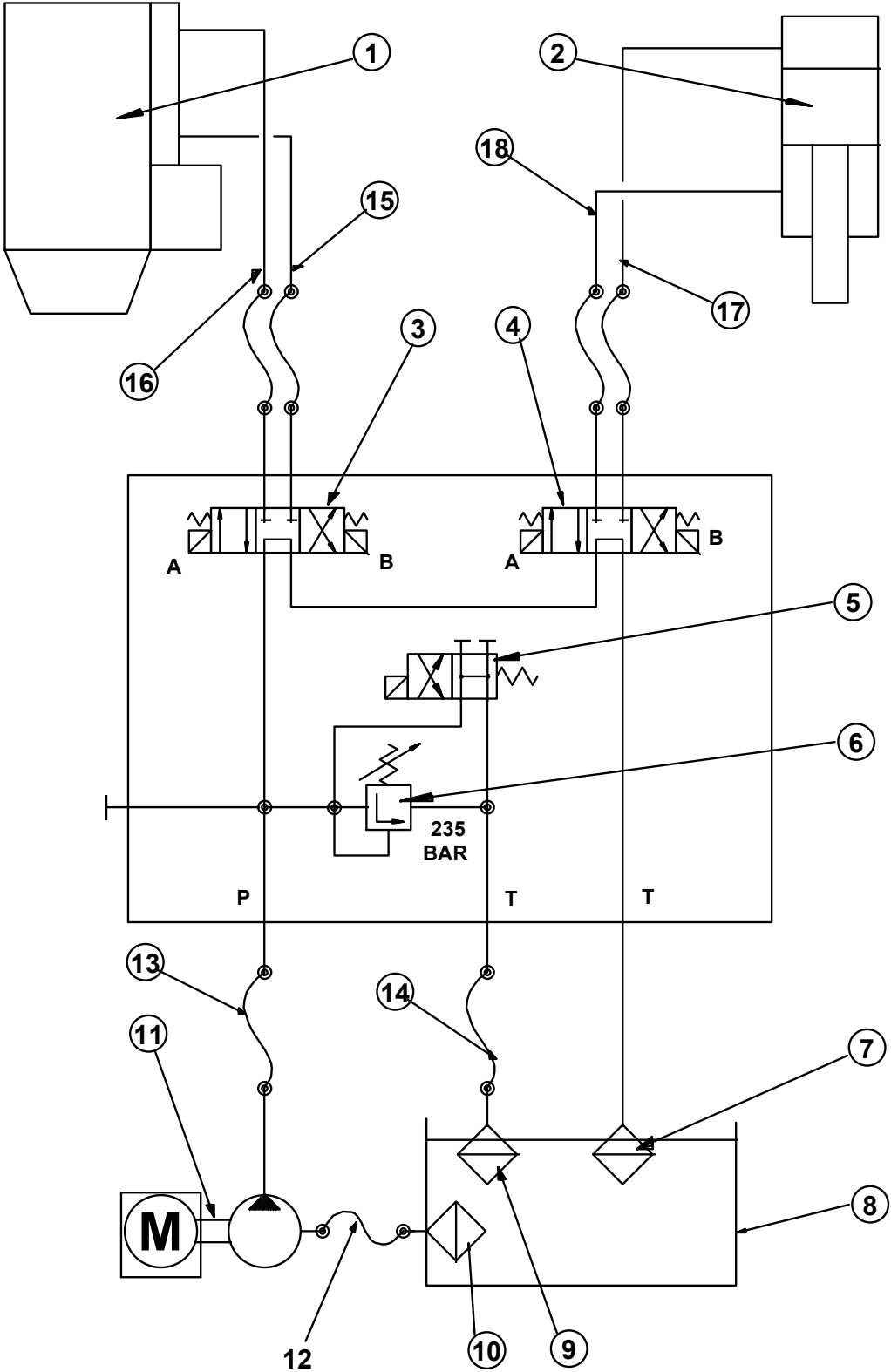

Parts of the Hydraulic Circuit:

No.	Part No.	Description	No. off
1	L815/7505	Punch cylinder	1
2	L815/7510M	Shear cylinder	1
3	L820/4517DC	Punch control valve	1
4	L820/4517DC	Shear control valve	1
5	L820/4514DC	By-pass control valve	1
6	L820/45370	Relief valve	1
7	L820/5030	Diffuser	1
8	2273	Tank	1
9	L820/5030	Diffuser	1
10	L820/5020	Suction strainer	1
11	K715/7040	Pump	1
12	2444	Flex Pipe (Tank - Pump)	1
13	2443	Flex Pipe (Pump - Valves)	1
14	2442	Flex Pipe (Relief return)	1
15	2440	Flex Pipe (B - Punch cylinder)	1
16	2440	Flex Pipe (A - Punch cylinder)	1
17	2439	Flex Pipe (B - Shear cylinder)	1
18	2438	Flex Pipe (A - Shear cylinder)	1

10.2 ELECTRICAL CIRCUIT

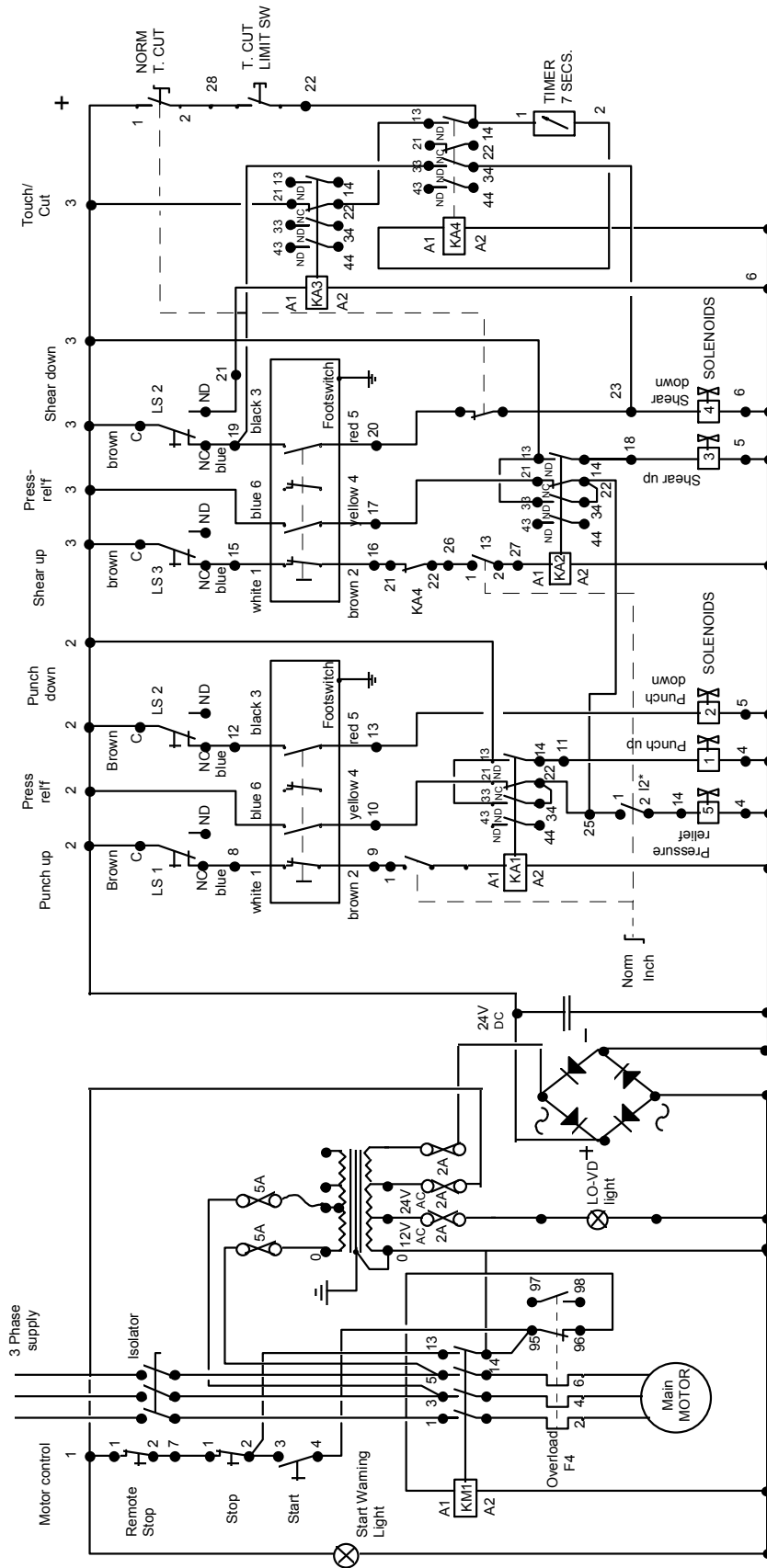

*THIS SWITCH IS NOT FITTED TO 160/175XS MACHINE!

11 SPECIAL TOOLING

11.1 90° VEE NOTCH TOOLING ARRANGEMENT

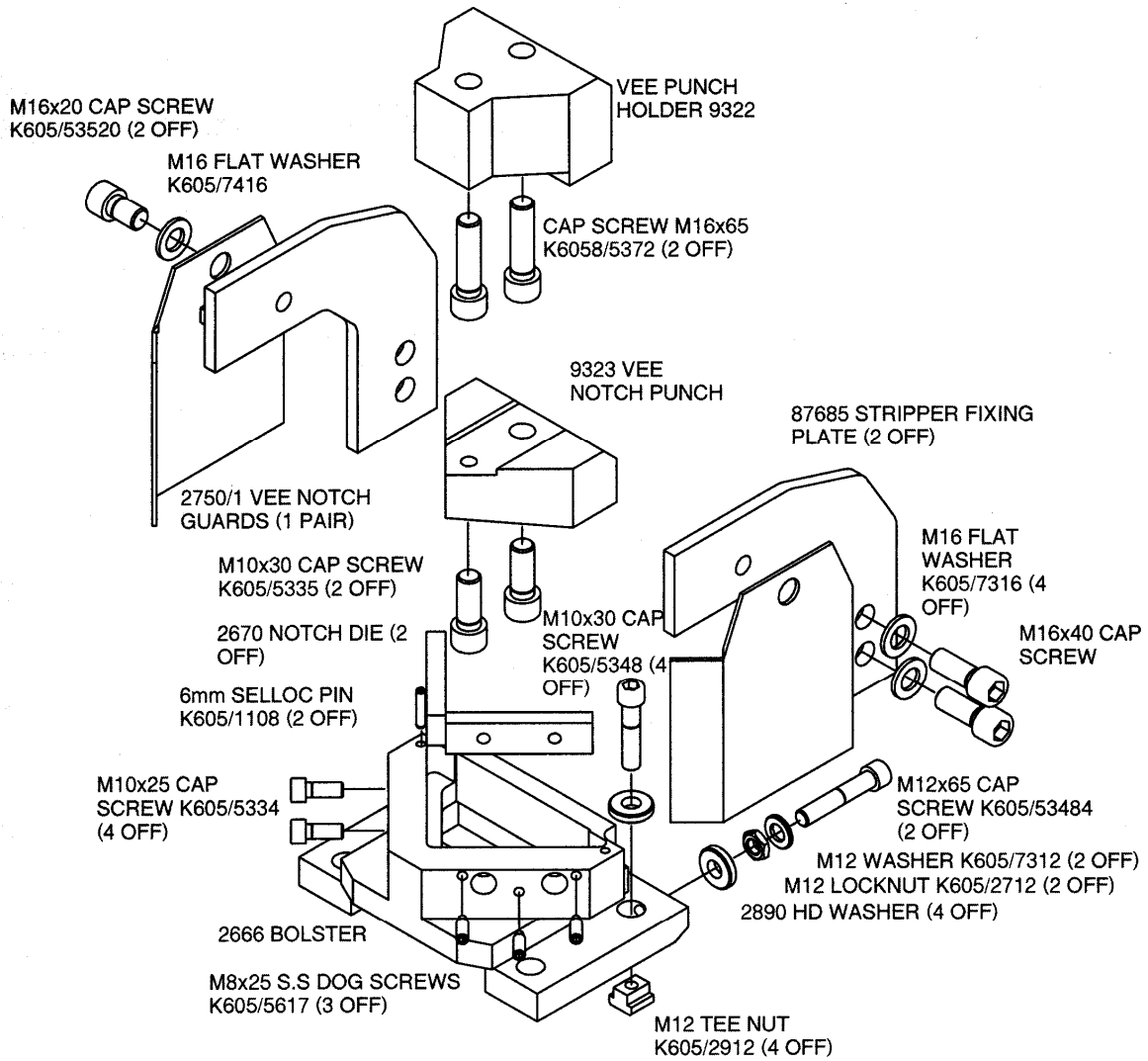

11.2 WEB PUNCHING ARRANGEMENT FOR 'I' & 'U' SECTIONS

WHEN PUNCHING 'I' SECTION
REMOVE STD STRIPPER HEAD ASSY
FIT SPEC EXTENDED PILLARS 87140
WITH M20 LOCKNUTS

TOTAL HEIGHT OF
UNIT INCLUDING DIE
100mm

MIN SECTION 60 'I' OR 'U' SECT

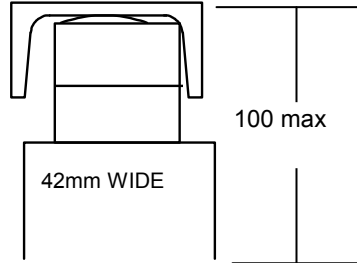

MIN SECTION 120 'I' OR 'U' SECT

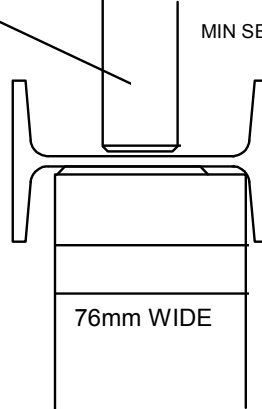

M12x60 CAP SCREW
2 OFF
K605/53482



DIE HOLDER PLATE
9401

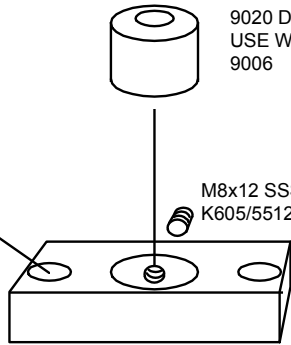

9020 DIE (3-19)
USE WITH PUNCHES
9006

M8x12 SSS (CUP)
K605/5512

DIE SUPPORT PLATE
9402

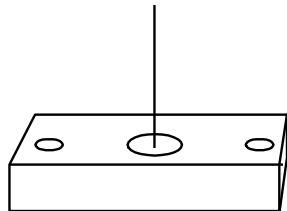

M10x12 SSS (CUP)
K605/55190

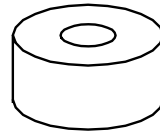

9023 DIE (5-38)
USE WITH PUNCHES
9006

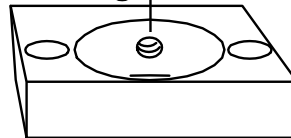

DIE HOLDER PLATE
9403

* CAP SCREW
M16x60
K605/5358
(4 OFF)

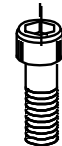

* BOLSTER
CLAMP
2844 -(4 OFF)

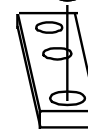

* M16 TEE NUT
K605/2916
(4 OFF)



NOTE- PUNCHES & DIES NOT INCLUDED
WITH UNIT

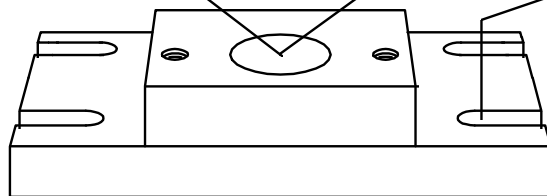

9399 BOLSTER

* THESE ITEMS ARE FROM STANDARD PUNCH BOLSTER ASSY

11.3 LARGE HOLE PUNCHING

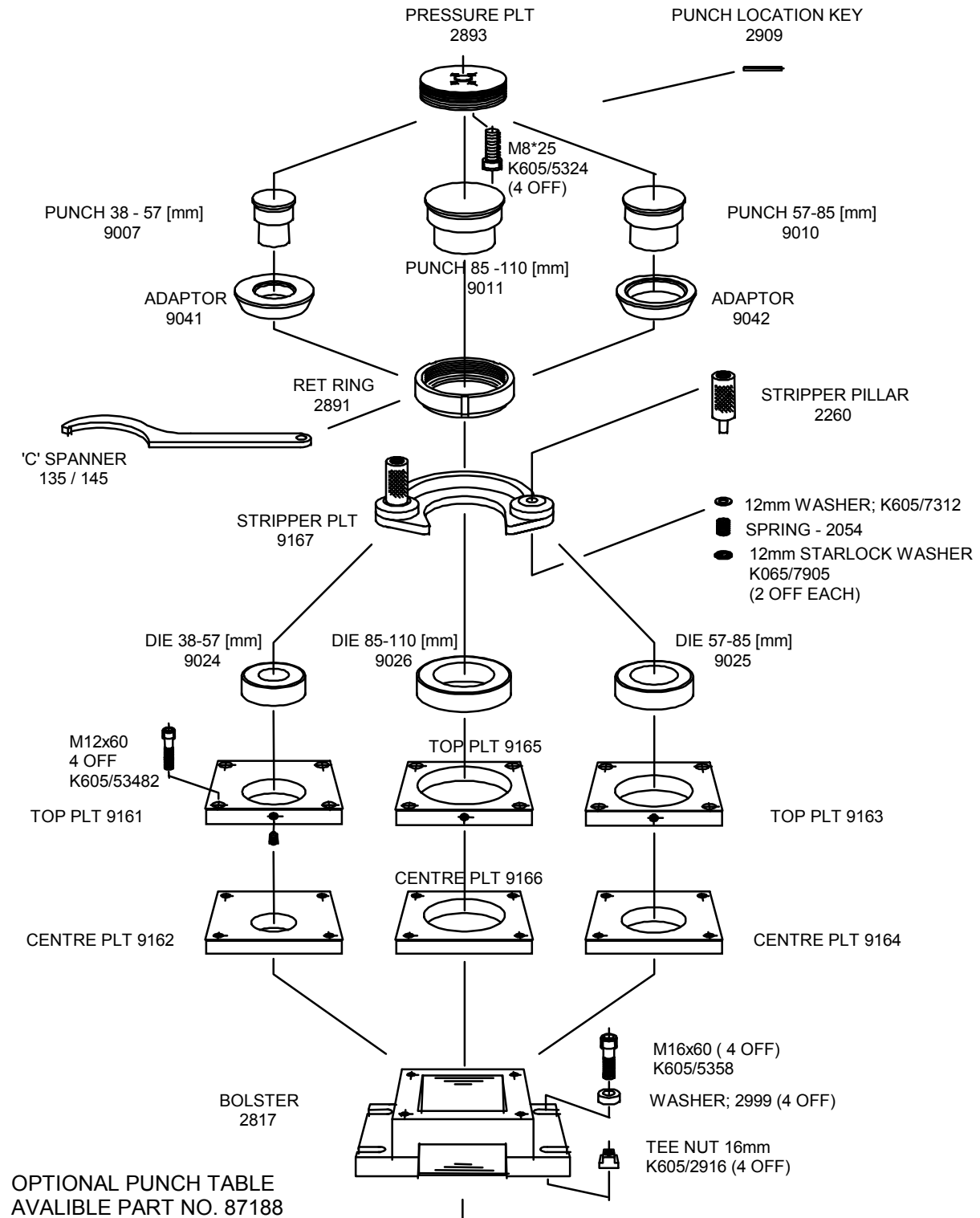

11.4 BAR BENDING UNIT

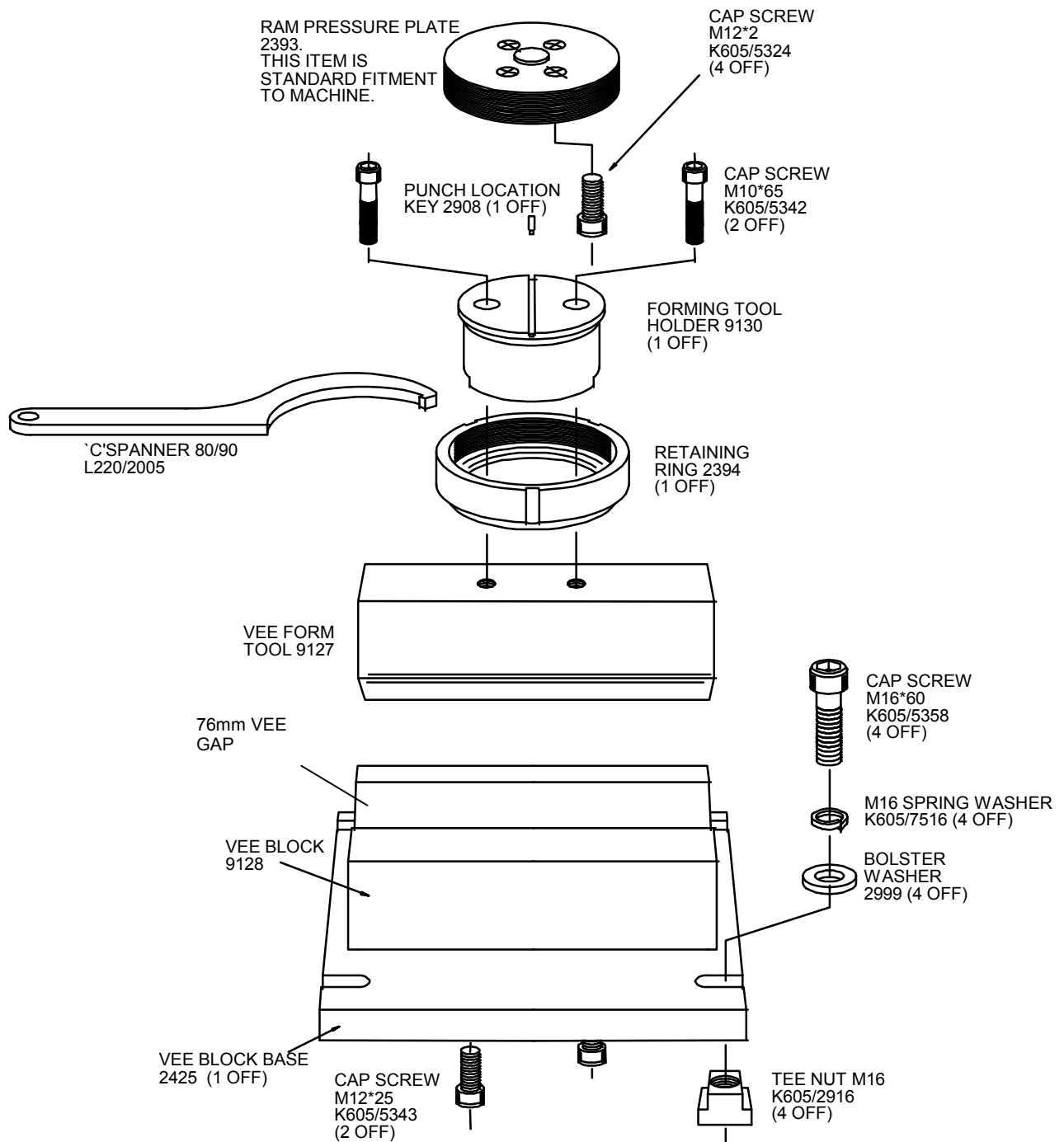

To calculate the tonnage required for bending use the following formula:

$$\text{Tonnage} = \frac{\text{plate thickness}^2 \times 1.42 \times \text{plate length}}{1000 \times \text{vee gap}}$$

When bending always ensure work-piece is positioned central on VEE Block to avoid side loading ram. Air bending only. Adjust down stroke limit switch to avoid unnecessary pressuring of machine.

Capacity: 250 * 20 [mm²]

11.5 SHEET BENDING UNIT

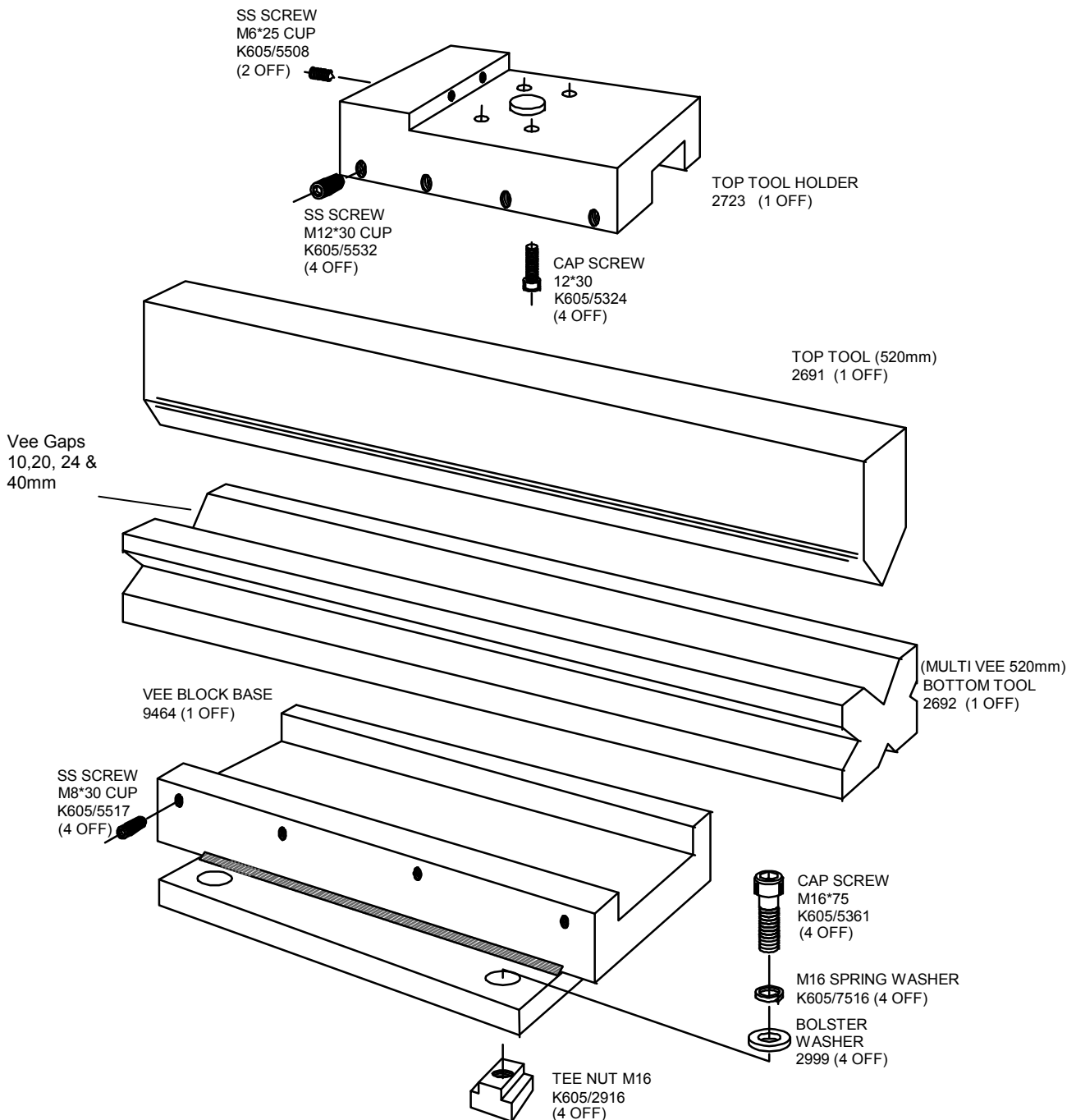

When bending always ensure work-piece is positioned central on VEE Block to avoid side loading ram. Air bending only. Adjust down stroke limit switch to avoid unnecessary pressuring of machine. To calculate the tonnage required for bending use the following formula:

$$\text{Tonnage} = \frac{\text{thickness of plate}^2 \times 1.42 \times \text{width of material}}{1000 \times \text{vee gap}}$$

Capacity: 500 * 3 [mm²]

11.6 NOTCH END PUNCHING

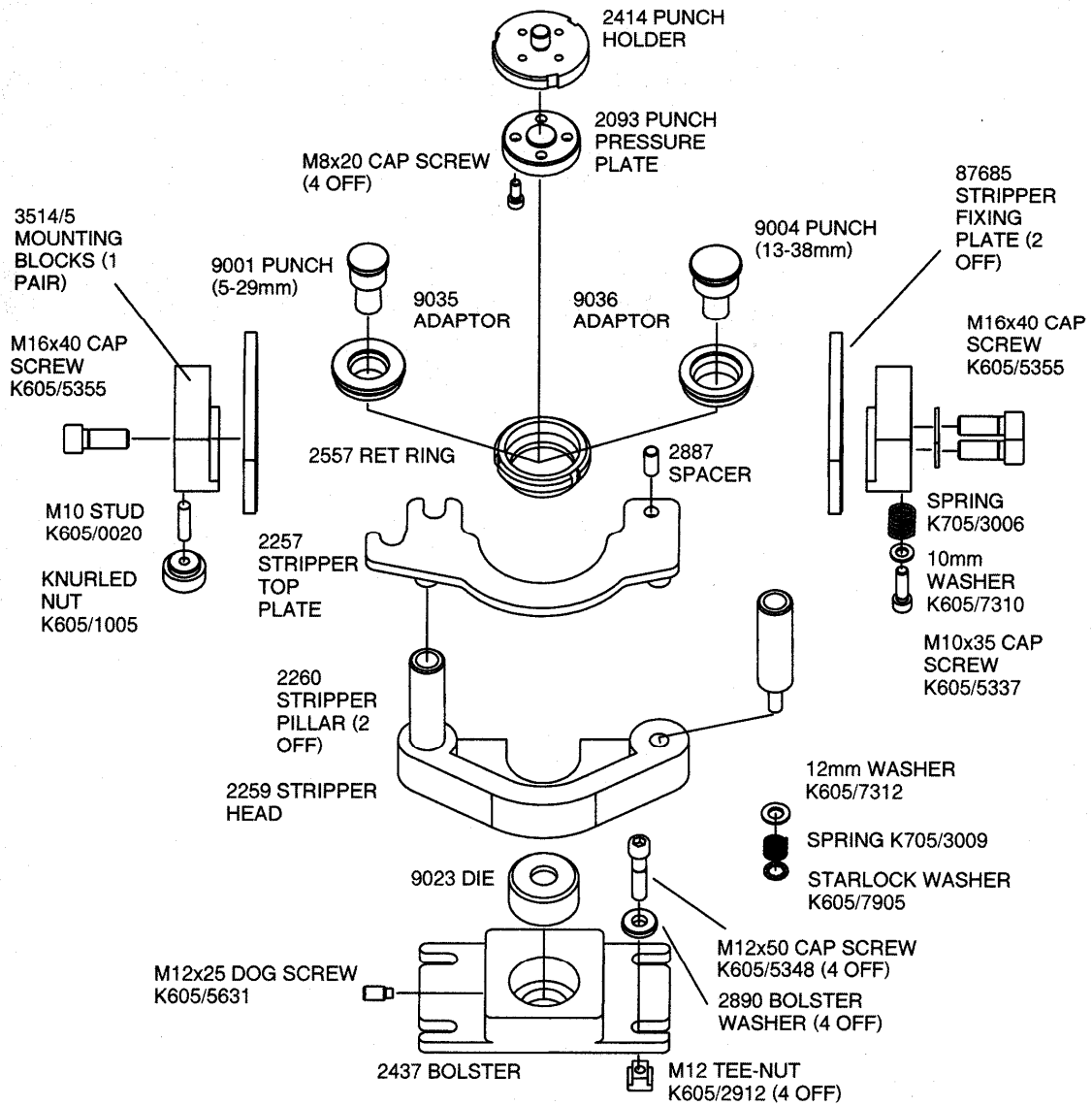

11.7 SWAN NECK BOLSTER

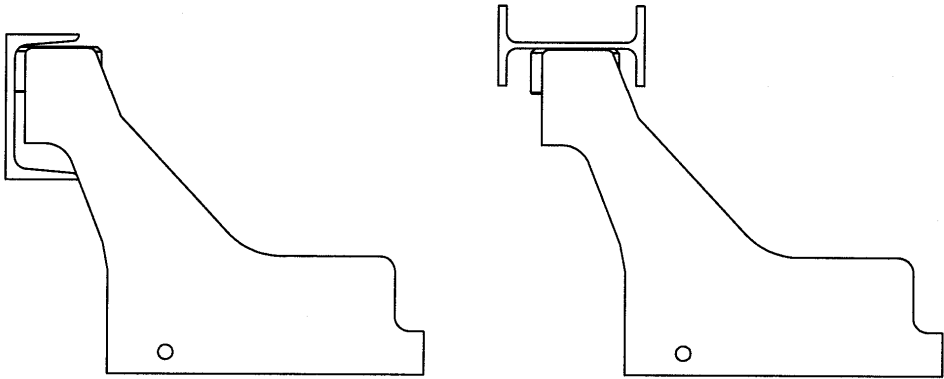
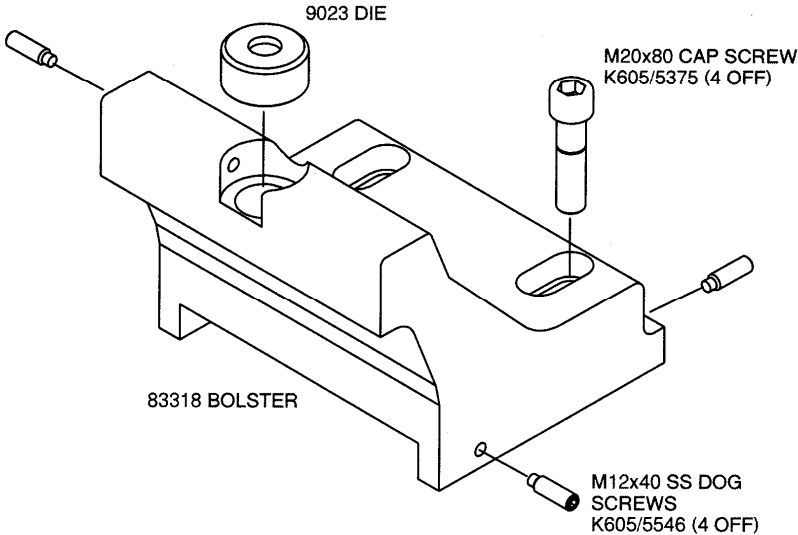

11.8 DOVETAIL QUICKCHANGE ATTACHMENT

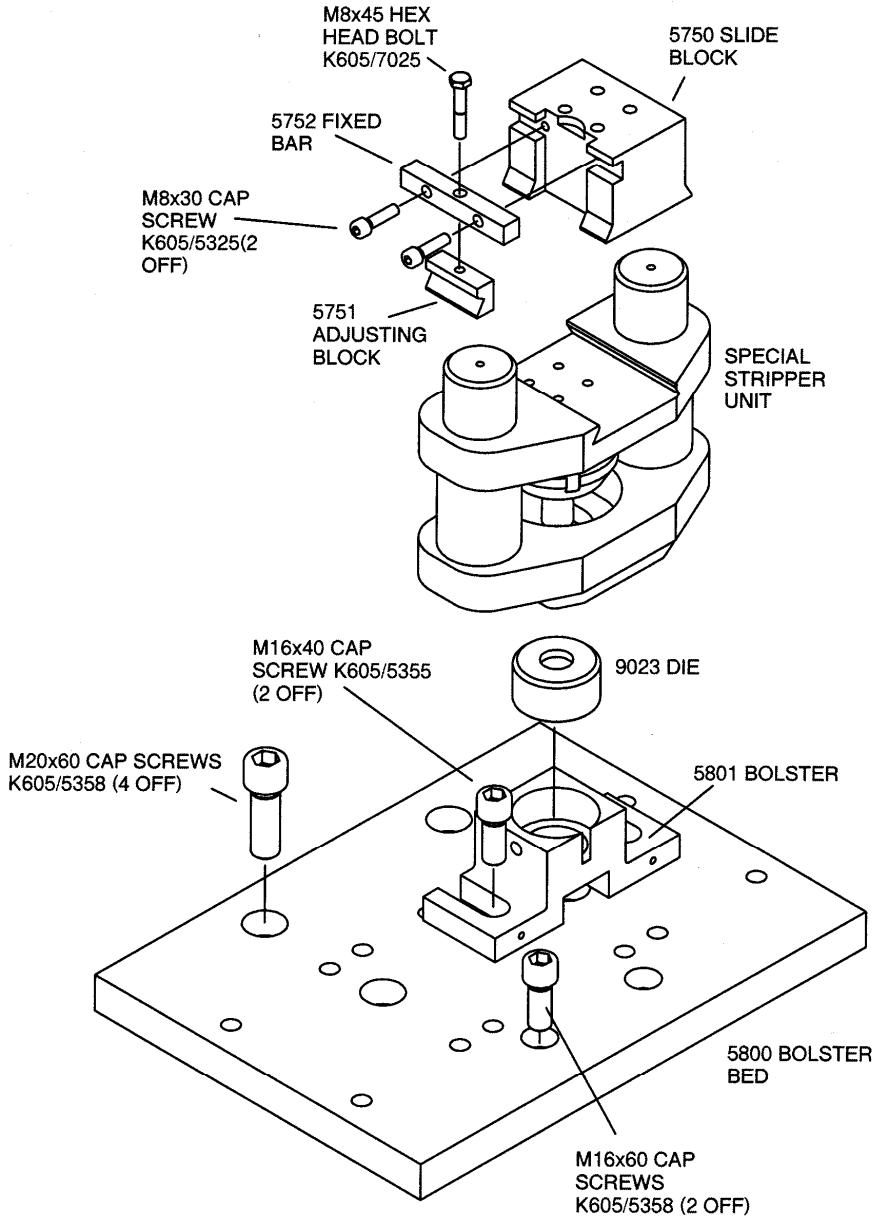

12 SOUND LEVEL TEST

12.1 MAX. SOUND PRESSURE LEVEL

RESULT SHEET

MACHINE UNDER TEST	MONITORING POSITION	TIME IN USE	5 min. LEQ	MAX SPL	MIN SPL	AVG SPL	COMMENTS
Multi 95	1m	-	-	73 dB	-	-	-
Multi 95D	1m	-	-	73 dB	-	-	-
95P	1m	-	-	73dB	-	-	-

13 MANUAL APPENDIX

13.1 POSITIONING OF THE PUNCH STRIPPER

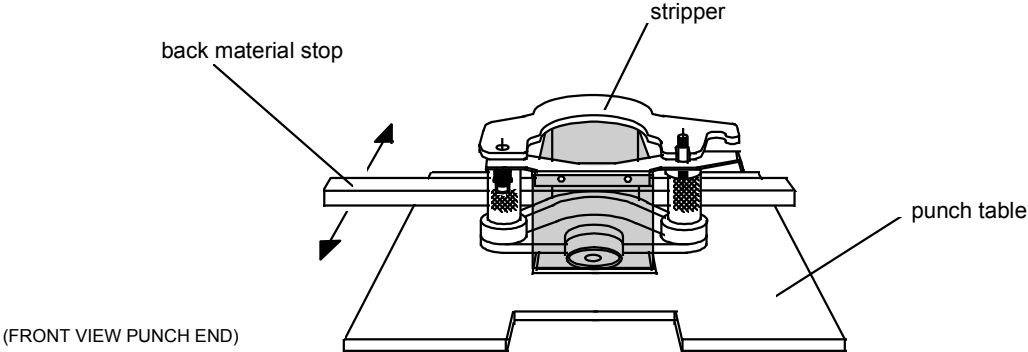

NORMAL STRIPPER POSITION

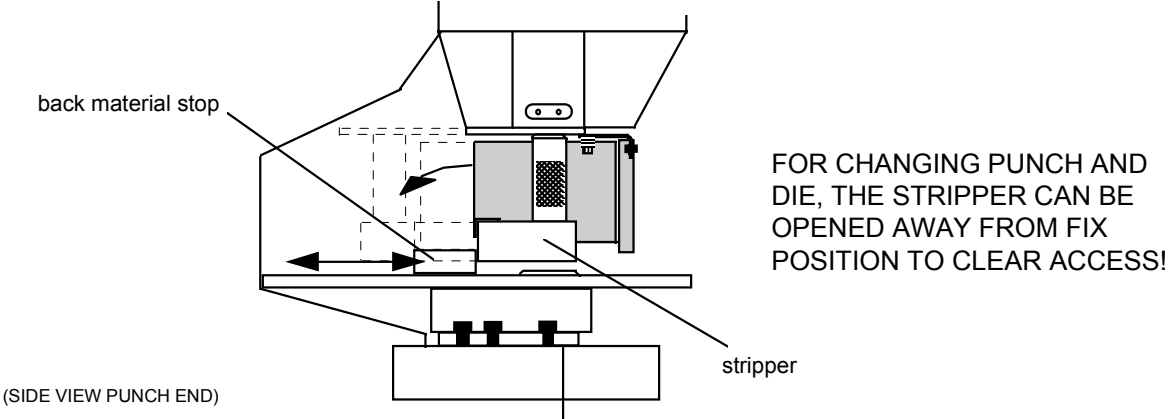

REVERSED STRIPPER POSITION

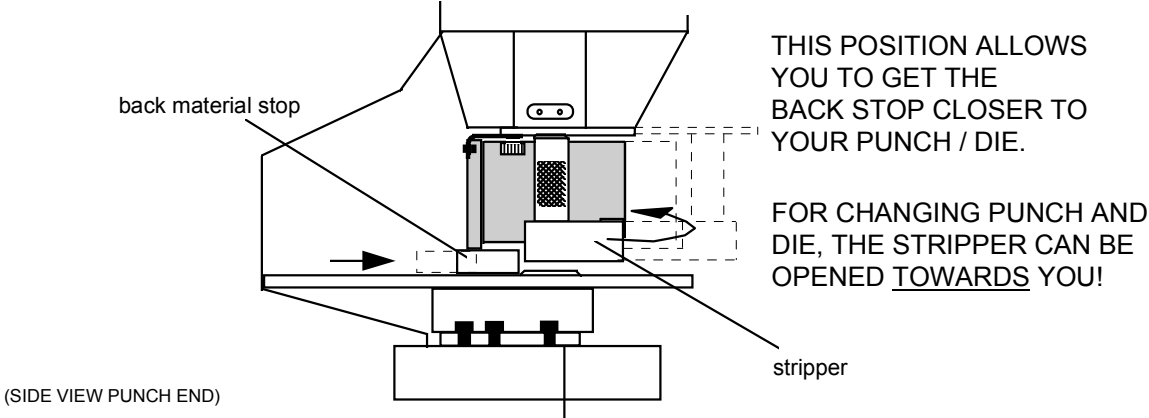

13.2 MITRING ANGLE 45 DEGREES

Since the introduction of the requirements for health and safety, the accessibility and distance between hold-downs and blades have been amended.

To this effect the operation of mitring angle in the angle cutting station requires the following simple hold-down adjustment.

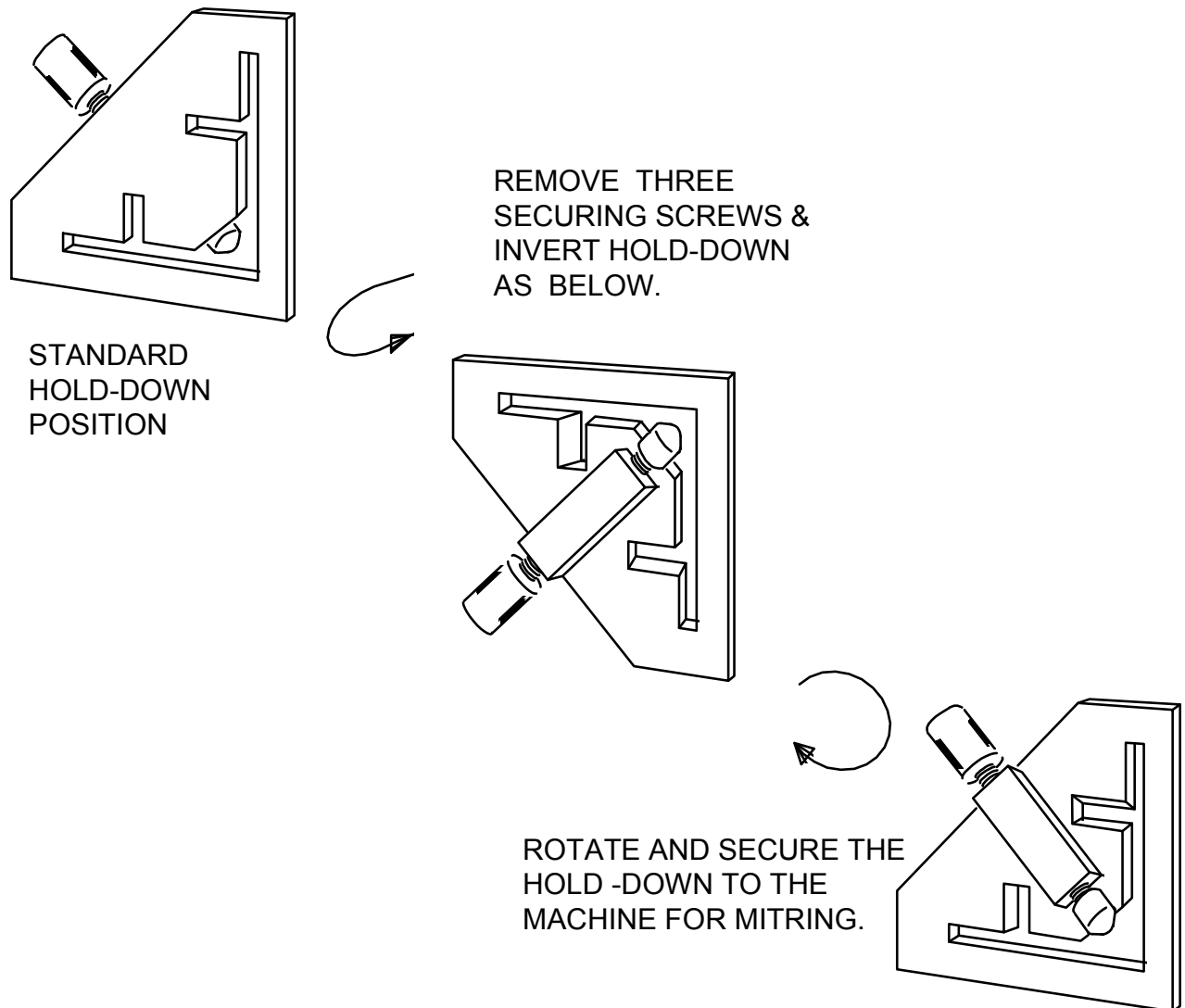

Once the hold-down is secured for mitring as position 3, it is also possible to use the hold-down for cutting angle at 90 degrees if required.