

Stainless Steel Counter

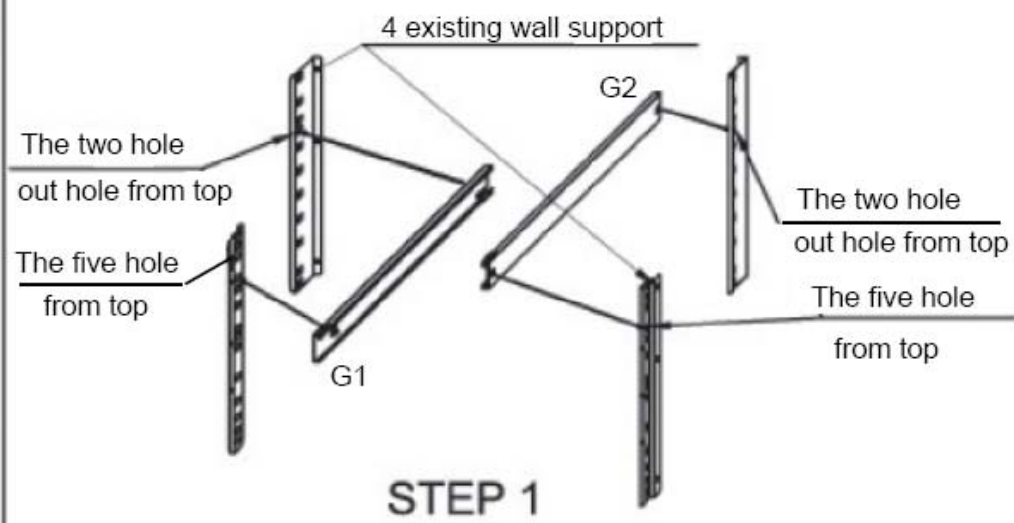

Installation, Operation & Maintenance Manual

SET2 DRAWER ASSEMBLY GUIDE

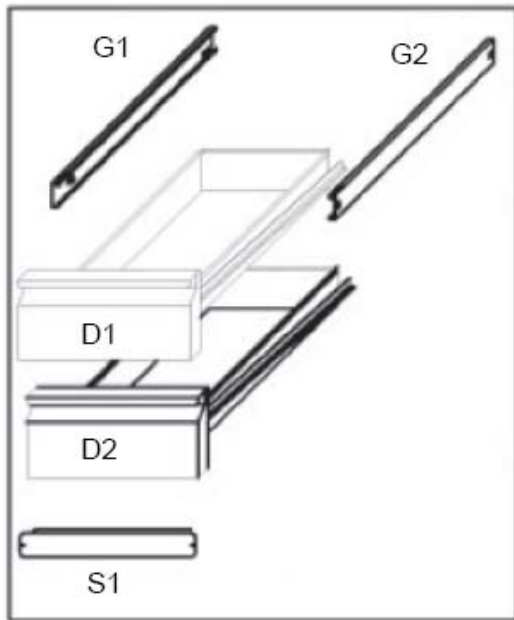

- PARTS LISTS**
 G1X2-slider guide left
 G2X2-slider guide right
 D1-1st drawer
 D1-2ed drawer
 S1-bridge beam
 D1=D2

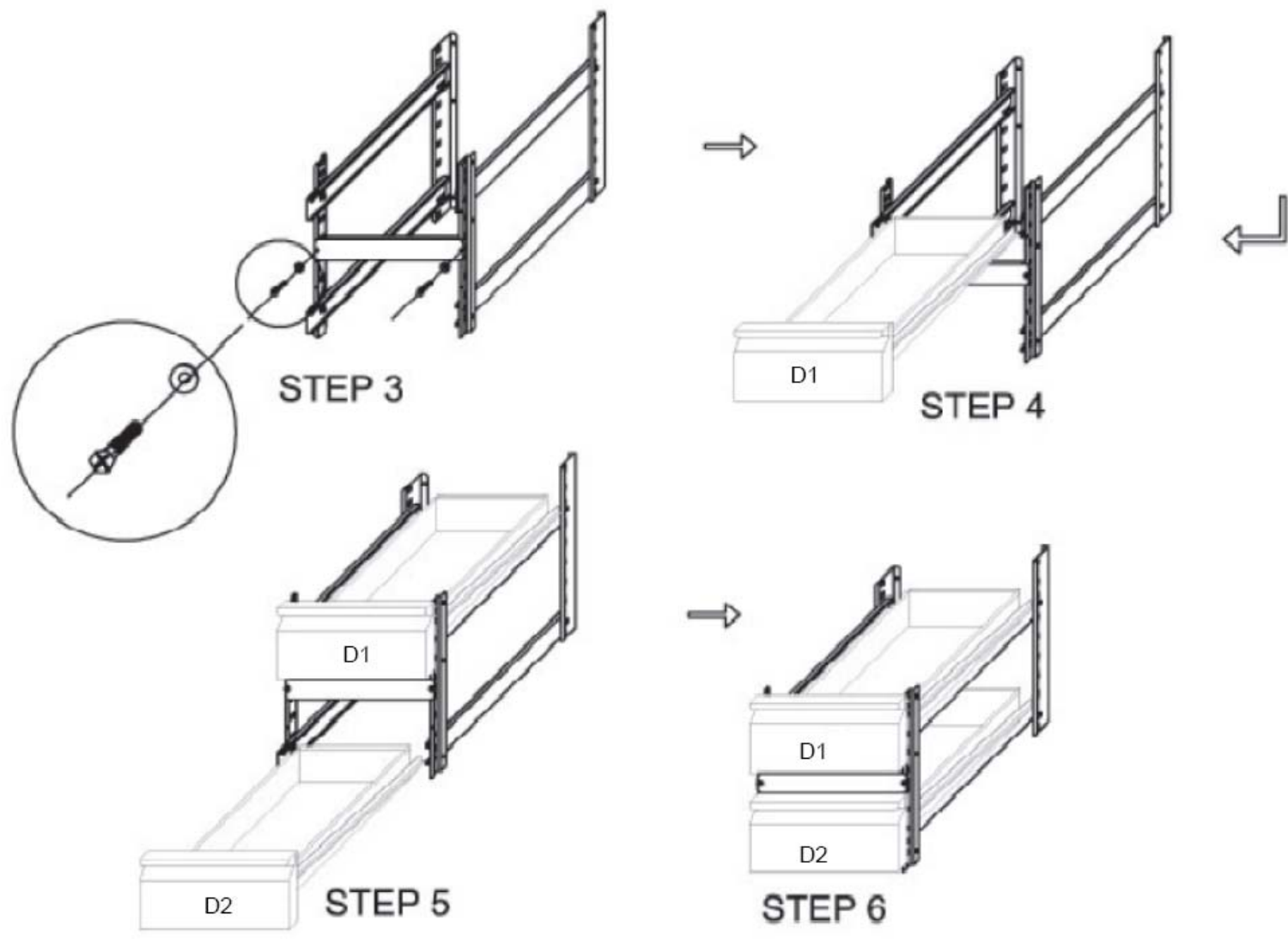
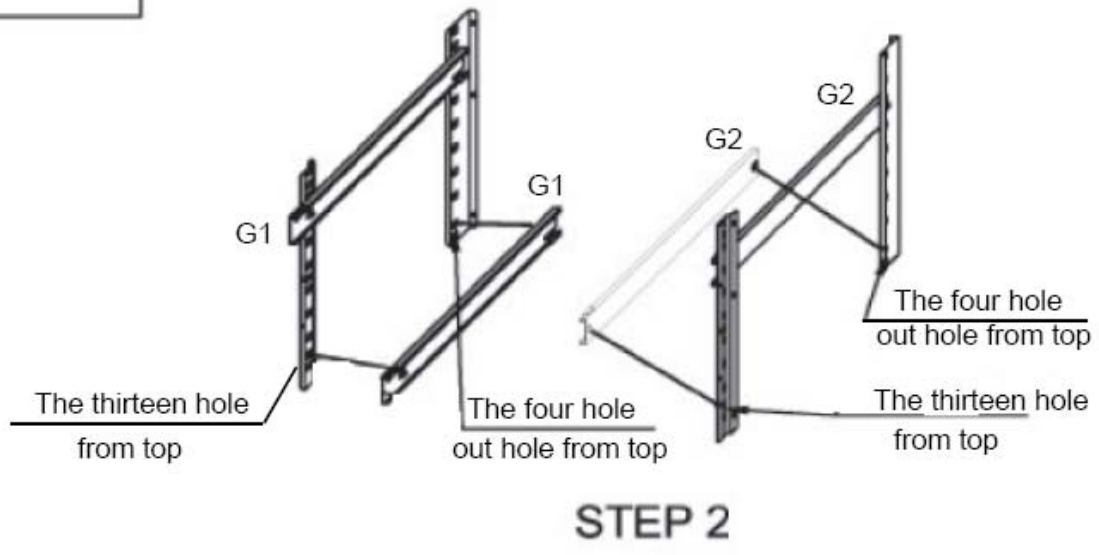

SET 3 DRAWER ASSEMBLY GUIDE

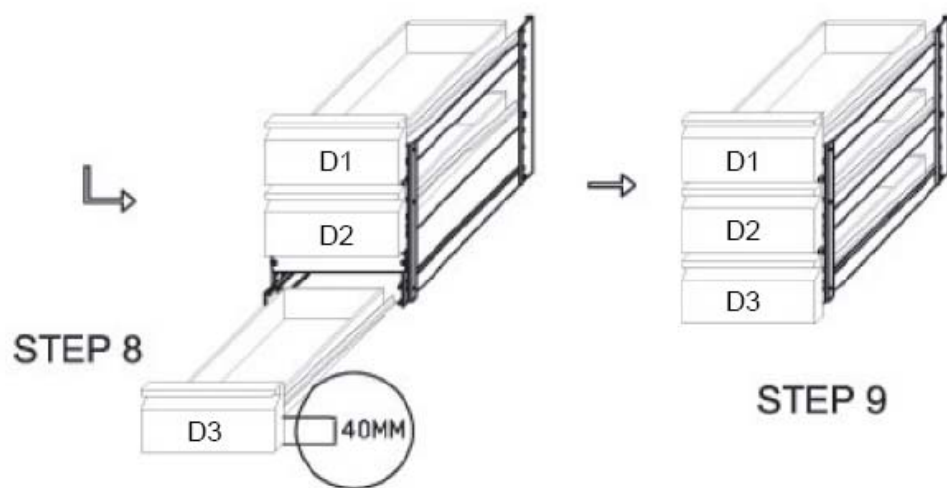
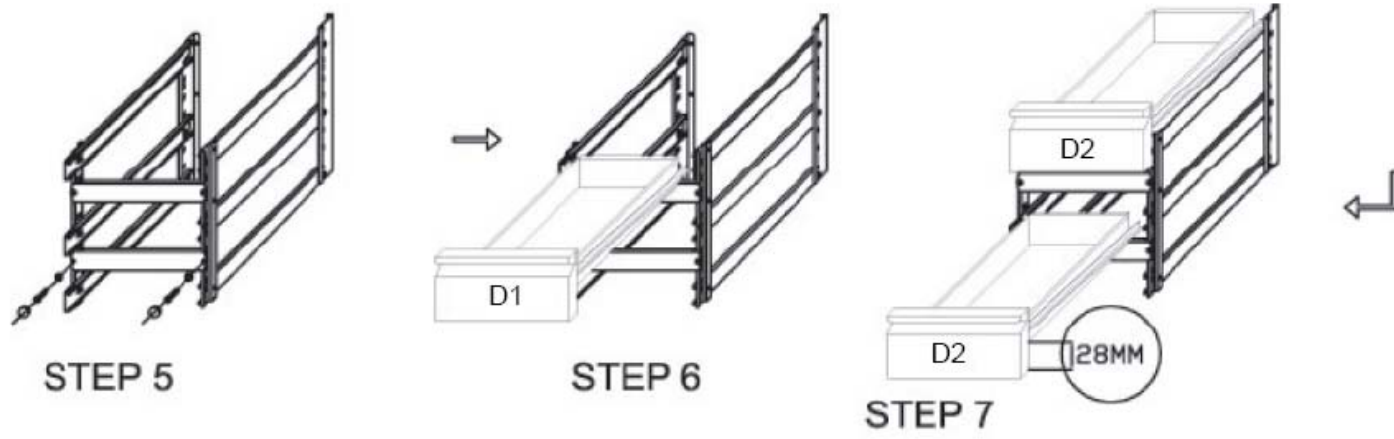
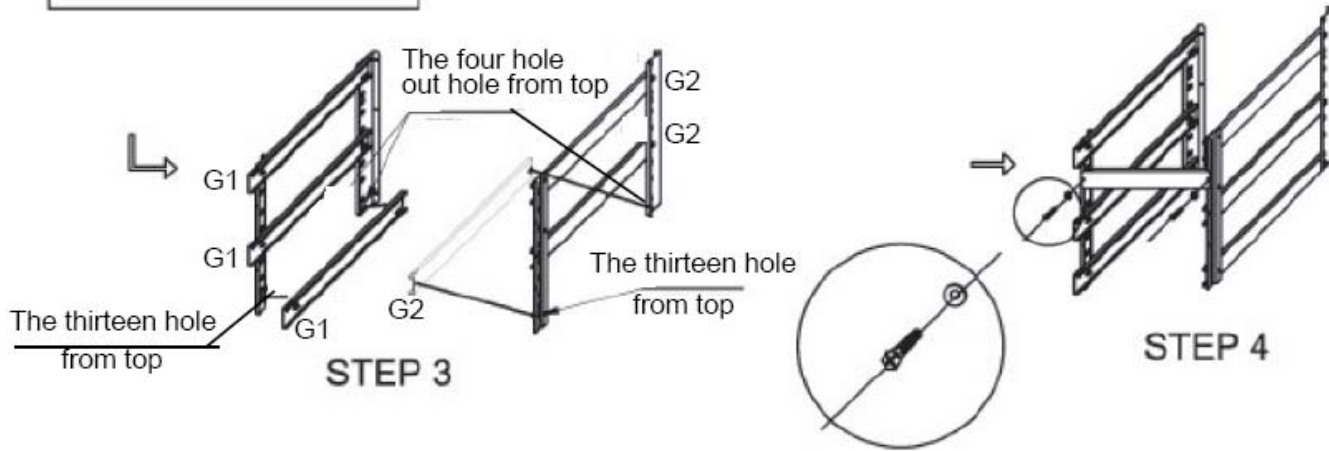
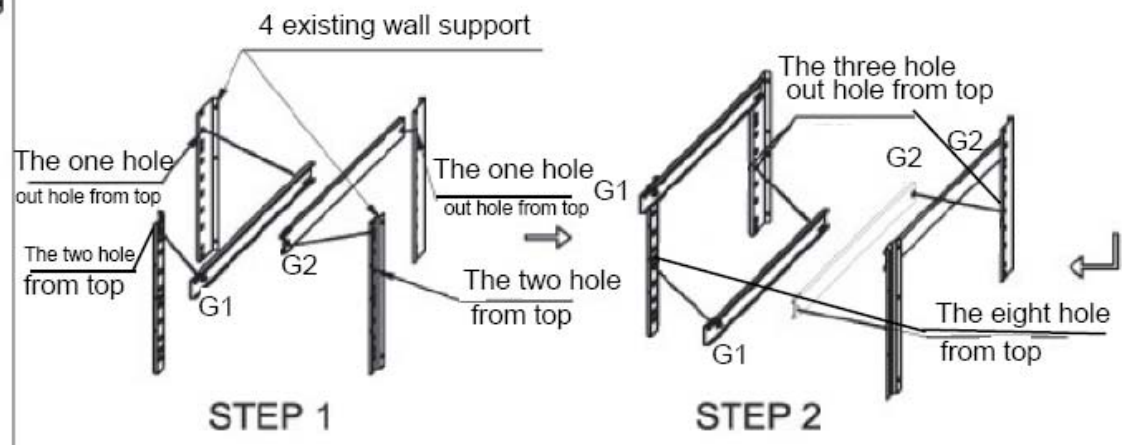
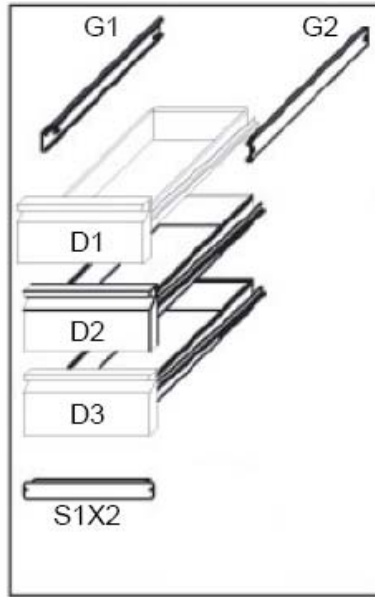

PARTS LISTS

- G1X3 slider guide left
- G2X3 slider guide right
- D1 1st drawer
- D2 2nd drawer
- D3 3rd drawer
- S1X2 bridge beam
- D1=D2

Safety Tips

- Position on a flat, stable surface.
- A service agent/qualified technician should carry out installation and any repairs if required. Do not remove any components or service panels on this product. Consult Local and National Standards to comply with The following:
 - Health and Safety at Work Legislation
 - BS EN Codes of Practice
 - Fire Precautions
 - IEE Wiring Regulations
 - Building Regulations
- DO NOT use jet/pressure washers to clean the appliance.
- DO NOT use the appliance outside.
- DO NOT use this appliance to store medical supplies.
- DO NOT use electrical appliances inside the appliance. (e.g. heaters, ice-cream makers etc.)
- DO NOT stand or support yourself on the base, drawers or doors.
- DO NOT allow oil or fat to come into contact with the plastic components or door seal. Clean immediately if contact occurs.
- Bottles that contain a high percentage of alcohol must be sealed and placed vertically in the refrigerator.
- Always carry, store and handle the appliance in a vertical position and move by holding the base of the appliance.
- Always switch off and disconnect the power supply to the unit before cleaning.
- Keep all packing away from children. Dispose of the packaging in accordance with the regulations of local authorities.
- If the power cord is damaged, it must be replaced by an agent or a recommended qualified technician in order to avoid a hazard.

Introduction

Please take a few moments to carefully read through this manual. Correct maintenance and operation of this machine will provide the best possible performance from your product.

Pack Contents

The following is included:

- Refrigerator or Freezer
- Shelf guides (2 per door)
- Shelves (1 per door)
- Instruction manual

We pride ourselves on quality and service, ensuring that at the time of packing the contents are supplied fully functional and free of damage. Should you find any damage as a result of transit, please contact your dealer immediately.

Installation

Note: If the unit has not been stored or move in an upright position, let it stand upright for approximately 12 hours before operation. If in doubt allow to stand.

1. Remove the appliance from the packaging. Make sure that all protective plastic film and coatings are thoroughly removed from all surfaces.
2. Maintain a distance of 20 cm (7 inches) between the unit and walls or other objects for ventilation increase this distance if the obstacle is a heat source.

Note: Before using the appliance for the first time, clean the shelves and interior with soapy water.

3. Set the brakes on the castors to keep the appliance in position OR level the appliance by adjusting the screw feet.

Fitting the Shelves

1. Place one set of shelf guides on either side of the cabinet at the desired height.
2. Slide the shelf into place.
3. Repeat for the remaining shelves.

Note: This is vital for ensuring correct drainage of condensation.

Operation

Storing Food

To get the best result from your appliance, follow these instruction:

- Only store foodstuffs in the appliance when it has reached the correct operating temperature.
- Do not place uncovered hot food or liquid inside the appliance.
- Warp or cover food where possible.
- Do not obstruct the fans inside the appliance.
- Avoid opening the doors for prolonged periods of time.

Turn on

1. Close the door(s) of the appliance.
2. Ensure the power switch is set to [O] and turn on at the socket.
3. Switch on the power [I]. The current temperature within the the appliance is displayed.

Manual Defrost

The appliance will automatically run a defrost cycle every six hours.

Note: The cycle starts from the time the appliance is initially powered up.

To manually defrost the appliance:

1. Press and hold the DEFROST button for 5 seconds.
2. The defrost cycle will start immediately and the Defrost LET illuminates. The defrost will last a maximum of 30 minutes

Note: Starting a manual defrost also resets the automatic defrost timer.

3. The next automatic defrost will start six hours after the manual defrost has finished.

Cleaning, Care & Maintenance

- Switch off and disconnect from the power supply before cleaning.
- Clean the interior of the appliance as often as possible.
- Do not use abrasive cleaning agents. These can leave harmful residues.
- Clean the door seal with water only.
- Always wipe dry after cleaning.
- Do not allow water used in cleaning to run through the drain hole into the evaporation pan.
- Take care when cleaning the rear of the appliance. Sharp edges can cut.
- An agent or qualified technician must carry out repairs if required.

Cleaning the Condenser

Periodically cleaning the condenser can extend the life of the appliance. We recommend that our agent or qualified technician clean the clean the condenser.

Troubleshooting

If your appliance develops a fault, please check the following table before making a call to your retailer.

Fault	Probable Cause	Action
The appliance is not working	The unit is not switch on	Check the unit is plugged in correctly and switched on
	Plug and lead are damaged	Call your agent or qualified technician
	Fuse in the plug has blown	Replace the fuse
	Power supply	Check power supply
	Internal wiring fault	Call your agent or qualified technician
The appliance turns on, but the temperature is too high/low	Too much ice on the evaporator	Defrost the appliance
	Condenser blocked with dust	Call your agent or qualified technician
	Doors are not shut properly	Check doors are shut and seals are not damaged
	Appliance is located near a heat source or air flow to the condenser is being interrupted	Move the refrigerator to a more suitable location
	Ambient temperature is too high	Increase ventilation or move appliance to a cooler position
	Unsuitable foodstuffs are being stored in the appliance	Remove any excessive hot foodstuffs or blockages to the fan
	Appliance is overloaded	Reduce the amount of food stored in the appliance
The appliance is leaking water	The appliance is not properly levelled	Adjust the screw feet to level the appliance(If applicable)
	The discharge outside is blocked	Clear the discharge outlet
	Movement of water to the drain is obstructed	Clear the floor of the appliance (if applicable)
	The water container is damaged	Call your agent or qualified technician
	The drip tray is over flowing	Empty the drip tray(if applicable)
The appliance is unusually loud	Loose nut/screw	Check and tighten all nuts and screws
	The appliance has not been installed in a level or stable position	Check installation position and change if necessary

Electrical Wiring

Appliances are supplied with a 3 pin, moulded, BS1363 plug and lead, with a 13 amp fuse as standard. The plug is to be connected to a suitable mains socket. Appliances are wired as follows:

- Live wire (coloured brown) to terminal marked L
- Neutral wire (coloured blue) to terminal marked N
- Earth wire (coloured green/yellow) to terminal marked E

All appliances must be earthed, using a dedicated earthing circuit.

If in doubt consult a qualified electrician.

Electrical isolation points must be kept clear of any obstructions. In the event of any emergency disconnection being required they must be readily accessible.

Disposal

EU regulations require refrigeration product to be disposed of by specialist companies who remove or recycle all gasses, metal and plastic components.

Consult your local waste collection authority regarding disposal of your appliance. Local authorities are not obliged to dispose of commercial refrigeration equipment but may be able to offer advice on how to dispose of the equipment locally.

Compliance

Parts have undergone strict product testing in order to comply with regulatory standards and specification set by international, independent, and federal authorities.

Products have been approved to carry the following symbol:

