

SureSWEEP

STR1800

GB Operating manual

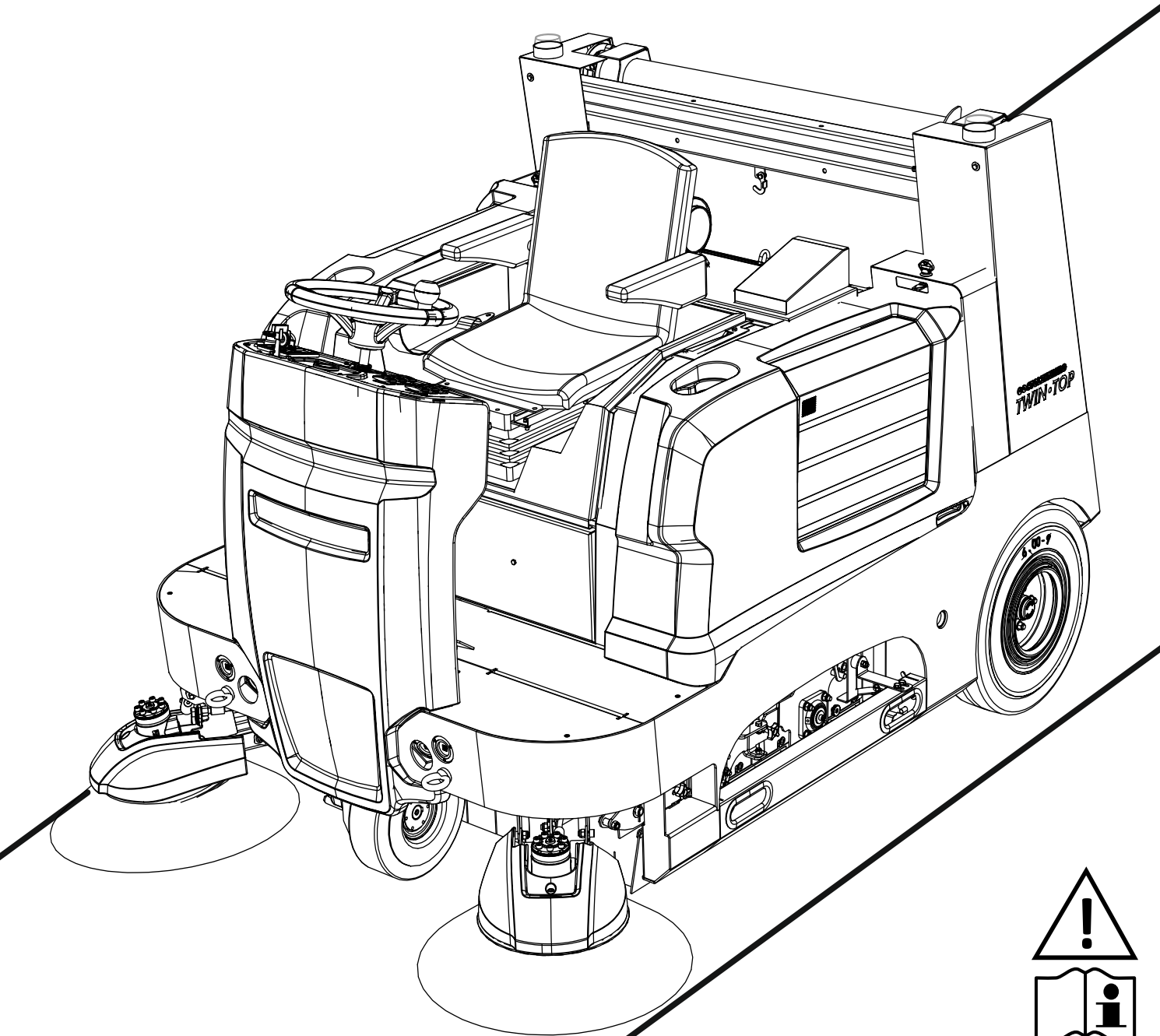

Contents

1	Introduction/Usage conformant with intended purpose	3
2	Safety instructions	3
2.1	General safety instructions	3
2.2	General safety instructions	4
2.3	Symbols in the operating manual	5
2.4	Protective devices	5
3	Environmental protection	5
4	Device description	5
4.1	Function	5
4.2	Technical specifications	6
4.3	Control and functional elements	6
4.3.1	Overview of control and functional elements	6
4.3.2	control panel diesel	7
4.3.3	control panel unit diesel	7
4.3.4	control panel LPG	7
4.3.5	control panel petrol	7
4.3.6	control panel left hand	7
4.4	Unloading the machine	9
4.5	Initial operation	9
4.5.1	Establishing the machine-battery connection	9
4.5.2	Fuel fill	10
4.5.3	Gas cylinder assembly	10
4.5.4	Mounting the side brush	10
5	Operation	11
5.1	Drive system	11
5.1.1	Starting the sweeper unit diesel	11
5.1.2	Starting the sweep LPG/diesel version	11
5.1.2	Drive Modus	12
5.1.3	Parking the sweeper	12
5.2	Sweeping system	13
5.2.1	Sweeping wet materials	13
5.2.2	Height adjustment of the sweeping roller	13
5.2.3	Operation of the sweeper roller drive	13
5.2.4	Dismantling of the Sweeper rollers	14
5.2.5	Installation of the Sweeper rollers	16
5.2.6	Height adjustment of the side brush	16
5.2.7	Operation of the side brush drive	17
5.2.8	Dismantling the side brush	17
5.2.9	Installation of the side brush	18
5.3	Dust suction	18
5.3.1	Operation of the fan	18
5.3.2	Operation of the Filter vibrator	18
5.3.3	Dismantling the filter	18
5.3.4	Installation of the filter	19
5.3.5	Filter cleaning	20
5.4	High-dumping system	20
5.4.1	Operation of the high-dumping system	20
5.4.1	Cleaning the refuse container	21
5.4.2	Maintenance support	21
5.5	Fuse box	22
6	Cleaning and maintenance	22
6.1	Safety instructions for cleaning and maintenance	22
6.2	General cleaning and maintenance instructions	22
7	Faults, fault indications and remedy	24
8	Maintenance intervals	25
8.1	daily maintenance instructions	25
8.2	Additionally every 50 operating hours	25
8.3	Additionally every 100 operating hours	25
9	Nameplate	25
10	Accessories and spare parts	25
11	Warranty	25
12	Transport of the sweeper	26
13	EC Declaration of Conformity	27

1 Introduction/Intended use

This operating manual contain instructions for using the sweeper.

Our products are subject to continuous improvement. Therefore, design changes that were made after this manual went to print could not be incorporated.
If you have any questions, please contact our Service department.

The operating manual must be read and applied by all persons who operate the sweeper.

Apart from the operating manual and the regulations for accident prevention applicable in the country of use and the location of use, the common, recognised rules for safe and technically correct working must also be followed.

The appliance is intended exclusively for sweeping on solid surfaces (for example.: parking areas, walkways, shop floors).
The area to be swept should not be wet.

The sweeper may only be used by reliable and instructed personnel.

Prevent use by children, teenagers and other unauthorized persons, e.g. by removing the key after use.

Any other or additional use is considered to be improper (see. safety instructions Ch.). The manufacturer shall not be liable for resulting damages.

The operator is solely responsible for the risk.

Intended use also includes compliance with the operating manual, the safety instructions and the inspection and maintenance requirements.

Only drive on routes and places that have been expressly assigned.

Notes on appropriate surfaces (asphalt, screed, industrial flooring, concrete, paving stones, carpets, artificial grass, etc.)

2 Safety instructions

2.1 General safety instructions













- Only use the machine in perfect condition and as intended, while being aware of safety and dangers, and in compliance with this operating manual!
- The machine does not have road use homologation.
- In addition to the operating manual, also note the generally applicable statutory and other binding regulations relating to accident prevention and environmental protection!
- It is forbidden to sweep flammable, toxic or explosive substances, as well as flammable gases or undiluted acids and solvents, burning or smouldering objects!

- The device is not suitable for holding liquids, ropes, twine, wire or the like.
- Use the machine exclusively with the hopper inserted, to prevent injuries from flying parts.
- The transport of loads with the sweeper is not permissible.
- Faults, in particular those that may impair safety, must be remedied immediately!
- Do not perform any modifications, additions or conversions on the machine without approval from the manufacturer.
- Spare parts must meet the requirements defined by the manufacturer. This is always guaranteed with original spare parts.
- Accessories and spare parts may only be installed by an authorized service centre.
- Ensure a safe and environmentally friendly disposal of operating and auxiliary materials as well as replaced parts, especially the batteries!
- Suitable, non-slip footwear must be worn to avoid accidents.
- Persons (including children) who, due to their physical, sensory or mental abilities or their inexperience or ignorance, are not able to use the machine safely, may not use this machine without supervision or instruction by a responsible person! Children should be supervised to ensure they do not play with the machine.
- Caution: Loose clothing may be drawn-in by rotating parts.
- The operating instructions of the battery manufacturer for his product, as well as the specifications of the legislator for the handling of rechargeable batteries must be observed!
- Please observe the fact that the accumulators are filled with battery acid!
- Always keep the batteries clean and dry, in order to prevent leakage currents! Never short-circuit the battery terminals!
- If you need to charge the battery, only charge it in well-ventilated rooms and using a charger that is approved by the manufacturer. Keep it away from naked flames and electrical sparks.
- Smoking, eating and drinking must be avoided in the area around the battery charging station must be avoided to prevent damage to health.
- Observe the maximum gradient and maximum possible oblique inclination specified in the technical data when driving along a slope. Abrupt or excessive steering, especially on slopes, may cause the machine to tip over. Adapt your driving style and speed to the circumstances.
- Never reach under the machine while it is running (danger of entanglement).
- In areas which are susceptible to dust, always switch on the dust extractor, shake regularly and wear a breathing mask.
- Always disconnect the battery when carrying out maintenance work or replacing components. Wear a face mask and gloves while you are doing this and ensure that the machine cannot roll away (chocks).
- Do not use the machine in the rain and do not clean it with (a) water (jet).
- When the machine is parked (especially on slopes), it must be secured with the chocks.
- In the event of a fault message (red indicator light comes on), switch off the machine immediately and diagnose the fault.
- Ensure that sufficient breaks are taken during use.
- The interior of the machine must only be accessible to trained specialist personnel. This is ensured by a separate key. This may only be given to personnel who have received training in this.
- The machine may never be used without dust filters or other attachments.

2.2 Symbols on the device

	READ THE OPERATING MANUAL!
	WARNING: HOT SURFACES!
	WARNING: RISK OF HAND INJURIES!

2.3 Symbols in the operating manual

	WARNING! ATTENTION! DO NOT TRANSPORT BY FORKLIFTRUCK!
	WARNING! ATTENTION! DANGER! THE DESCRIBED INSTRUCTIONS MUST BE OBSERVED!
	WARNING: RISK OF HAND INJURIES!
	WARNING: POTENTIALLY FLAMMABLE SUBSTANCES!
	WARNING: ELECTRICAL VOLTAGE!
	WARNING: HOT SURFACES!
	WARNING: GAS CYLINDERS!
	WEAR PROTECTIVE GOGGLES!
	USE A RETENTION SYSTEM
	WEAR PROTECTIVE GOGGLES!
	USE PROTECTIVE FOOTWEAR
	WEAR GLOVES

2.4 Safety Devices

The sweeper can only be started if...

- the operator is seated in the driver's seat.
- the start key is turned clockwise.
- the emergency stop switch is not operated.

The tipping function of the dust container can only be operated if the dust container is almost extended.

The high-dumping system must be fixed by a mechanical support during maintenance work when the high-dumping system is extended.

All protective devices of the machine must not be bridged or put out of service!

3 Environmental protection.

Recycling of packaging materials. Do not dispose packaging materials in the household rubbish and recycle it instead. Used devices contain valuable recyclable materials which should be salvaged for recycling. Batteries, oil and similar substances may not be released into the environment. Please dispose used devices in suitable collection systems.

4 Device description

4.1 Function

The TT1800 is a sweeper with a fully hydraulic drive system driven by a combustion engine, which is equipped with the tandem roller sweeping system. It is equipped with an automatically lowering sweeping roller and a powerful dust extractor.

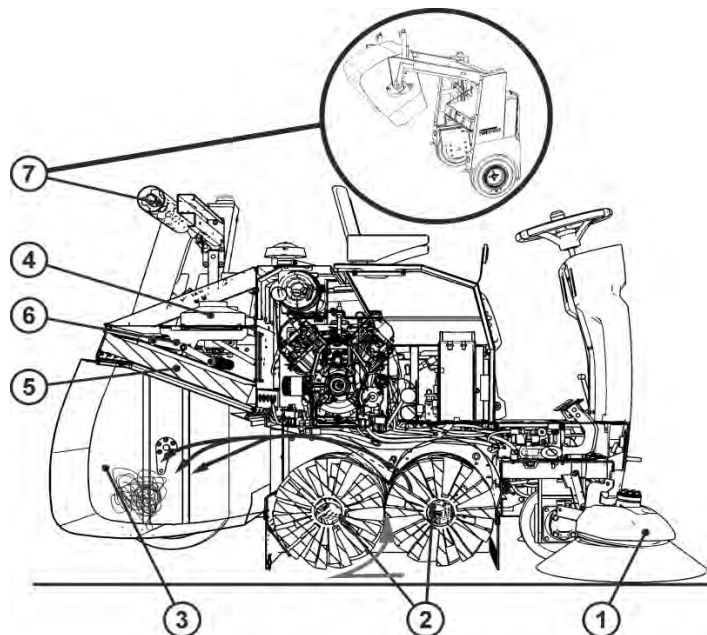

In the TRS-Flex system, the sweeping rollers adapt to the unevenness of the ground. The dirt is first transported by the side brushes (1) from the corners and edges of the sweeping area to the centre of the machine and thus to the two sweeping rollers (2) rotating against each other. The dirt is picked up by them and transported to the refuse container (3) behind them. The dust that is whirled up by the sweeping process is sucked in by two fans (4), filtered through a flat-pleated filter (5) and thereby separated from the clean air. A cleaning system (6) releases the dust cake adhering to the lamella filter and drops it into the refuse container. The refuse container is emptied with the high-dumping system (7).

4.2 Technical specifications

DEVICE SPECIFICATIONS

Model: TT1800D	
Combustion engine	Kohler KDW1003 3-Cylinder water-cooled 19,5KW/ 26,1PS 3600U/Min
Length / Width / Height	[mm] 2095/1145/1520
Net weight	[kg] 1110
Transport weight	[kg] 1205
Permissible total weight	[kg] 1600
consumption (Information manufacturer)	[l/h] 4,3
Runtime (calculated)	[h] 2,3
Modell: TT1800LPG	
Combustion engine	Kubota DF752 3-Cylinder water- cooled 17,5KW/ 23,8PS 3600U/Min
Length / Width / Height	[mm] 2095/1145/1555
Net weight	[kg] 1035
Transport weight	[kg] 1130
Permissible total weight	[kg] 1600
Consumption (Information manufacturer)	[kg/h] 3,89
Runtime (calculated 11kg-gas cylinder)[h]	2,8
Modell: TT1800 petrol	
Combustion engine	Kohler ELH 775 2-V-Cylinder water-cooled 22,4KW/ 30PS 3600U/Min
Length / Width / Height	[mm] 2095/1145/1520
Net weight	[kg] 1050
Transport weight	[kg] 1145
Permissible total weight	[kg] 1600
consumption (Information manufacturer)	[l/h] 4,8
Runtime (calculated)	[h] 2,08
DRIVING CHARACTERISTICS	
Speed	[km/h] 10
Turning radius	[m] 1,55
Max. gradient.	[%] 20
SWEEPING PROPERTIES TRS-Flex-System	
Sweeping width without sidebrush	[mm] 1000
Sweeping width with 1 side brush[mm]	1400
Sweeping width with 2 side brushes	[mm] 1800
Hopper volume	[l] 380
Filter type	[-] Flat-fold filter
Filter area	[m ²] 8,8
Net cleaning surface	[m ²] 125.000

ELECTRICAL PROPERTIES

Total current consumption	[V]	12
Battery	[-]	Battery Eternity 12V 75Ah (C20) acid

Emissionen

Sound pressure level	LWA[dB]	100
----------------------	---------	-----

4.3 Control and functional elements

4.3.1 Overview of control and functional elements

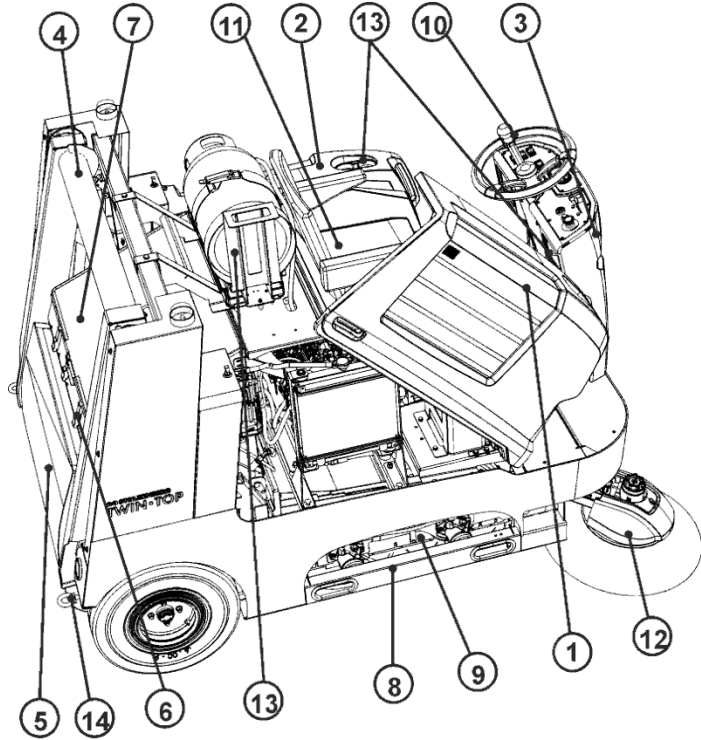

- | | |
|-----------------------|---|
| 1 Right side fairing | 8 Fender |
| 2 Left side fairing | 9 Sweep roller system |
| 3 Front fairing | 10 Steering wheel |
| 4 High-dumping system | 11 Driver's seat |
| 5 Dust container | 12 Side brush |
| 6 Rain flap locks | 13 Gas cylinder holder
and filter box cover
(LPG version) |
| 7 Filter system | 14 Towing lugs |

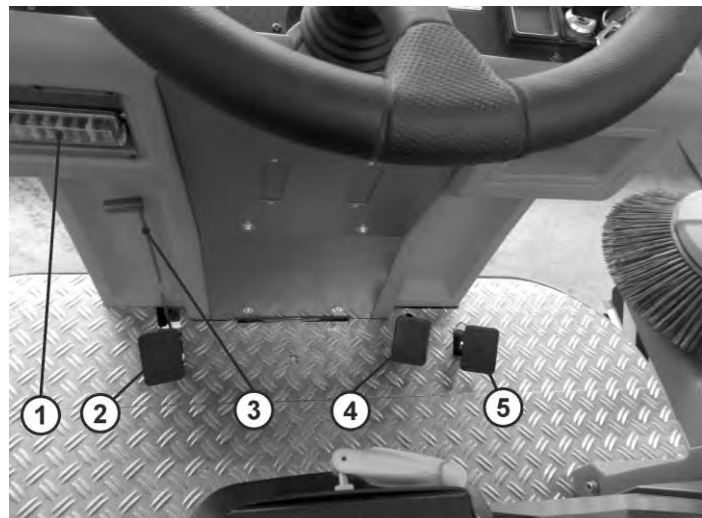

- | |
|-----------------|
| 1 Fuse box |
| 2 Brake pedal |
| 3 Parking brake |
| 4 Reverse pedal |
| 5 Forward pedal |

4.3.2 Control panel unit diesel



- 1
- 2
- 3
- 4
- 5

- 1 Level indicator
- 2 Gas lever
- 3 Control panel unit diesel
- 4 Emergency stop switch
- 5 Horn

- 1 Elapsed-hour meter
- 2 Coolant temperature indicator light
- 3 Generator indicator light (charge voltage)
- 4 Ignition switch
- 5 Gas lever
- 6 Horn
- 7 Emergency stop switch

4.3.5 Control panel unit petrol



- 1
- 2
- 3
- 4
- 5
- 6
- 7

- 1 Elapsed-hour meter
- 2 Level indicator
- 3 Generator indicator light (charge voltage)
- 4 Ignition switch
- 5 Gas lever
- 6 Horn
- 7 Emergency stop switch

4.3.3 Control panel unit diesel

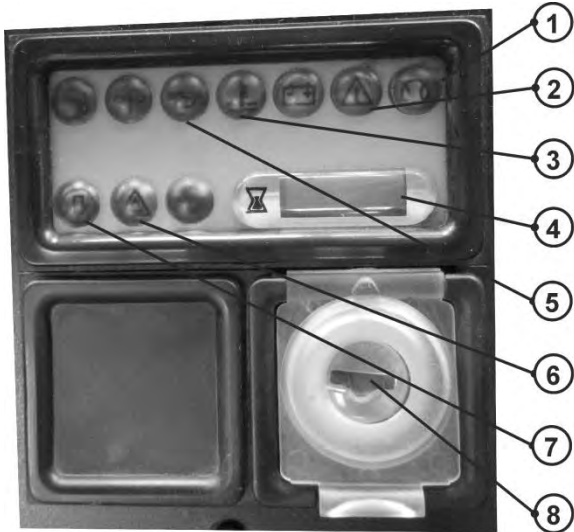

- 1
- 2
- 3
- 4
- 5
- 6
- 7
- 8

- Note: Some indicator lamps not working
- 1 Preheating indicator lamp
 - 2 Warning lamp
 - 3 Oil overheating
 - 4 Elapsed-hour meter
 - 5 Oil pressure indicator lamp
 - 6 Warning lamp
 - 7 Obstruction indicator lamp
 - 8 Ignition switch

4.3.6 Control panel left side (all engine versions)

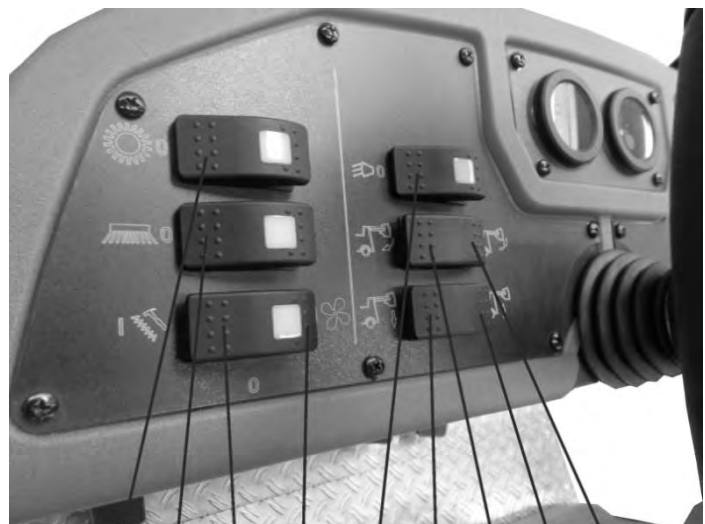

- 1
- 2
- 3
- 4
- 5
- 6
- 7
- 8
- 9

- 1 Sweeping roller ON/OFF
- 2 Side brush ON/OFF
- 3 Vibrator ON
- 4 Fan ON
- 5 Front light ON/OFF
- 6 Retract high-dumping system
- 7 Retract dust container
- 8 Extend high-dumping system
- 9 Tip out dust container

4.3.4 Control panel LPG version



- 1
- 2
- 3
- 4
- 5
- 6
- 7

4.4 Unloading the machine



WARNING! - The sweeper must not be unloaded from the pallet using a forklift truck! This will result in damage to the machine! This increases the risk of injury from tipping loads! Drive carefully down the ramp. Damage to the machine can be avoided by a 2nd person.

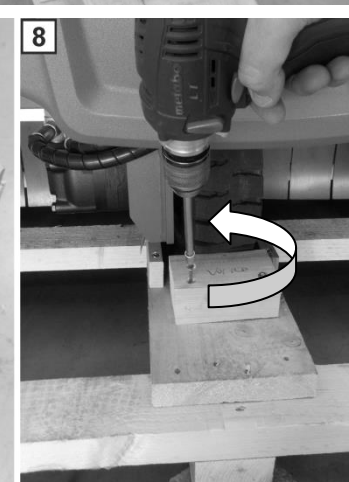
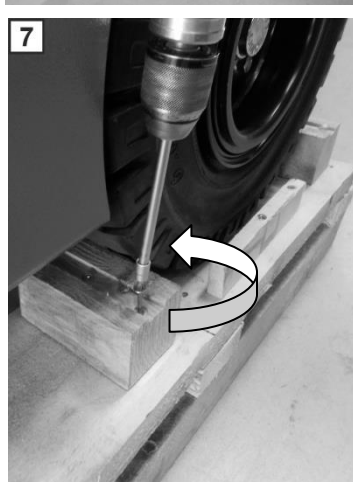
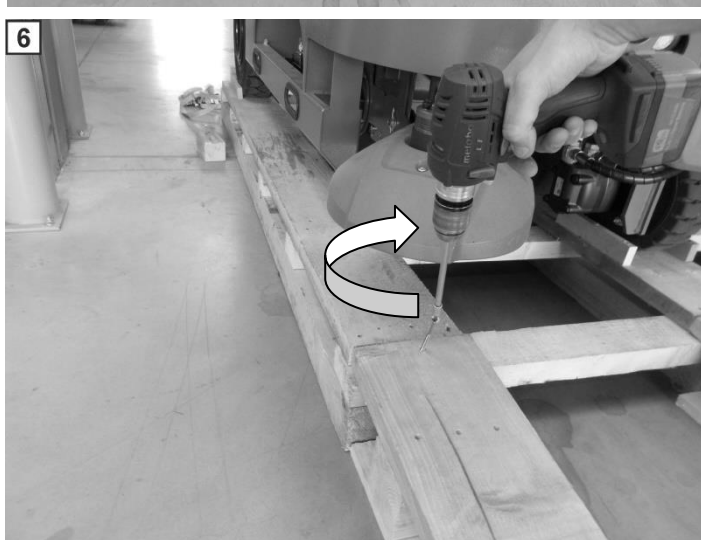
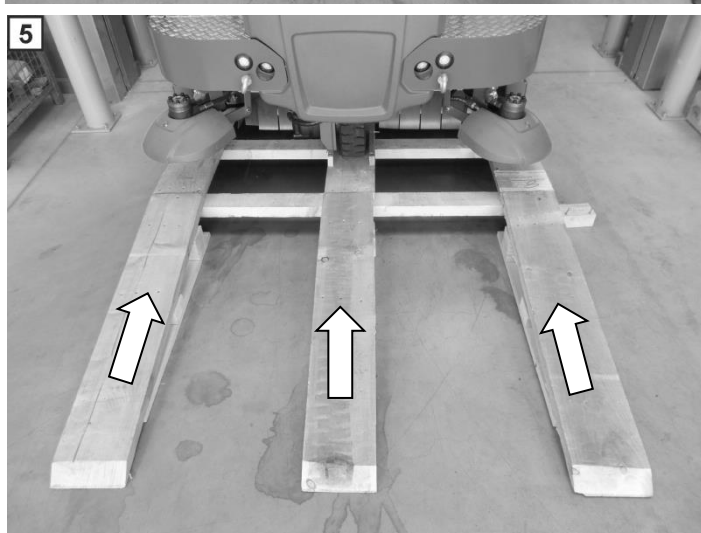
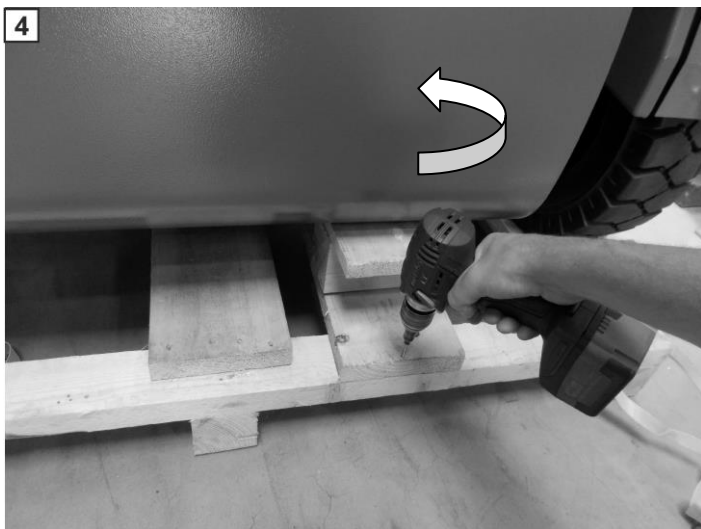
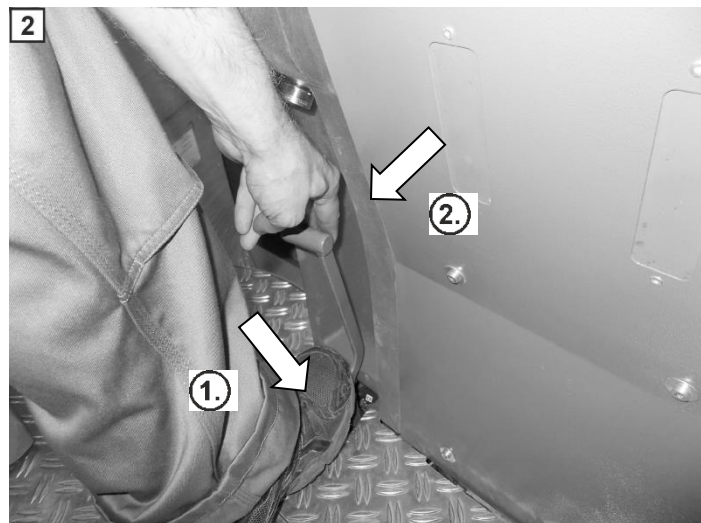
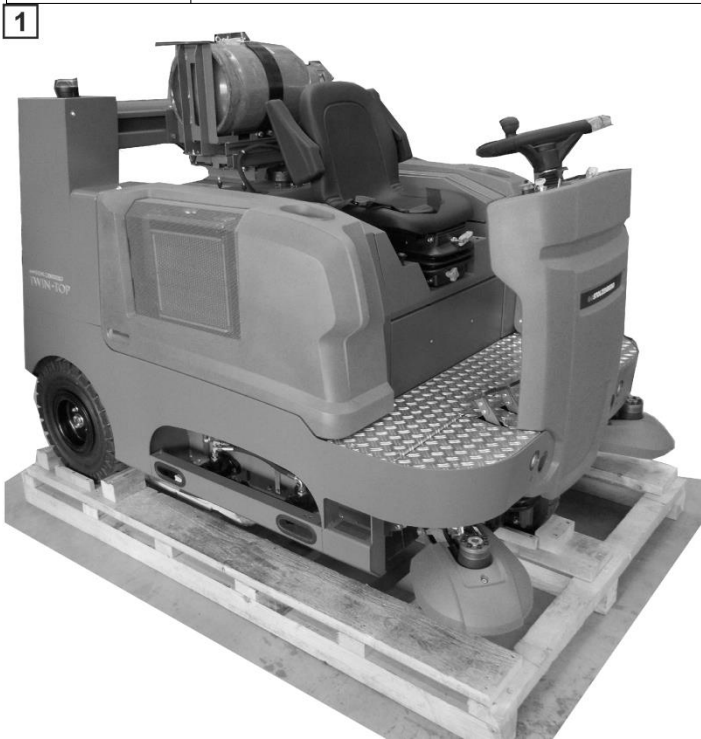



- 9 Establishing the machine-battery connection
- 10 Fuel fill
- 11 Gas cylinder assembly
- 12 Mounting the side brush

- ➡ Page 9; 4.5.1
- ➡ Page 10; 4.5.2
- ➡ Page 10 ; 4.5.3
- ➡ Page 10; 4.5.4

4.5 Initial operation

4.5.1 Establishing the machine-battery connection

WARNING! – Wear protective gloves when working around the battery to avoid injury.

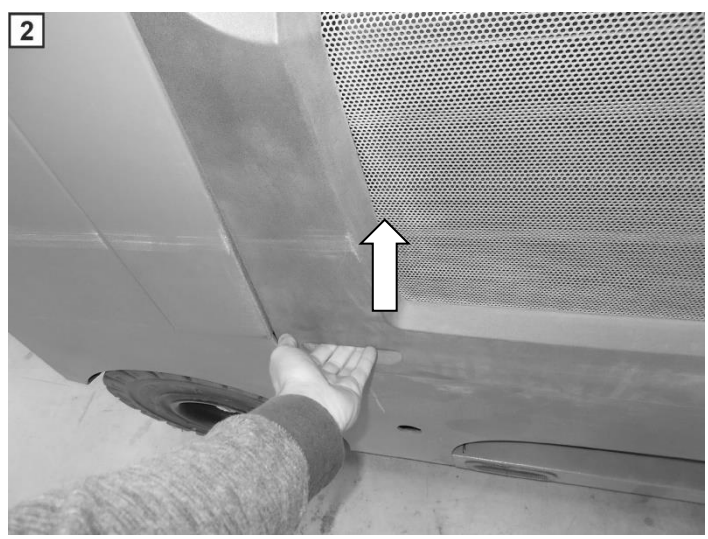
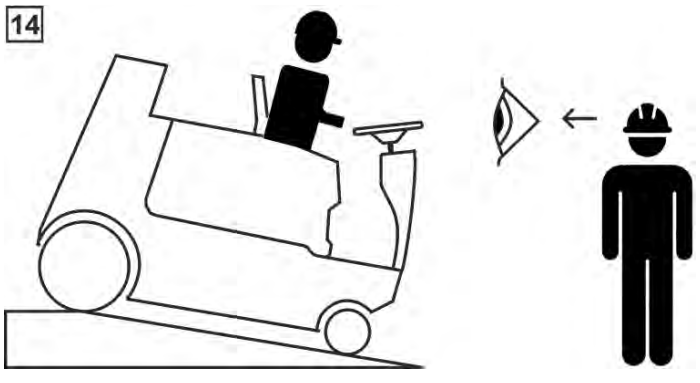
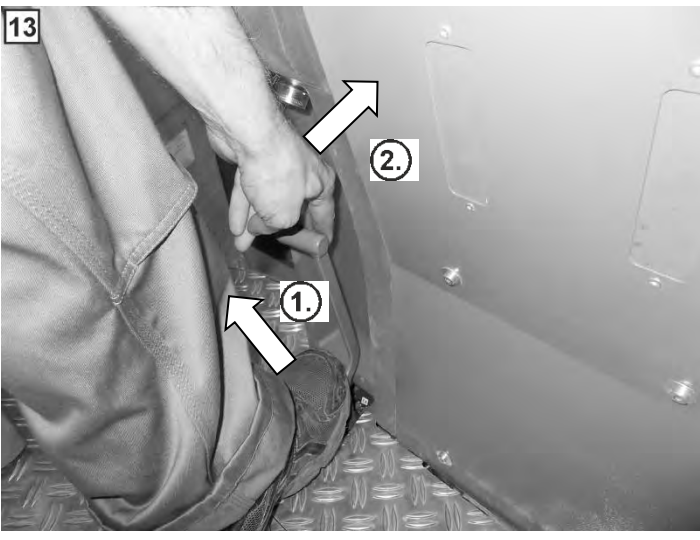

4.5.2 Fuel fill



WARNING! – Caution: flammable substances. Wear protective gloves, a face mask and goggles when filling. Only fill the fuels specified for your engine version.



4.5.3 Gas cylinder assembly



WARNING! – The gas cylinder may only be connected by qualified personnel! Take care when using the assembly aid. There is a risk of hand injuries if the device is not handled properly.

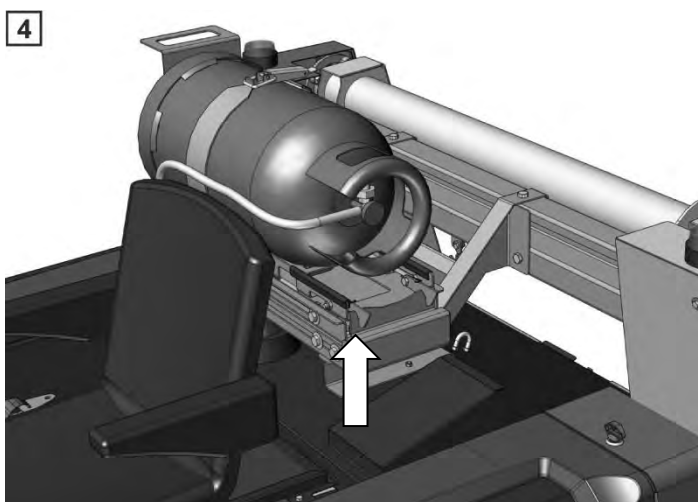
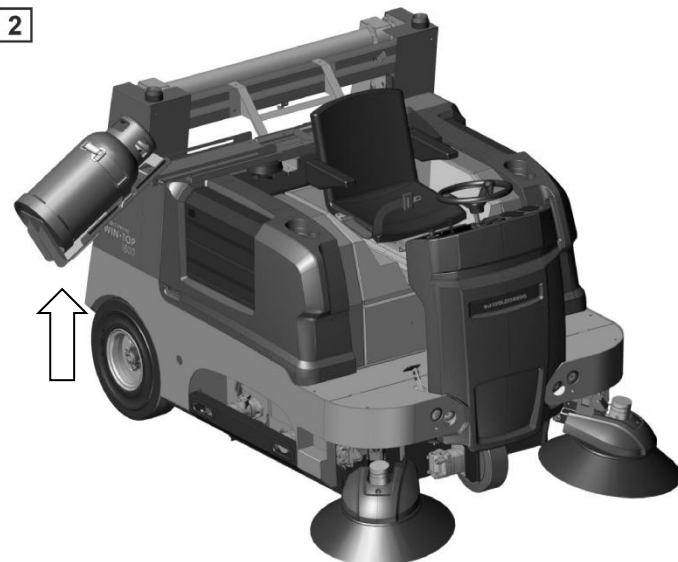

1 - 4 : Attach the gas cylinder and fasten with a lashing strap. Ensure that the assembly aid engages securely. Ensure that the gas hoses are not damaged. This is an explanation for the deluxe version. In the standard version, the gas cylinder must be securely mounted on the holder. Movement (**1 - 3**) is not possible here.

4.5.4 Attaching the side brushes



1 : Remove the cable tie and watch for loose parts.

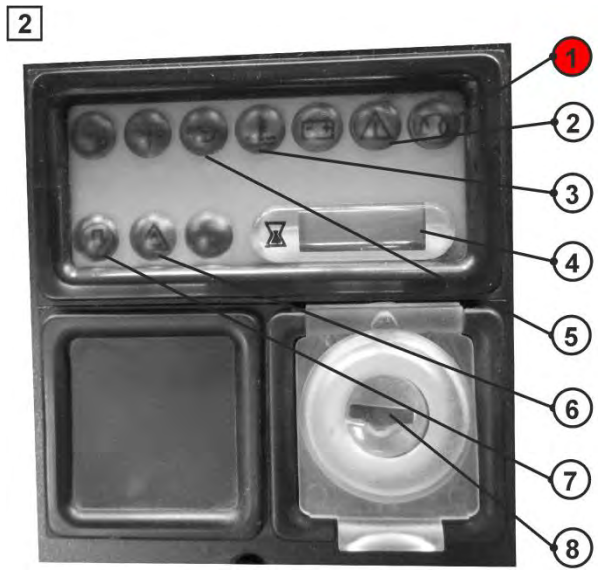
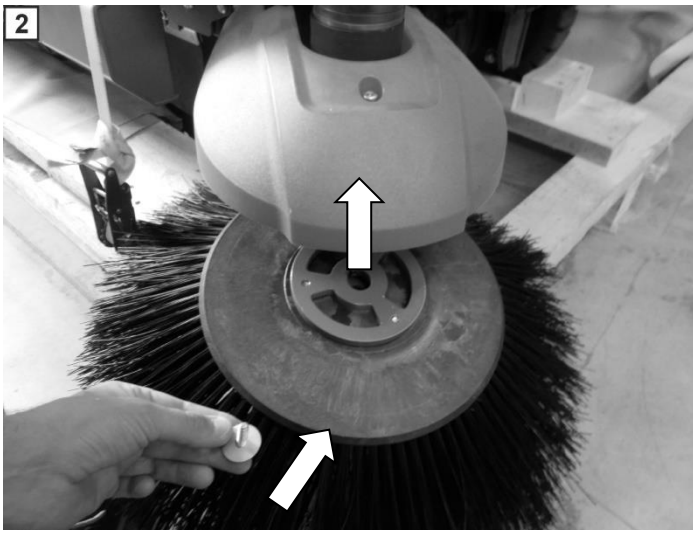

5 Operation

5.1 Drive system

Your sweeper is equipped with a combustion engine. We recommend using the machine only in well-ventilated rooms. The combustion engines must be retracted during initial commissioning. The power consumption in the first 50 hours in service must not exceed 70% of the full load power.



ATTENTION! – Seat belts must always be used during operation.

5.1.1 Starting the machine unit diesel



Check all fluid levels before starting. Insert the key into the ignition switch to start the engine. Turn the key clockwise until it audibly engages. The signal lamps of the control panel light up now. The "preheating" indicator lamp (**2** **1**) means that the engine combustion chamber is preheated to ensure a smooth start. Please wait until the indicator lamp goes off. Once it goes off, you can start the engine by turning the key further clockwise. Do not press the drive pedals. After starting, release the ignition key.

5.1.2 Starting the sweep LPG/Petrol version



Before starting, open the shut-off valve on the gas cylinder (LPG version only) and check all fluid levels. Insert the key into the ignition switch (**1**). to start the engine. Turn the key clockwise to position "0" (**2**) to switch on the ignition. Turn the ignition key further towards "Start" (**2**), to start the engine. After starting, release this. Do not press the drive pedals.

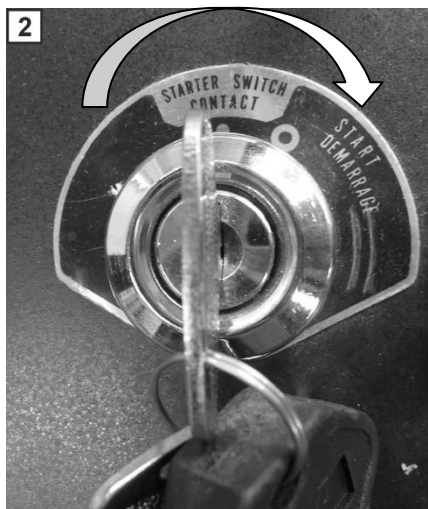

5.1.2 Drive System

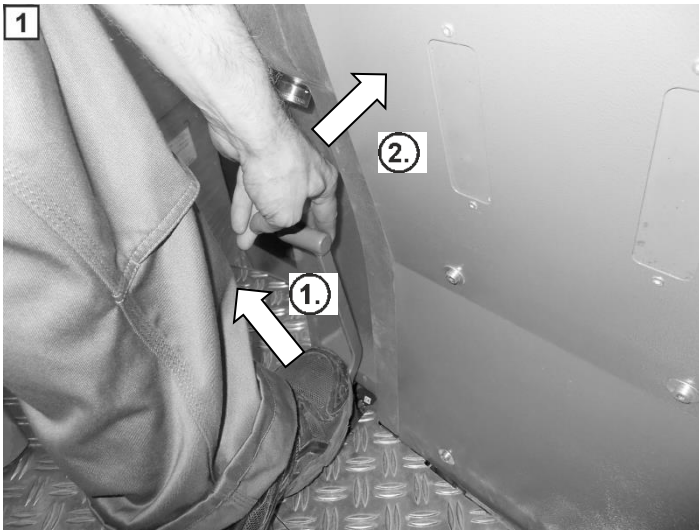

Ensure that the parking brake is released. Do not apply the brake while driving.

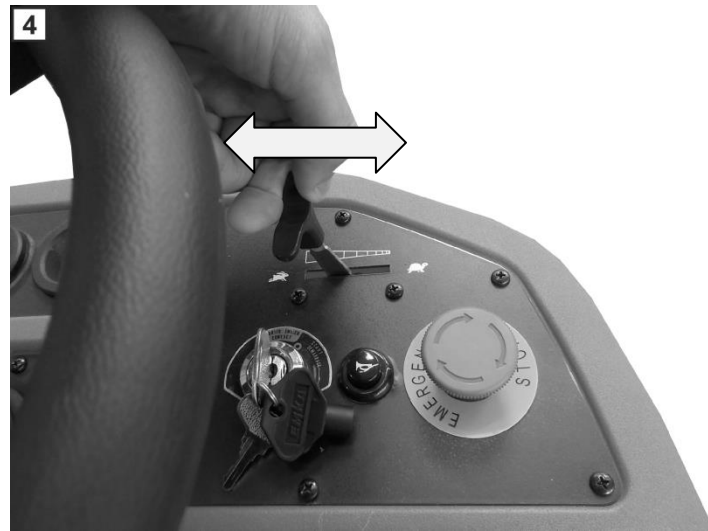

Regulate the rpm of the engine by using the throttle lever.

5.1.3 Parking the sweeper

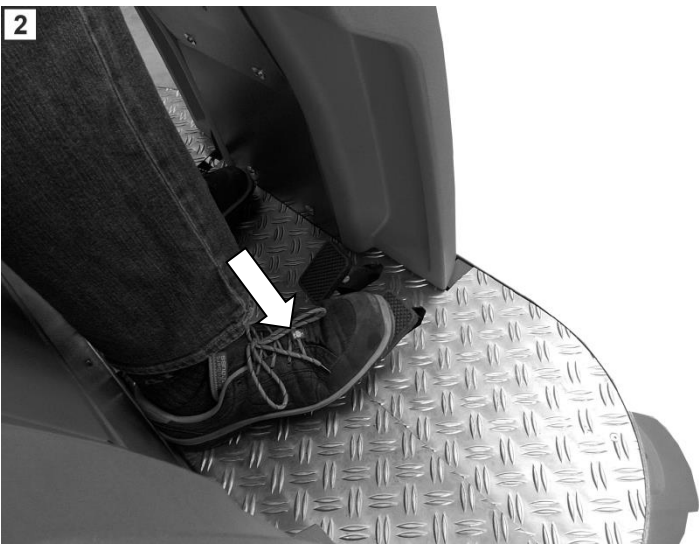

The machine advances by pressing the right-hand drive pedal.

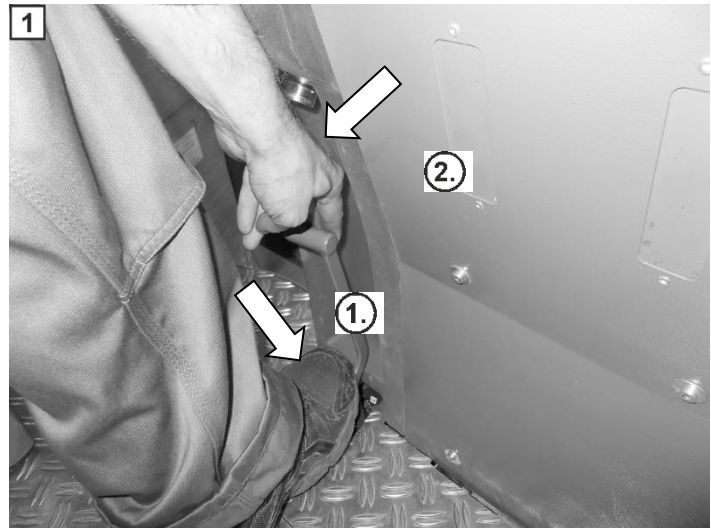

Park the machine on dry and level ground (without slope). Apply the parking brake (**1**). Secure the machine additionally with chocks (**2** - **3**). They can be found inside the machine.

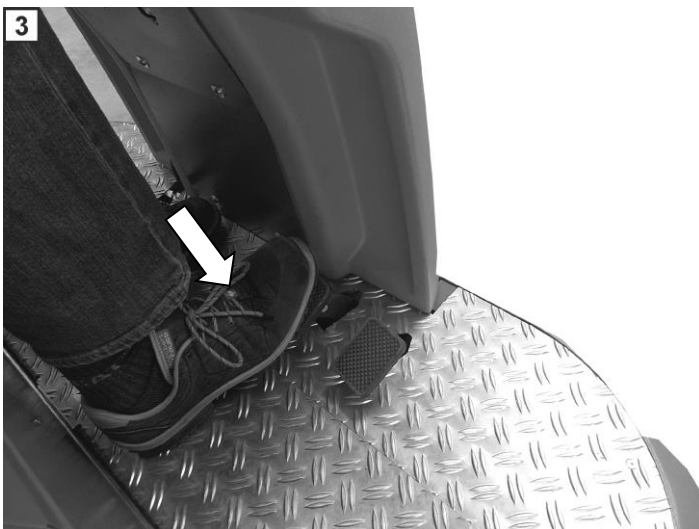

The machine reverses by pressing the left-hand drive pedal.

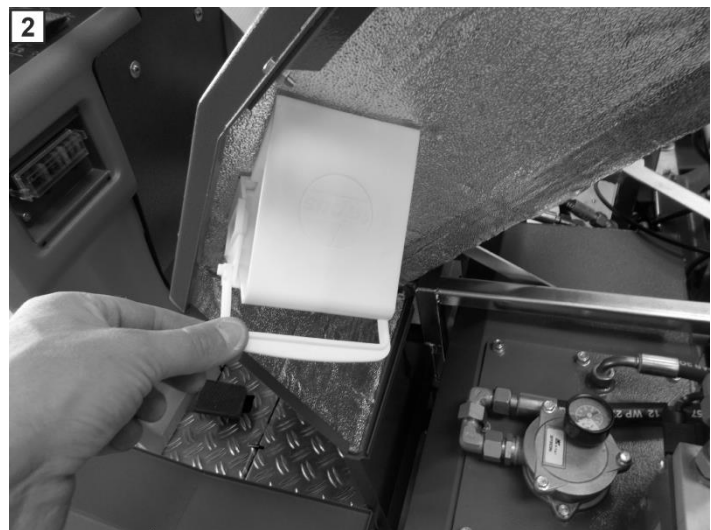

5.2 Sweeping system

5.2.1 Sweeping wet materials



ATTENTION! – Switch off the fan when sweeping wet refuse. This possibly will cause damage to the the dust filter!

5.2.2 Height adjustment of the sweeping rollers

Your sweeper is equipped with the Tandem Roller Flex System (TRS-Flex) and automatic lowering of the sweeping roller. The sweeping rollers adapt to the ground, which means there is no need for height adjustment. Nevertheless, this may become necessary if the rollers are worn or adjusted to a certain maximum sweeping pattern. Lift up the left side door first. You can raise or lower the max. low point by turning the adjusting screw (**1**). Only adjust this when the machine is switched off.

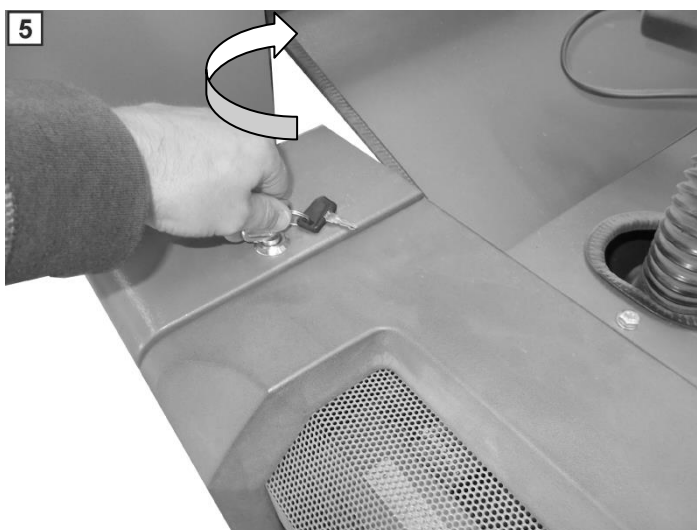
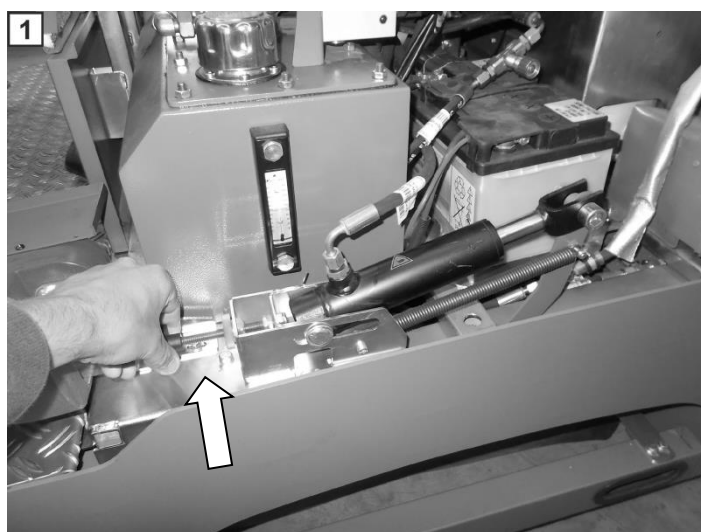
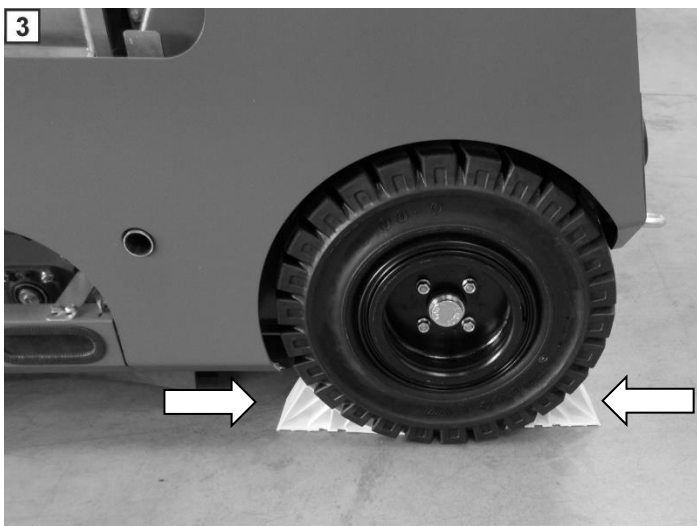

5.2.3 Operation of the sweeper roller drive



ATTENTION! – Always wear face masks and seat belts when sweeping.



After parking the machine, remove the ignition key and lock the side doors with the workshop key to prevent unauthorised access. (**4** · **5**).

Press the switch to set the sweeping rollers to position I. The sweeping rollers can be operated separately from the operation of the side brush. The engine must be running for operation.

5.2.4 Dismantling of the Sweeper rollers



ATTENTION! – Always wear gloves, goggles and a face mask during assembly.

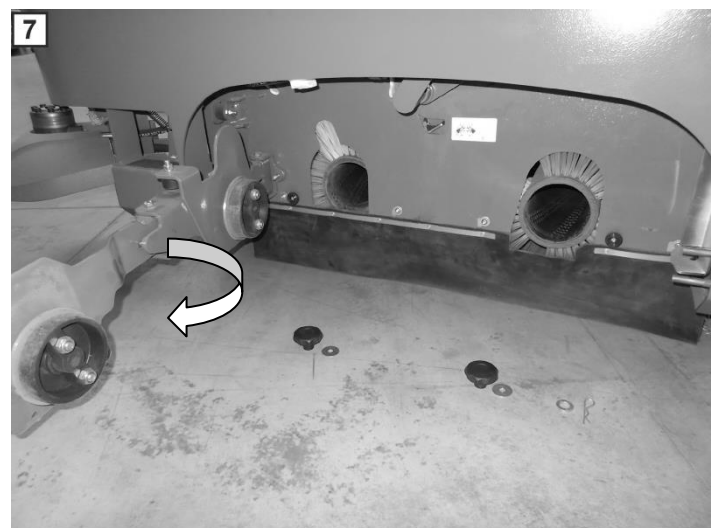
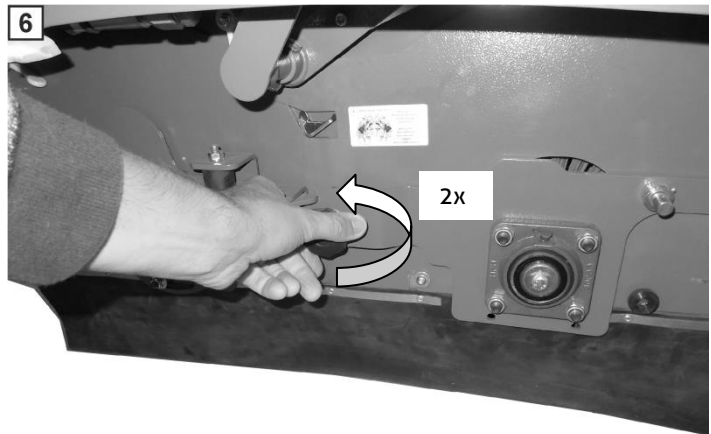
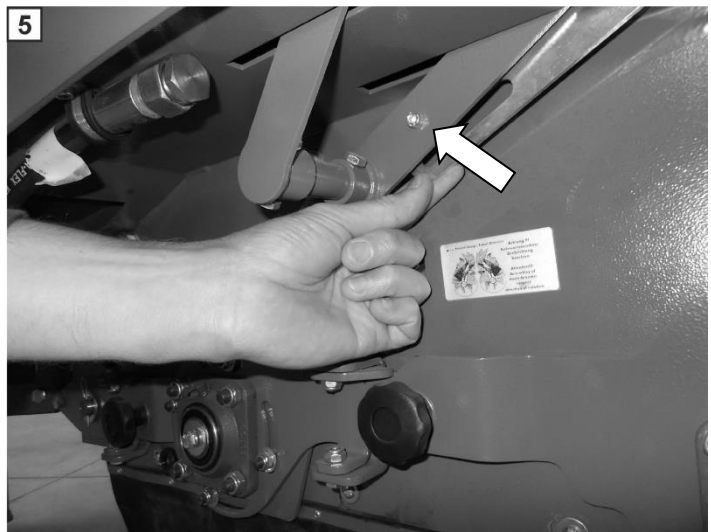
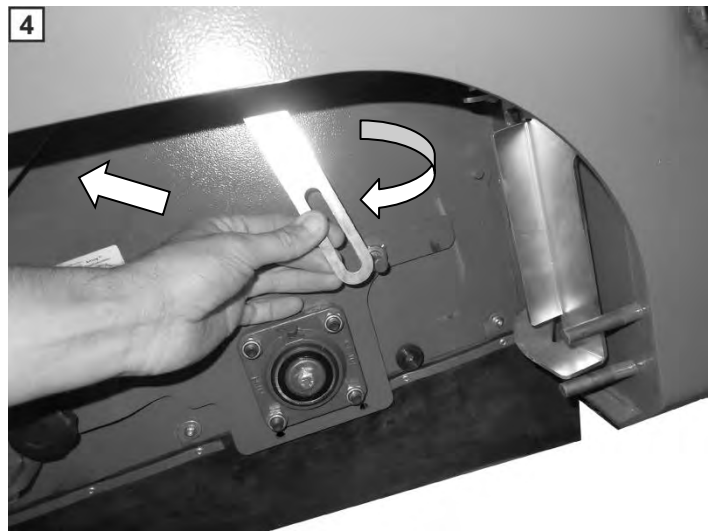
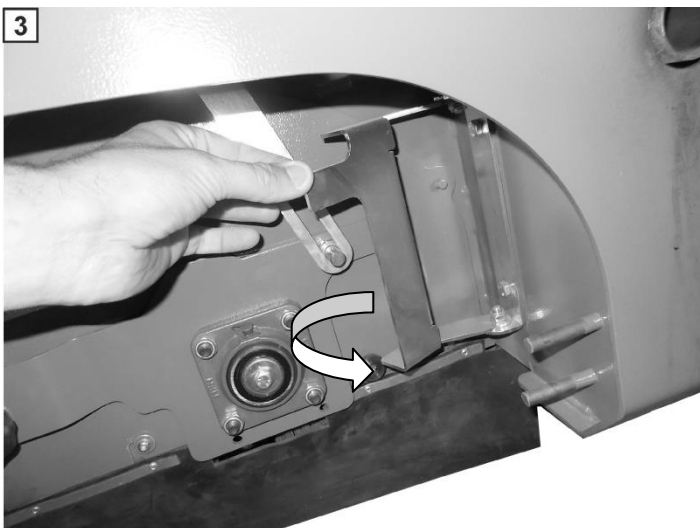
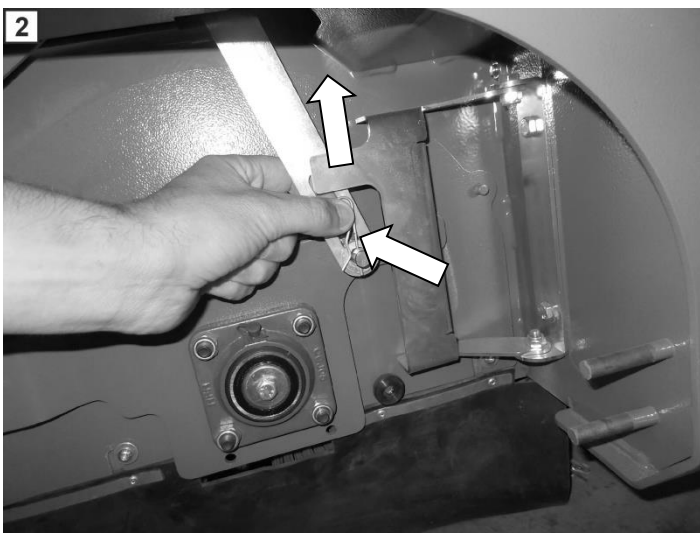
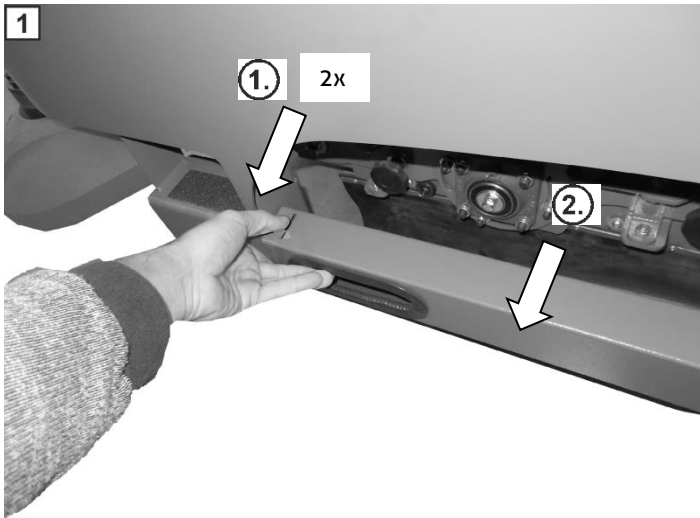

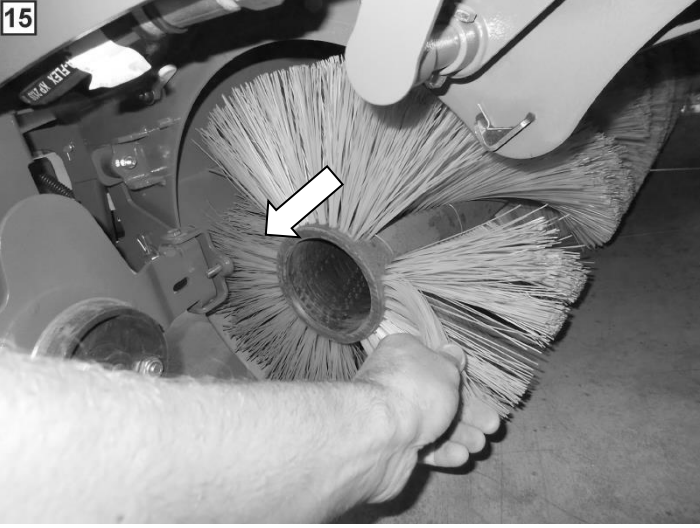
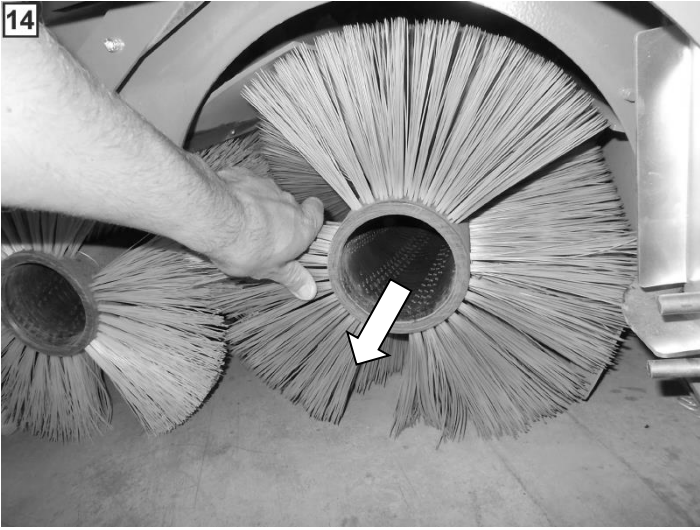
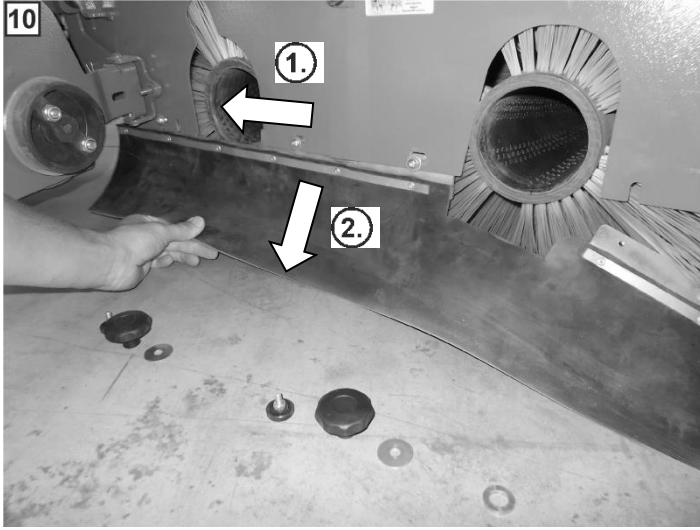
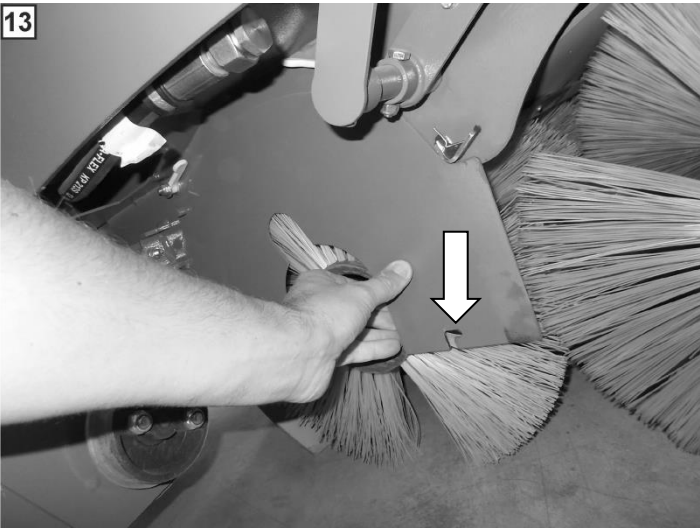
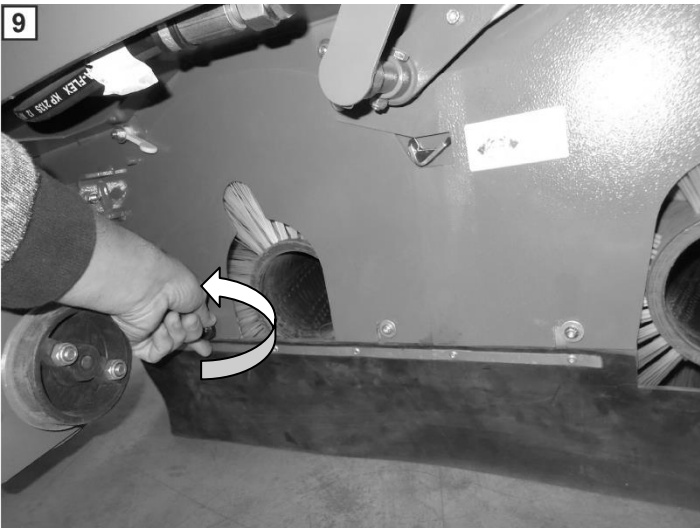
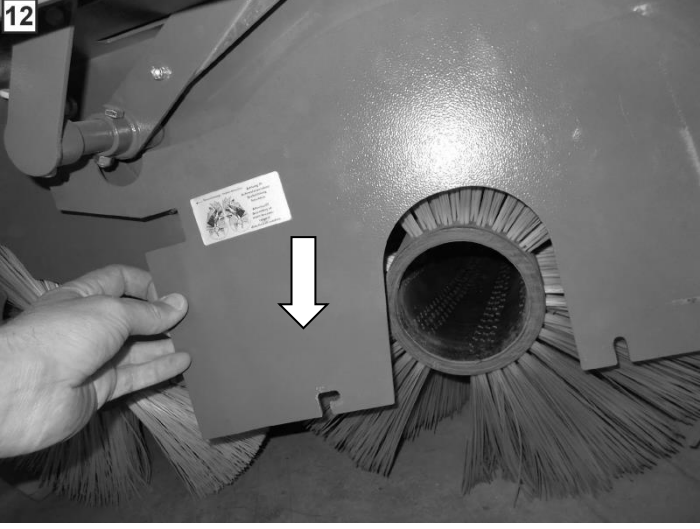

5.2.5 Installation of the Sweeper rollers



ATTENTION! – Always wear gloves, goggles and a face mask during assembly. Ensure that the sweeping rollers are installed in the correct direction! (**1**)

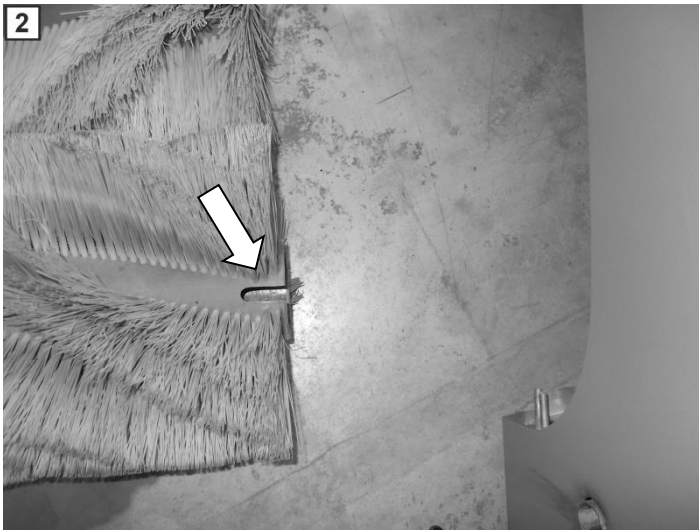
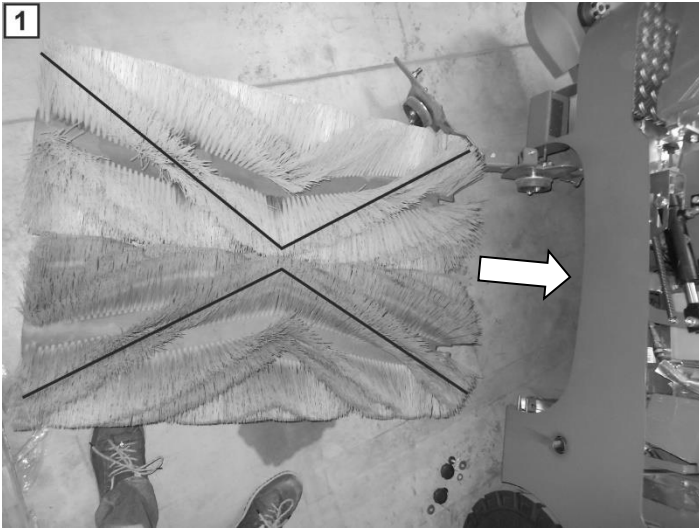

The slots of the sweeping roller (**2**) must be guided onto drivers (**3**). A torch may be a useful aid here (**4**).

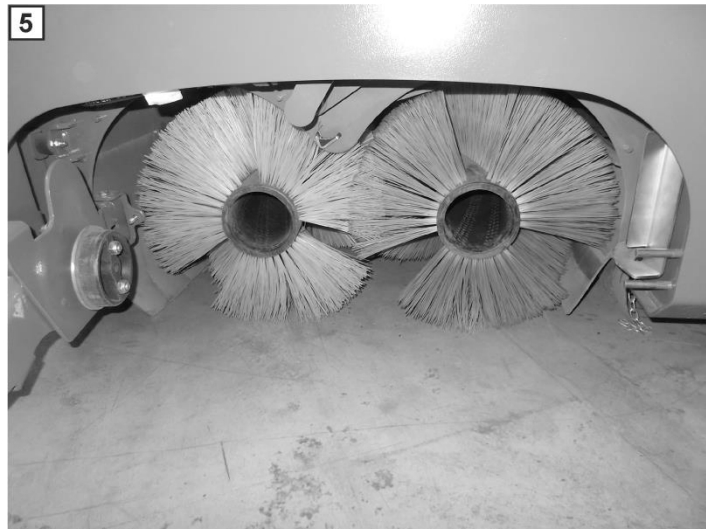
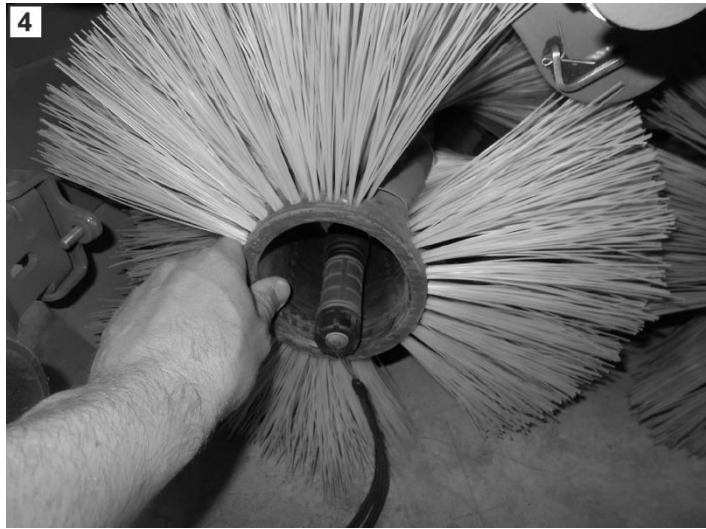

After installing the sweeping rollers, carry out the steps in chapter 5.2.4 in reverse order.

5.2.6 Height adjustment of the side brush

You can adjust the height of the side brush. By loosening the screw connection (**2**) you can adjust the height of the side brush in several steps using the eccentric. After adjustment, retighten the screw connection. After loosening several times, please replace the screw connection.

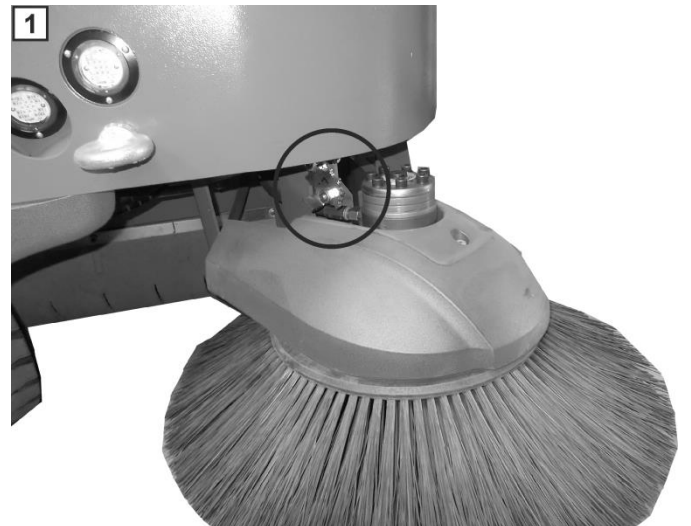

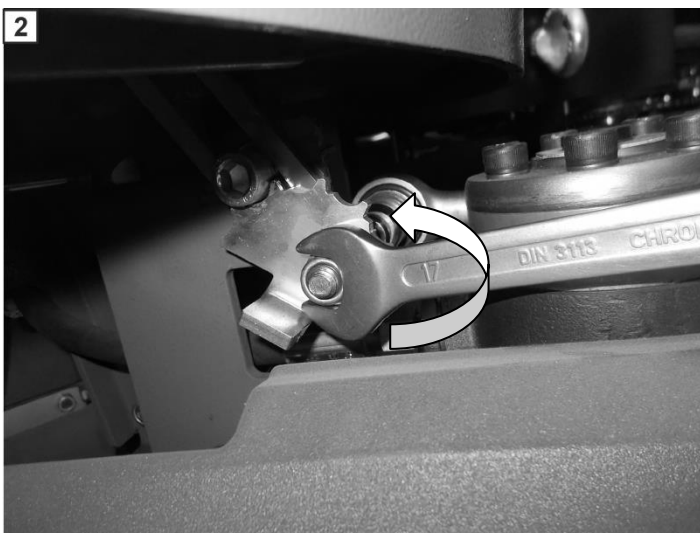

5.2.7 Operation of the side brush drive

		<p>ATTENTION! – Always wear a face mask and seat belt when sweeping.</p>



Press the switch to set the side brush to position I. The side brush can be operated separately from the operation of the sweeping rollers. The side brush retracts automatically when switched on. The engine must be running for operation. Turn the switch to the 0 position to switch it off.

5.2.8 Dismantling the side brush

		<p>ATTENTION! – Wear gloves, goggles and a face mask during assembly. Loose parts must be secured.</p>

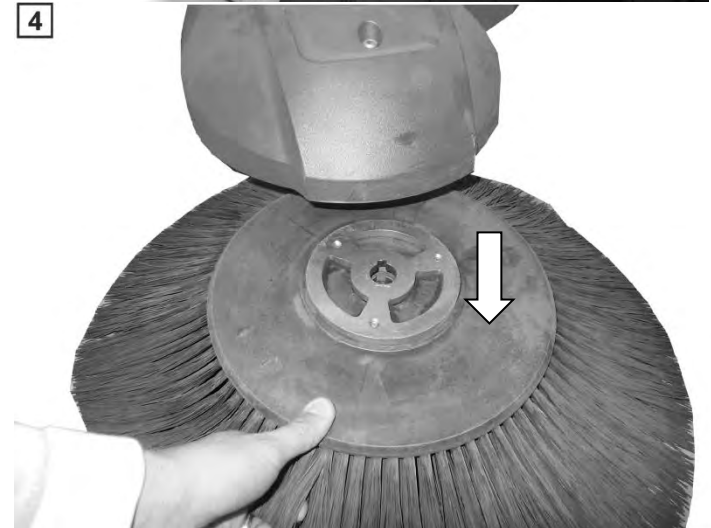
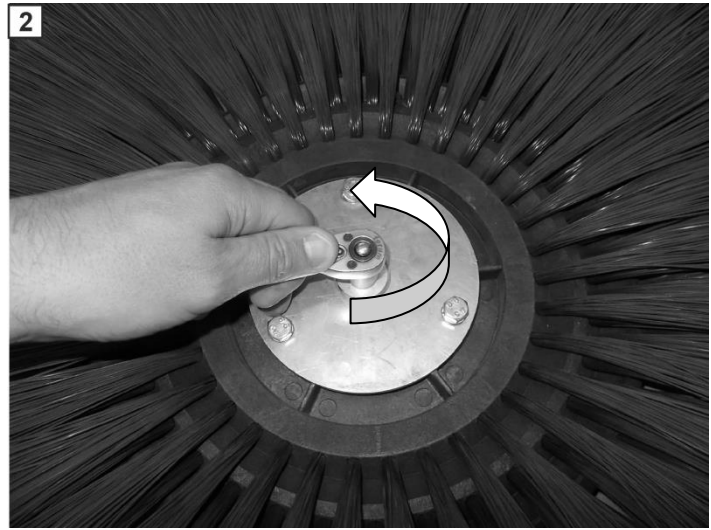

5.2.9 Installation of the side brush



ATTENTION! – Wear gloves, goggles and a face mask during assembly. Loose parts must be secured.

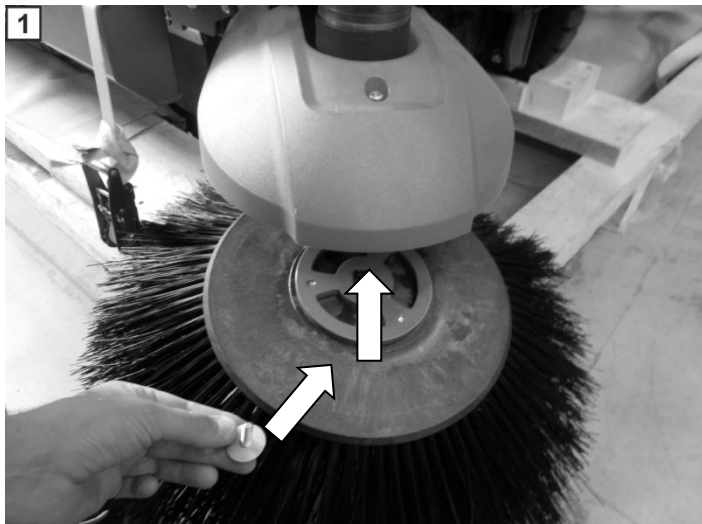

5.3 Dust suction

5.3.1 Operation of the fan



Press the switch to set the fan to position I. The fan remains active until you press it to the opposite position. Turn the switch to the 0 position to switch it off. Generally leave the fan switched on during sweeping. Switch off the fan when sweeping wet refuse.

5.3.2 Operation of the filter vibrator



Press the switch to position I to activate the vibrator. Turn the switch to position 0 to switch it off. When the vibrator is switched on, the dust cake accruing in the filter (accumulation of dust between the filter pleats) is vibrated into the refuse container. High filter performance can only be guaranteed in this way. Depending on the concentration of dust, we recommend that vibration take place at intervals of 5 to 10 minutes.

5.3.3 Dismantling the filter





ATTENTION! – Wear a face mask when removing the filter.

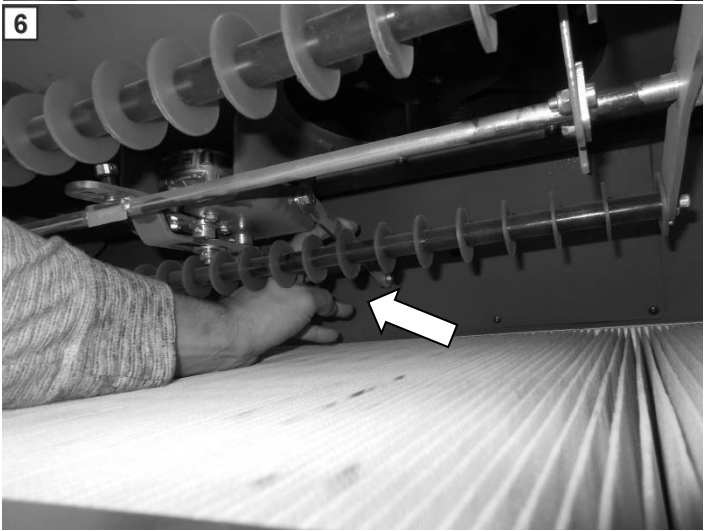
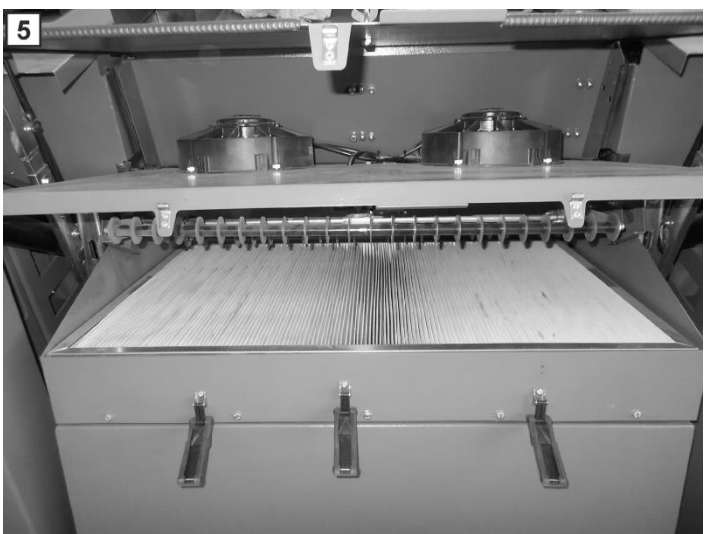
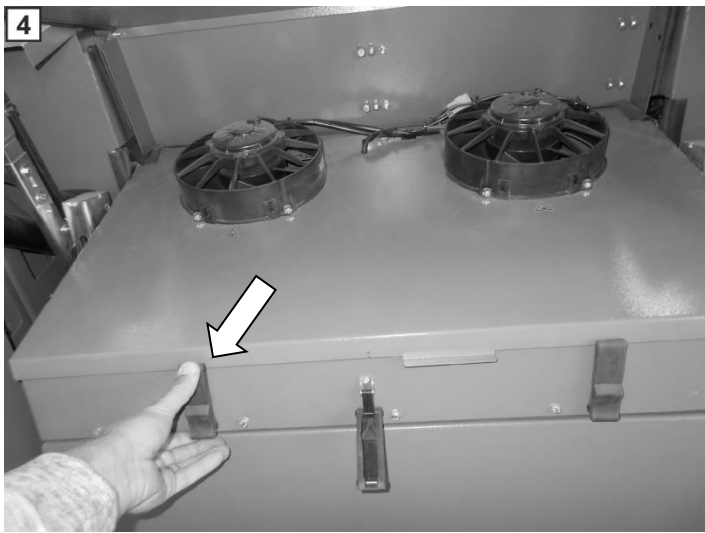
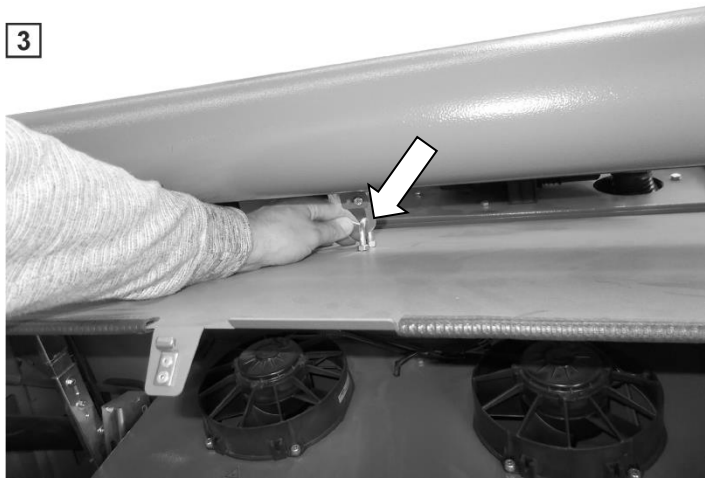



5.3.4 Installation of the filter

 	<p>ATTENTION! – Wear a face mask when removing the filter.</p>
---	---

	<p>Never expose the filter to moisture. The filter material can sustain irreparable damage and adversely affect the air cleaning properties of the dust extractor.</p>
---	--

Ensure that the filter is installed in the correct direction (**1**). Install the filter in reverse order to the steps for its removal. Before installation, please clean the contact surfaces of the filter (**2**). If it is necessary to adjust the filter contact pressure, you can adjust it via the screw connection (**3**).



When removing the filter, be careful, do not damage the gasket from below (**7**).



5.3.5 Filter cleaning



ATTENTION! – When cleaning the filter, wear gloves and a face mask and ensure that the environment is well ventilated.

Clean the filter by tapping it by hand (**1**). Then vacuum the filter (**2**). If the dirt cannot be removed or there is damage, replace the filter. Check that the lower seal is free of damage. Never clean the filter wet! If necessary, you can blow out the filter with compressed air from the clean side.



5.4 High-dumping system

5.4.1 Operation of the high-dumping system



ATTENTION! DANGER! – When working on the high-dumping system, the refuse container with high-dumping arms must be secured against sudden pressure loss in the hydraulics system (such as a hose rupture) by the maintenance support ( 20/5.4.3). There is a danger of body parts being crushed when the high-dumping system is raised or lowered. A second person must cordon off the swivel space. The high-dumping system can be loaded up to a maximum weight of 250 kg (in the refuse container).

Press the switch to raise the refuse container (**1**). Press the switch (**2**) to lower the refuse container. The engine must be running for operation. Press the switch (**3**) to empty the refuse container (tipping). Press the switch (**4**) to retract the refuse container. The tipping function can only be used when the refuse container is almost completely extended.





5.4.2 Cleaning the refuse container.

		<p>ATTENTION! – Only clean the refuse container while wearing gloves, goggles and a face mask. Never clean with compressed air, as particles of dirt which are ejected can lead to injuries and health impairments.</p>
--	--	---

Sweep out the refuse container with a hand brush. If there is any stubborn dirt left in it, soften it with warm water. During cleaning, please ensure that the area leading to the refuse container (**1**) is clear and cleaned.

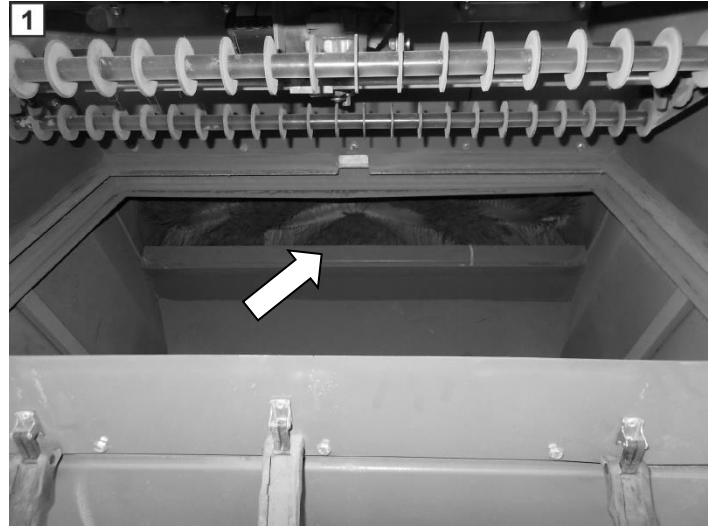

5.4.3 Maintenance support

	<p>ATTENTION! DANGER! - Risk of crushing parts of the body. Wear gloves .</p>

Raise the high-dumping system completely. Loosen the mounting bracket (**1**) of the maintenance support and swivel it towards the lifting cylinder (**2**). Now lower the high-dumping system slowly and guide the maintenance support along the lifting cylinder tube until the high-dumping system is fixed securely (**3**).

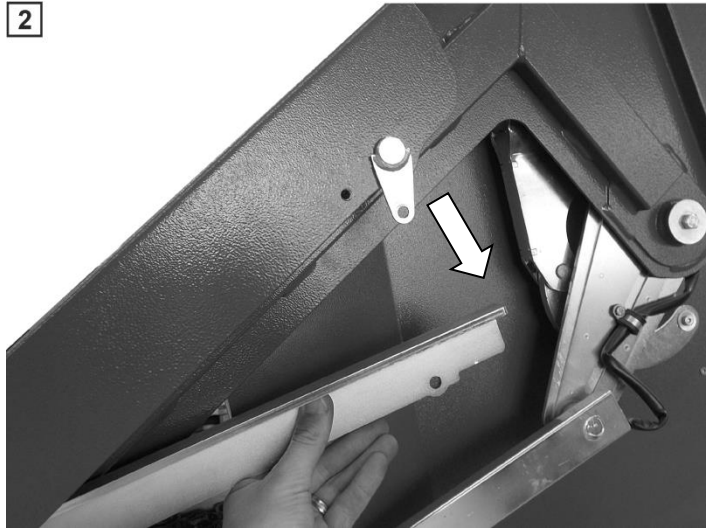

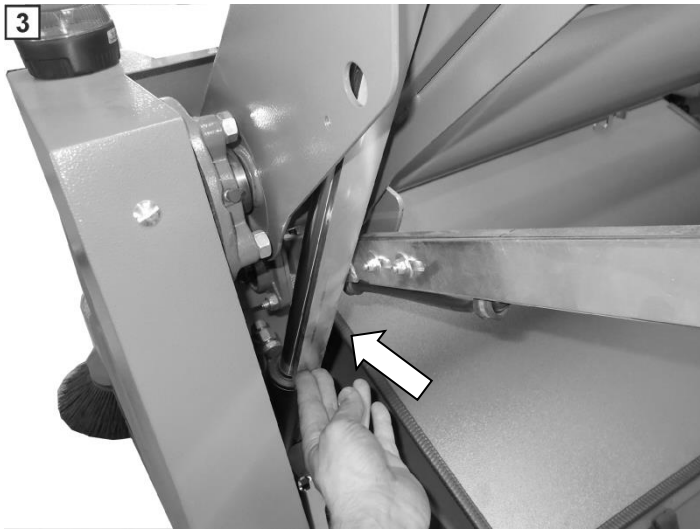

5.5 Fuse box

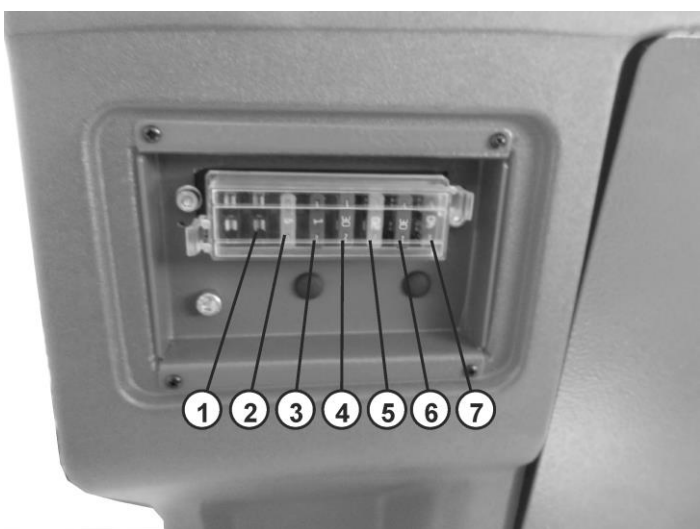

No.	Consumer	Fuse in amps [A]
1	Fan oil cooler (not shown)	20 A
2	Fuel gauge, horn, front lights	5 A
3	All-round light	1 A
4	Vibrator, fan (dust extractor)	30 A
5	Side brush, sweeping rollers, high-dumping system UP/DOWN	20 A
6	Tipping engine (high-dumping system)	30 A
7	Main fuse (all circuits)	40 A

6 Cleaning and maintenance

The regular maintenance of the sweeper serves to preserve the machine, its components and the sweeping result. If performed regularly, the subsequently described maintenance work can extend the lifetime of the equipment!

6.1 Safety instructions for cleaning and maintenance



ATTENTION - The sweeper may not be cleaned using high-pressure or water jet, as these can cause damage! There is a danger of short circuit or other serious damage! Do not use aggressive cleaning agents!



ATTENTION - Personal protective equipment in the form of goggles, breathing protection and gloves must be worn for interior and exterior cleaning of the sweeper!

To clean the machine interior, the side cover must be opened and the seat cover folded. Use a dry cloth for cleaning and blow through the machine with compressed air. Subsequently close the main cover properly once again. For the exterior cleaning of the sweeper, use compressed air and/or a cloth or a wash mitt moistened with warm water or a mild detergent solution.

6.2 General cleaning and maintenance instructions



ATTENTION - For safety reasons, all cleaning and maintenance work may only be carried out when the machine is switched off! To do so, remove the key from the device! Failure to do so may result in serious injury!

For cleaning and maintenance intervals, please refer to the service indicator (see chapter 4.3.2.3) or the maintenance manual! All service and maintenance work must be performed by a qualified technician! If necessary, a Stolzenberg dealer can be contacted at any time! You can find the relevant dealer or service technician for your machine on the manufacturer website!

7 Faults, fault indications and remedy

Fault	Possible cause	Solution
No function display of the control panel	Ignition key not turned to position I	Insert, turn ignition key
	Battery not connected	Connect battery
	Battery flat	Charge battery
	Error in plug-in connections/wiring harness	Contact manufacturer
	Defective fuse	Check cause, replace fuse
Engine will not start	Ignition key not turned to position I	Insert, turn ignition key
	Battery not connected	Connect battery
	Battery flat	Charge battery
	Error in plug-in connections/wiring harness	Contact manufacturer
	Defective fuse	Check cause, replace fuse
	Diesel/petrol or gas tank empty, gas cylinder closed	Replenish fuel, or replace or open the gas cylinder
	Engine will not ignite (smells of fuel)	Spark plugs defective, replace
	Air filter very dirty	Clean or exchange air filter
	Diesel: Preheating time not reached	Wait for the preheating time (see chapter 5)
	Seat contact switch not activated	Operator must sit on the seat
	Starter battery flat	Charge battery
Sweeping rollers/ side brush without a function	Switch without a function	Contact manufacturer
	Valves on the hydraulics block will not switch	Check service connections, contact Service
	Defective fuse	Check cause, replace fuse
main broom housing blocked	Full debris container	Emptying debris container
	Side brushes or main broom worn	Readjust or exchange
	Main broom housing rubber skirts worn or damaged	Check and exchange
	Main brooms blocked by heavy debris, wires, etc.	Disassemble main brooms and remove blockages
	Main broom housing blocked	Remove main brooms and clean housing
	Sweeping rollers very dirty dried sweepings	Cleaning the sweeping rollers
dust development high, unsatisfying filter performance	Side brooms are raising dust	Lift and switch off side brooms
	Fan without function	check ease of fan run, remove blockages
	Filter fully loaded	Use filter shaker, disassemble filter and clean it with pressed air (from filtered side only!)
	Filter not installed correctly / gasket damaged	Check the location of the filter, Replace seal
	Air leakage inside the filter chamber / move leak air	Check filter chamber and sealings
	Main broom housing rubber skirts worn or damaged	Check and exchange
Not moving	Engine is not working	Start engine The operator must be sitting on the seat
	Hydraulic oil volume too low	Top up hydraulic oil
	Drive wheel blocked	Identify cause, contact manufacturer
	Bowden cables of drive pedals adjusted, jammed, cracked	Check, readjust, clean, oil and replace if necessary.
	Fuses for engine control unit defective	Refer to the operating manual for the respective engine and replace the fuse.

Fault	Possible cause	Solution
Filter vibrator not working	Vibrator switch not pressed	Press vibrator switch
	Vibrator rod system jammed	Clear jam, oil if necessary.
	Defective fuse	Check cause, replace fuse
Inadequate cleaning performance by vibrator	Lamellas do not engage in filter pleats	Adjust vibrator rod system
Fan not working	Fan switch not pressed	Press fan switch
	Defective fuse	Check cause, replace fuse

8 Maintenance table

8.1 Daily maintenance

- Check the machine for visible damage and malfunctions.
- Empty the dust container.
- Check the broom and roller tunnels for parts that have got stuck, or dirt particles sticking to them, which narrow the broom tunnel and restrict the free movement of the roller brushes.
- Check the fuel status, if required, refill.
- Check the state of the dust filter, clean it if required

8.2 Weekly maintenance

- Clean the air inlet at the engine radiator
- Clean the air filter

8.3 In addition, every 50 operating hours

- Check the sweeping rollers for wear and foreign bodies, replace them if required
- Check the length of the bristles of the sweeping roller, less than 70 mm, please replace sweeping roller
- Check the side broom setting for wear, if required, set it or replace it.
- Check Hydraulic oil level and check for leaks.

8.3 In addition, every 100 operating hours

- check all the belts for cracks or impermissible elongation and re-place them if required
- Check bearing for wear
- Check all the seals for damage or correct seating.
- Check the cable connections for firmness, replace faulty cables
- Check the dust filter, replace if required.
- Check Hydraulic oil filter, replace if required.
- Check the collected dust for foreign bodies and clean it.
- In addition, follow the instructions of the engine manufacturer.

9 Nameplate

The nameplate with all the important information about this sweeper is located on the right side (in the driving direction) on the filter chamber housing.

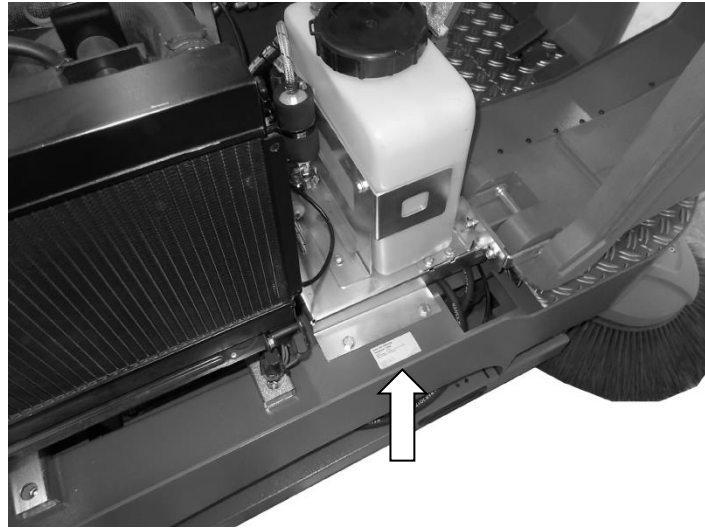

10 Accessories and spare parts

Accessories and spare parts must conform to the requirements of the manufacturer. This is ensured by using genuine replacement parts. Spare parts please refer to the enclosed spare parts list.

11 Warranty

Information on the guarantee and warranty claims can be found in the General Terms and Conditions (GTC) on the manufacturer's website.

12 Transport der Kehmaschine



ATTENTION! The eyes are designated for transport safety only! They must not be misused as lifting points! Serious injuries and damage to the machine may result if this is not observed!

Screw the fixing lugs included in the scope of delivery into the threaded holes provided in the frame (**1** - **2**).

1

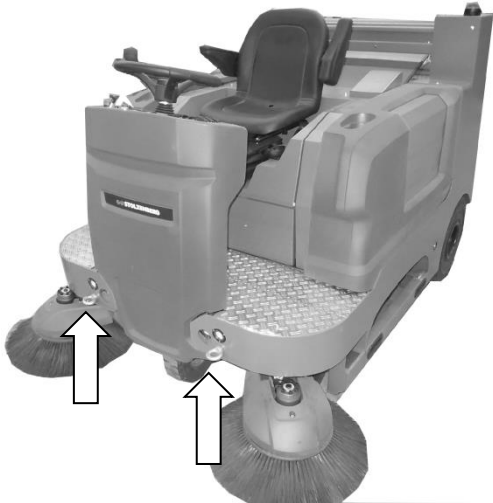

2

