

Washer-Extractors

Cabinet Hardmount

Design 2 and 3 Models

Refer to Page 8 for Model Identification



Installation/Operation/Maintenance

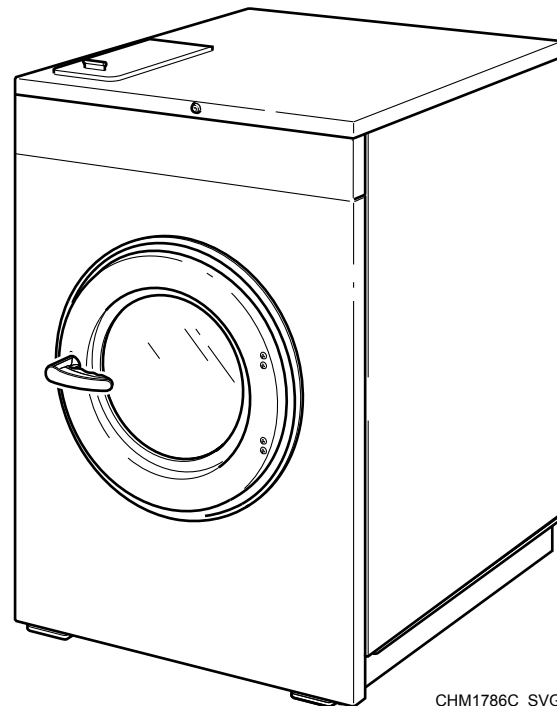

CHM1786C_SVG

Original Instructions

Keep These Instructions for Future Reference.

(If this machine changes ownership, this manual must accompany machine.)



www.alliancelandry.com

Part No. F8429301ENR18
April 2017

Table of Contents

Safety Information.....	5
Explanation of Safety Messages.....	5
Important Safety Instructions.....	5
Safety Decals.....	6
Operator Safety.....	6
Introduction.....	8
Model Identification.....	8
Delivery Inspection.....	13
Serial Plate Location.....	13
Replacement Parts	14
Customer Service.....	14
Manufacturing Date.....	14
Specifications and Dimensions.....	15
General Specifications.....	15
Machine Dimensions.....	18
20-60 Models.....	18
80 and 100 Models	20
Mounting Bolt Hole Locations – 20 and 30 Models.....	22
Mounting Bolt Hole Locations - 40 and 60 Models.....	24
Mounting Bolt Hole Locations – 80 and 100 Models	26
Floor Mounting Layout – 20-60 Models.....	28
Floor Mounting Layout – 80 and 100 Models.....	31
Installation.....	36
Pallet Jack Cover Plate Removal (80 and 100 Models Only).....	36
Single Machine Foundation Requirements.....	36
Machine Installation with Existing Floor.....	36
Elevated Pad Installation with Existing Floor.....	36
Elevated Base Frame Installation with Existing Floor.....	36
New Foundation.....	37
Isolated Pad Installation.....	37
Machine Foundation and Pad Installation.....	38
Machine Installation.....	39
Machine Mounting and Grouting.....	41
Drain Connection.....	44
Water Connection Requirements.....	46
Electrical Installation Requirements.....	48
Input Power Conditioning.....	49
Input Voltage Requirements.....	49

Circuit Breakers and Quick Disconnects.....	49
Connection Specifications.....	50
Single-Phase Connections (120V).....	50
Single-Phase Connections (220V).....	50
Three-Phase Connections.....	51
Grounding.....	51
Phase Adder.....	52
Thermal Overload Protector.....	52
North American Approval.....	53
CE Approval.....	58
Steam Requirements (Steam Heat Option Only).....	63
Supply Dispensing.....	63
External Supplies.....	63
Chemical Injection Using Internal 24VAC Control Transformer.....	63
Chemical Injection Using External AC Power Source.....	65
External Supply Signals.....	65
Connection of External Liquid Supplies.....	67
Start Up.....	68
Pallet Jack cover Plate Installation (80 and 100 Models Only).....	68
Basket Rotation.....	68
Operation.....	69
Operating Instructions.....	69
Maintenance.....	71
Maintenance.....	71
Daily.....	71
Beginning of Day.....	71
End of Day.....	71
Monthly.....	71
Yearly.....	72
Care of Stainless Steel.....	74
Disposal of Unit.....	76
China Restriction of hazardous substances (RoHS).....	77

Safety Information

Explanation of Safety Messages

Precautionary statements (“DANGER,” “WARNING,” and “CAUTION”), followed by specific instructions, are found in this manual and on machine decals. These precautions are intended for the personal safety of the operator, user, servicer, and those maintaining the machine.

	DANGER
Indicates an imminently hazardous situation that, if not avoided, will cause severe personal injury or death.	

	WARNING
Indicates a hazardous situation that, if not avoided, could cause severe personal injury or death.	

	CAUTION
Indicates a hazardous situation that, if not avoided, may cause minor or moderate personal injury or property damage.	

Additional precautionary statements (“IMPORTANT” and “NOTE”) are followed by specific instructions.

IMPORTANT: The word “IMPORTANT” is used to inform the reader of specific procedures where minor machine damage will occur if the procedure is not followed.

NOTE: The word “NOTE” is used to communicate installation, operation, maintenance or servicing information that is important but not hazard related.

Important Safety Instructions

	WARNING
To reduce the risk of fire, electric shock, serious injury or death to persons when using your washer, follow these basic precautions:	
W023	

- Read all instructions before using the washer.
- Install the washer according the INSTALLATION instructions. Refer to the EARTH/GROUND instructions in the IN-

STALLATION manual for the proper earth/ground connection of the washer. All connections for water, drain, electrical power and earth/ground must comply with local codes and be made by licensed personnel when required. It is recommended that the machine be installed by qualified technicians.

- Do not install or store the washer where it will be exposed to water and/or weather.
- To prevent fire and explosion, keep the area around machine free from flammable and combustible products. Do not add the following substances or textiles containing traces of the following substances to the wash water: gasoline, kerosene, waxes, cooking oils, vegetable oils, machine oils, dry-cleaning solvents, flammable chemicals, thinners, or other flammable or explosive substances. These substances give off vapors that could ignite, explode or cause the fabric to catch fire by itself.
- Under certain conditions, hydrogen gas may be produced in a hot water system that has not been used for two weeks or more. HYDROGEN GAS IS EXPLOSIVE. If the hot water system has not been used for such a period, before using a washing machine or combination washer-dryer, turn on all hot water faucets and let the water flow from each for several minutes. This will release any accumulated hydrogen gas. The gas is flammable, do not smoke or use an open flame during this time.
- To reduce the risk of an electric shock or fire, DO NOT use an extension cord or an adapter to connect the washer to the electrical power source.
- Do not allow children to play on or in the washer. Close supervision of children is necessary when the washer is used near children. This appliance is not intended for use by young children or infirm persons without supervision. Young children should be supervised to ensure that they do not play with the appliance. This is a safety rule for all appliances.
- DO NOT reach and/or climb into the tub or onto the washer, ESPECIALLY if the wash drum is moving. This is an imminently hazardous situation that, if not avoided, will cause severe personal injury or death.
- Never operate the washer with any guards, panels and/or parts removed or broken. DO NOT bypass any safety devices or tamper with the controls.
- Use washer only for its intended purpose, washing textiles. Never wash machine parts or automotive parts in the machine. This could result in serious damage to the basket or tub.
- Use only low-sudsing, no-foaming types of commercial detergent. Be aware that hazardous chemicals may be present. Wear hand and eye protection when adding detergents and chemicals. Always read and follow manufacturer’s instructions on packages of laundry and cleaning aids. Heed all warnings or precautions. To reduce the risk of poisoning or

Safety Information

chemical burns, keep them out of the reach of children at all times [preferably in a locked cabinet].

- Do not use fabric softeners or products to eliminate static unless recommended by the manufacturer of the fabric softener or product.
- Always follow the fabric care instructions supplied by the textile manufacturer.
- Loading door **MUST BE CLOSED** any time the washer is to fill, tumble or spin. **DO NOT** bypass the loading door switch by permitting the washer to operate with the loading door open. Do not attempt to open the door until the washer has drained and all moving parts have stopped.
- Be aware that hot water is used to flush the supply dispenser. Avoid opening the dispenser lid while the machine is running.
- Do not attach anything to the supply dispenser's nozzles, if applicable. The air gap must be maintained.
- Do not operate the machine without the water reuse plug or water reuse system in place, if applicable.
- Be sure water connections have a shut-off valve and that fill hose connections are tight. **CLOSE** the shut-off valves at the end of each wash day.
- Keep washer in good condition. Bumping or dropping the washer can damage safety features. If this occurs, have washer checked by a qualified service person.
- **DANGER:** Before inspecting or servicing machine, power supply must be turned **OFF**. The servicer needs to wait for at least 5 minutes after turning the power **OFF** and needs to check for residual voltage with a voltage meter. The inverter capacitor or EMC filter remains charged with high voltage for some time after powering **OFF**. This is an imminently hazardous situation that, if not avoided, will cause severe personal injury or death.
- Do not repair or replace any part of the washer, or attempt any servicing unless specifically recommended in the user-maintenance instructions or in published user-repair instructions that the user understands and has the skills to carry out. **ALWAYS** disconnect the washer from electrical, power and water supplies before attempting any service.
- Disconnect the power by turning off the circuit breaker or by unplugging the machine. Replace worn power cords.
- Before the washer is removed from service or discarded, remove the door to the washing compartment.
- Failure to install, maintain, and/or operate this washer according to the manufacturer's instructions may result in conditions which can produce bodily injury and/or property damage.

NOTE: The WARNINGS and IMPORTANT SAFETY INSTRUCTIONS appearing in this manual are not meant to cover all possible conditions and situations that may occur. Common sense, caution and care must be exercised when installing, maintaining, or operating the washer.

Any problems or conditions not understood should be reported to the dealer, distributor, service agent or the manufacturer.



WARNING

Machine installations must comply with minimum specifications and requirements stated in the applicable Installation Manual, any applicable municipal building codes, water supply requirements, electrical wiring regulations and any other relevant statutory regulations. Due to varied requirements and applicable local codes, this machine must be installed, adjusted, and serviced by qualified maintenance personnel familiar with applicable local codes and the construction and operation of this type of machinery. They must also be familiar with the potential hazards involved. Failure to observe this warning may result in personal injury, property damage, and/or equipment damage, and will void the warranty.

W820

IMPORTANT: Ensure that the machine is installed on a level floor of sufficient strength. Ensure that the recommended clearances for inspection and maintenance are provided. Never allow the inspection and maintenance space to be blocked.



WARNING

Never touch internal or external steam pipes, connections, or components. These surfaces can be extremely hot and will cause severe burns. The steam must be turned off and the pipe, connections, and components allowed to cool before the pipe can be touched.

SW014

Safety Decals

Safety decals appear at crucial locations on the machine. Failure to maintain legible safety decals could result in injury to the operator or service technician.

Use manufacturer-authorized spare parts to avoid safety hazards.

Operator Safety



WARNING

NEVER insert hands or objects into basket until it has completely stopped. Doing so could result in serious injury.

SW012

The following maintenance checks must be performed daily:

1. Verify that all warning labels are present and legible, replace as necessary.
2. Check door interlock before starting operation of the machine:
 - a. Attempt to start the machine with the door open. The machine should not start.
 - b. Close the door without locking it and start the machine. The machine should not start.
 - c. Attempt to open the door while a cycle is in progress. The door should not open.

If the door lock and interlock are not functioning properly, disconnect power and call a service technician.

3. Do not attempt to operate the machine if any of the following conditions are present:
 - a. The door does not remain securely locked during the entire cycle.
 - b. Excessively high water level is evident.
 - c. Machine is not connected to a properly grounded circuit.

Do not bypass any safety devices in the machine.

	WARNING
Operating the machine with severe out-of-balance loads could result in personal injury and serious equipment damage.	
W728	

Introduction

Model Identification

Information in this manual is applicable to Design 2 models or later. Refer to the 12th position of the model number (e.g. *CN040*YVXU 2 001):

Models						
20 Pound [9.1 Kg]	CCN020HNF	HCN020HCF	ICN020HNF	SCH020WXV	SCN020JXF	SCU020WCV
	CCN020HNV	HCN020HDF	ICN020HNV	SCH020WYF	SCN020JYF	SCU020WDV
	CCN020KNF	HCN020HEF	ICN020KCF	SCH020WYV	SCN020JYV	SCU020WEV
	CCN020KNV	HCN020HNF	ICN020KCV	SCL020GNF	SCN020KNF	SCU020WLF
	HCD020LDF	HCN020HNV	ICN020KDF	SCL020GNV	SCN020KNV	SCU020WLV
	HCD020LDV	HCN020HXF	ICN020KDV	SCL020HNF	SCN020LCF	SCU020WXV
	HCH020GNF	HCN020HYF	ICN020KEF	SCL020HNV	SCN020LCV	SCU020WYF
	HCH020HDF	HCN020KCF	ICN020KEV	SCL020JCF	SCN020LDF	SCU020WYV
	HCH020HNF	HCN020KCV	ICN020KNF	SCL020JCV	SCN020LDV	SCY020JDV
	HCH020HNV	HCN020KDF	ICN020KNV	SCL020JDF	SCN020LEF	SCY020JEF
	HCH020HXF	HCN020KDV	ICN020KXF	SCL020JDV	SCN020LEV	SCY020KNF
	HCH020KCF	HCN020KEF	ICN020KYF	SCL020JEF	SCN020LXF	SCY020KNV
	HCH020KCV	HCN020KEV	ICN020KYV	SCL020JEV	SCN020LYF	SCY020LEV
	HCH020KDF	HCN020KXF	SCD020JDF	SCL020JXF	SCN020LYV	SCY020WEV
	HCH020KDV	HCN020KYF	SCD020LDF	SCN020JXV	SCN020WCF	SCZ020GNF
	HCH020KEF	HCN020KYV	SCD020LDV	SCL020JYF	SCN020WCV	SCZ020KNV
	HCH020KEV	HCN020ZCF	SCH020HNV	SCL020JYV	SCN020WDF	UCH020GNF
	HCH020KXV	HCN020ZCV	SCH020JCF	SCL020KNF	SCN020WDV	UCH020GNV
	HCH020ZCF	HCN020ZDF	SCH020JCV	SCL020KNV	SCN020WEF	UCH020HNF
	HCH020ZCV	HCN020ZDV	SCH020JDF	SCL020LCF	SCN020WEV	UCH020HNV
	HCH020ZDF	HCN020ZEF	SCH020JDV	SCL020LDF	SCN020WYF	UCH020KNF
	HCH020ZDV	HCN020ZEV	SCH020JEF	SCL020LDV	SCN020WYV	UCH020KNV
	HCH020ZEF	HCN020ZXF	SCH020JEV	SCL020LEF	SCU020GNF	UCL020GNF
	HCH020ZEV	HCN020ZYF	SCH020JXF	SCL020LEV	SCU020GNV	UCL020GNV
	HCH020ZXV	HCN020ZYV	SCH020JXV	SCL020LLV	SCU020HNF	UCL020HNF
	HCL020GNF	HCU020GNF	SCH020JYF	SCL020LXF	SCU020JCF	UCL020HNV
	HCL020HDF	HCU020HEF	SCH020JYV	SCL020LXV	SCU020JCV	UCL020KNF
	HCL020HNF	HCU020HNF	SCH020KNF	SCL020LYF	SCU020JDF	UCL020KNV
	HCL020HNV	HCU020HNV	SCH020KNV	SCL020LYV	SCU020JDV	UCN020GNF
	HCL020HXF	HCU020HXF	SCH020LCF	SCL020WCF	SCU020JEF	UCN020GNV
	HCL020KCF	HCU020KCF	SCH020LDF	SCL020WCV	SCU020JEV	UCN020HNF
	HCL020KCV	HCU020KCV	SCH020LDV	SCL020WEF	SCU020JLF	UCN020HNV
	HCL020KDF	HCU020KEV	SCH020LEF	SCL020WEV	SCU020JLV	UCN020KNF
	HCL020KDV	HCU020KLF	SCH020LEV	SCL020WLF	SCU020JXF	UCN020KNV
	HCL020KEF	HCU020KLV	SCH020LLV	SCL020WLV	SCU020JXV	UCU020GNF
	HCL020KEV	HCU020KXV	SCH020LXF	SCL020WXF	SCU020JYF	UCU020GNV
	HCL020KXV	HCU020KYF	SCH020LXV	SCL020WXV	SCU020JYV	UCU020HNF
	HCL020ZCF	HCU020KYV	SCH020LYF	SCL020WYF	SCU020KNF	UCU020HNV
	HCL020ZCV	HCU020ZCV	SCH020LYV	SCL020WYV	SCU020LCV	UCU020KNF
	HCL020ZDF	HCU020ZEV	SCH020WCF	SCN020GNF	SCU020LDV	UCU020KNV
HCL020ZDV	HCU020ZLF	SCH020WCV	SCN020HNF	SCU020LEV	UCY020KNF	
HCL020ZEF	HCU020ZLV	SCH020WEF	SCN020HNV	SCU020LLF	UCY020KNV	
HCL020ZEV	HCU020ZXV	SCH020WEV	SCN020JCF	SCU020LLV	UCZ020GNF	
HCL020ZXV	HCU020ZYF	SCH020WLF	SCN020JCV	SCU020LXV	UCZ020HNF	
HCN020GNF	HCZ020GNF	SCH020WLV	SCN020JDF	SCU020LYV		
HCN020GNV	ICN020GNF	SCH020WXF	SCN020JEF	SCU020WCF		

Table continues...

Models						
60 Pound [27.2 Kg]	CCN060HNF	HCL060ZEV	HCU060ZLV	SCH060WLF	SCN060JXF	SCU060LLV
	CCN060HNV	HCL060ZXV	HCU060ZYF	SCH060WLV	SCN060JXV	SCU060LXV
	CCN060KNF	HCN060GNF	HCU060ZYV	SCH060WXF	SCN060JYF	SCU060LYV
	CCN060KNV	HCN060GNV	ICN060GNF	SCH060WXV	SCN060JYV	SCU060WCF
	HCD060LDF	HCN060HCF	ICN060HNF	SCH060WYF	SCN060KNF	SCU060WCV
	HCD060LDV	HCN060HDF	ICN060HNV	SCH060WYV	SCN060KNV	SCU060WDV
	HCH060GNF	HCN060HEF	ICN060KCF	SCL060GNF	SCN060LCF	SCU060WEV
	HCH060GNV	HCN060HNF	ICN060KCV	SCL060GNV	SCN060LCV	SCU060WLV
	HCH060HCF	HCN060HNV	ICN060KDF	SCL060HNF	SCN060LDF	SCU060WXV
	HCH060HDF	HCN060HXF	ICN060KDV	SCL060HNV	SCN060LDV	SCU060WYF
	HCH060HNF	HCN060HYF	ICN060KEF	SCL060JCF	SCN060LEF	SCU060WYV
	HCH060HNV	HCN060KCF	ICN060KEV	SCL060JCV	SCN060LEV	SCY060JDV
	HCH060HXF	HCN060KCV	ICN060KNF	SCL060JDF	SCN060LXF	SCY060JEF
	HCH060KCF	HCN060KDF	ICN060KNV	SCL060JDV	SCN060LXV	SCY060KNF
	HCH060KCV	HCN060KDV	ICN060KXF	SCL060JEF	SCN060LYF	SCY060KNV
	HCH060KDF	HCN060KEF	ICN060KYF	SCL060JEV	SCN060LYV	SCY060LEV
	HCH060KDV	HCN060KEV	ICN060KYV	SCL060JXF	SCN060WCF	SCY060WEV
	HCH060KEF	HCN060KXF	SCD060JDF	SCL060JYF	SCN060WCV	UCH060GNF
	HCH060KEV	HCN060KYF	SCD060LDF	SCL060JYV	SCN060WDF	UCH060GNV
	HCH060KXF	HCN060ZCF	SCD060LDV	SCL060KNF	SCN060WDV	UCH060HNF
	HCH060KXV	HCN060ZCF	SCH060GNF	SCL060KNV	SCN060WEF	UCH060HNV
	HCH060ZCF	HCN060ZCV	SCH060GNV	SCL060LCF	SCN060WEV	UCH060KNF
	HCH060ZCV	HCN060ZDF	SCH060HNF	SCL060LCV	SCN060WYF	UCH060KNV
	HCH060ZDF	HCN060ZDV	SCH060HNV	SCL060LEF	SCN060WYV	UCL060GNF
	HCH060ZDV	HCN060ZEF	SCH060JCF	SCL060LEV	SCU060GNF	UCL060GNV
	HCH060ZEF	HCN060ZEV	SCH060JCV	SCL060LLF	SCU060GNV	UCL060HNF
	HCH060ZEV	HCN060ZXF	SCH060JDF	SCL060LXF	SCU060HNF	UCL060HNV
	HCH060ZXV	HCN060ZYF	SCH060JDV	SCL060LXV	SCU060HNV	UCL060KNF
	HCL060GNF	HCN060ZYV	SCH060JEF	SCL060LYV	SCU060JCF	UCL060KNV
	HCL060GNV	HCN060KYV	SCH060JEV	SCL060WCV	SCU060JCV	UCN060GNF
	HCL060HCF	HCU060GNF	SCH060JXF	SCL060WDF	SCU060JDF	UCN060GNV
	HCL060HDF	HCU060GNV	SCH060JYF	SCL060WDF	SCU060JDV	UCN060HNF
	HCL060HNF	HCU060HLF	SCH060JYV	SCL060WLF	SCU060JEF	UCN060HNV
	HCL060HNV	HCU060HNF	SCH060JYV	SCL060WLV	SCU060JEV	UCN060KNF
	HCL060HXF	HCU060HNV	SCH060KNF	SCL060WLX	SCU060JLF	UCN060KNV
	HCL060KCF	HCU060HXF	SCH060KNV	SCL060WXF	SCU060JLV	UCU060GNF
	HCL060KCV	HCU060KCF	SCH060LCF	SCL060WXV	SCU060JLX	UCU060GNV
	HCL060KDF	HCU060KCV	SCH060LCV	SCL060WYF	SCU060JXF	UCU060HNF
	HCL060KDV	HCU060KEV	SCH060LEF	SCL060WYV	SCU060JXV	UCU060HNV
	HCL060KEF	HCU060KLF	SCH060LEV	SCN060GNF	SCU060JYF	UCU060KNF
HCL060KEV	HCU060KLV	SCH060LLF	SCN060GNV	SCU060JYV	UCU060KNV	
HCL060KXF	HCU060KYF	SCH060LXF	SCN060HNF	SCU060KNF	UCY060KNF	
HCL060KXV	HCU060KYV	SCH060LXV	SCN060HNV	SCU060KNV	UCY060KNV	
HCL060ZCF	HCU060KXV	SCH060LXV	SCN060JCF	SCU060LCV		
HCL060ZCV	HCU060ZCF	SCH060LYV	SCN060JCV	SCU060LDV		
HCL060ZDF	HCU060ZCV	SCH060WCV	SCN060JDF	SCU060LEV		
HCL060ZDV	HCU060ZEV	SCH060WDF	SCN060JEF	SCU060LLF		
HCL060ZEV	HCU060ZLF	SCH060WDF				

Table continues...

Models							
80 Pound [36.3 Kg]	CCN080HNF	HCN080HYV	HCU080KYV	SCL080HNF	SCN080WYF	SCU080WYV	
	CCN080HNV	HCN080KCF	HCU080ZCF	SCL080KNF	SCN080WYV	SCY080KNF	
	CCN080KNV	HCN080KCV	HCU080ZCV	SCL080KNV	SCU080GNF	SCY080KNV	
	HCD080LDF	HCN080KDF	HCU080ZYF	SCL080LCF	SCU080HNF	UCH080GNF	
	HCD080LDV	HCN080KDV	HCU080ZYV	SCN080GNF	SCU080JCF	UCH080HNF	
	HCH080GNF	HCN080KEF	ICN080GNF	SCN080HNF	SCU080JCV	UCH080HNV	
	HCH080HNF	HCN080KEV	ICN080HNF	SCN080JCF	SCU080JDF	UCH080KNF	
	HCH080HNV	HCN080KXF	ICN080HNV	SCN080JCV	SCU080JDV	UCH080KNV	
	HCH080KDF	HCN080KYF	ICN080KCF	SCN080JDF	SCU080JEF	UCL080GNF	
	HCH080KDV	HCN080KYV	ICN080KCV	SCN080JYF	SCU080JEV	UCL080HNF	
	HCH080ZDF	HCN080ZCF	ICN080KDF	SCN080JYV	SCU080JLF	UCL080HNV	
	HCH080ZDV	HCN080ZCV	ICN080KDV	SCN080KNF	SCU080JLV	UCL080KNF	
	HCL080GNF	HCN080ZDF	ICN080KEF	SCN080KNV	SCU080JXF	UCL080KNV	
	HCL080HNF	HCN080ZDV	ICN080KEV	SCN080LCF	SCU080JXV	UCN080GNF	
	HCL080HNV	HCN080ZEF	ICN080KNF	SCN080LCV	SCU080JYF	UCN080HNF	
	HCL080KDF	HCN080ZEV	ICN080KNV	SCN080LDF	SCU080JYV	UCN080HNV	
	HCL080KDV	HCN080ZXF	ICN080KYF	SCN080LDV	SCU080KNV	UCN080KNF	
	HCL080ZDF	HCN080ZYF	ICN080KYV	SCN080LEF	SCU080LCV	UCN080KNV	
	HCL080ZDV	HCN080ZYV	SCD080LDF	SCN080LXF	SCU080LDV	UCU080GNF	
	HCN080GNF	HCU080GNF	SCD080LDV	SCN080LYF	SCU080LEV	UCU080HNF	
	HCN080HCF	HCU080HCF	SCH080GNF	SCN080LYV	SCU080LXV	UCU080HNV	
	HCN080HCV	HCU080HNF	SCH080HNF	SCN080WCF	SCU080LYV	UCU080KNF	
	HCN080HDF	HCU080HXF	SCH080KNF	SCN080WCV	SCU080WCV	UCU080KNV	
	HCN080HNF	HCU080KCF	SCH080KNV	SCN080WDF	SCU080WDV	UCY080KNF	
	HCN080HNV	HCU080KCV	SCH080LCF	SCN080WDV	SCU080WEV	UCY080KNV	
	HCN080HYF	HCU080KYF	SCL080GNF	SCN080WEV	SCU080WXV		
	100 Pound [45.4 Kg]	CCN100HNF	HCN100HNF	HCN100ZXF	SCH100KNV	SCN100WCF	UCL100HNF
		CCN100HNV	HCN100HNV	HCN100ZXV	SCL100GNF	SCN100WCV	UCL100HNV
		HCH100GNF	HCN100KCF	HCN100ZYF	SCL100KNF	SCN100WDF	UCL100KNF
		HCH100HNF	HCN100KCV	HCN100ZYV	SCL100KNV	SCN100WDV	UCL100KNV
HCH100HNV		HCN100KDF	HCU100HNV	SCN100GNF	SCN100WEF	UCN100GNF	
HCH100KDF		HCN100KDV	ICN100GNF	SCN100JCF	SCN100WEV	UCN100HNF	
HCH100KDV		HCN100KEF	ICN100HNF	SCN100KNF	SCN100WXF	UCN100HNV	
HCH100ZDF		HCN100KEV	ICN100HNV	SCN100KNV	SCN100WXV	UCN100KNV	
HCH100ZDV		HCN100KXF	ICN100KCF	SCN100LCF	SCN100WYF	UCU100HNF	
HCL100GNF		HCN100KXV	ICN100KCV	SCN100LCV	SCN100WYV	UCU100HNV	
HCL100HNF		HCN100KYF	ICN100KDV	SCN100LDF	SCU100KNV	UCU100KNF	
HCL100HNV		HCN100KYV	ICN100KEV	SCN100LDV	SCY100KNF	UCU100KNV	
HCL100KDF		HCN100ZCF	ICN100KNF	SCN100LEF	UCH100GNF	UCY100HNF	
HCL100KDV		HCN100ZCV	ICN100KNV	SCN100LEV	UCH100HNF	UCY100KNV	
HCL100ZDF		HCN100ZDF	ICN100KXV	SCN100LXF	UCH100HNV		
HCL100ZDV		HCN100ZDV	ICN100KYV	SCN100LXV	UCH100KNF		
HCN100GNF		HCN100ZEF	SCH100GNF	SCN100LYF	UCH100KNV		
HCN100HCF		HCN100ZEV	SCH100KNF	SCN100LYV	UCL100GNF		

Delivery Inspection

Upon delivery, visually inspect crate, protective cover, and unit for any visible shipping damage. If signs of possible damage are evident, have the carrier note the condition on the shipping papers before the shipping receipt is signed, or advise the carrier of the condition as soon as it is discovered.

Serial Plate Location

The serial plate is located at the rear of the machine and inside door. Provide the machine's serial number and model number when ordering parts or seeking technical assistance. Refer to *Figure 1*.

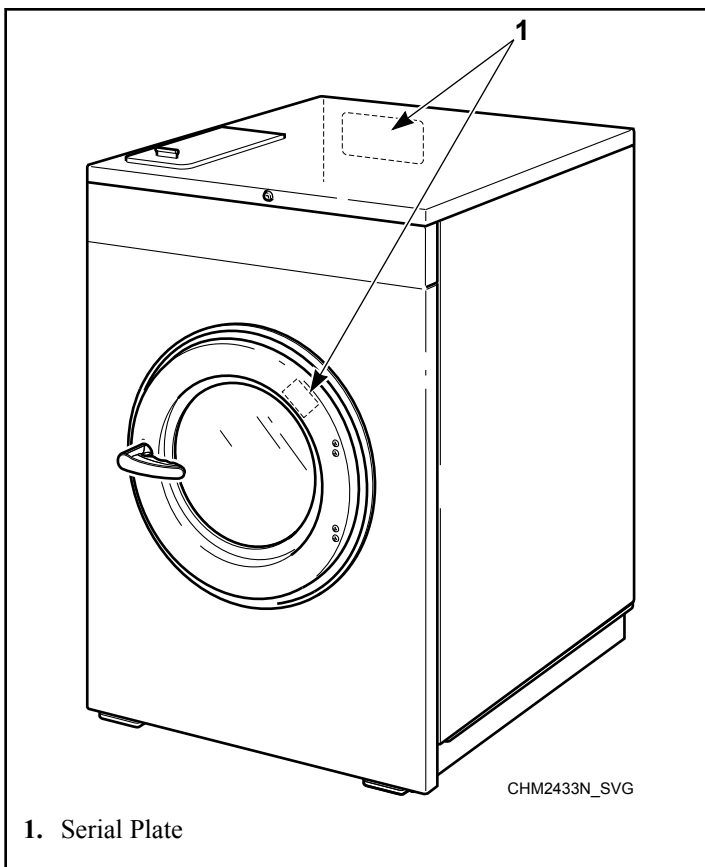

Figure 1

Manufacturing Date

The manufacturing date for your unit can be found on the serial number. The first two digits indicate the year. The third and fourth digits indicate the month. For example, a unit with serial number 1505000001 was manufactured in May 2015.

ERC

Replacement Parts

If literature or replacement parts are required, contact the source from which the machine was purchased or contact Alliance Laundry Systems at +1 (920) 748-3950 for the name and address of the nearest authorized parts distributor.

Customer Service

For technical assistance, contact your local distributor or contact:

Alliance Laundry Systems
Shepard Street
P.O. Box 990
Ripon, WI 54971-0990
U.S.A.
www.alliancelaundry.com
Phone: +1 (920) 748-3121 Ripon, Wisconsin

Specifications and Dimensions

General Specifications

Model	20		30	40	60	80	100
Overall Dimensions							
Overall width, in. [mm]	26.0 [660]		29.0 [737]	30.63 [778]	34.06 [865]	41.5 [1054]	41.5 [1054]
Overall height, in. [mm]	Design 2	43.5 [1105]	46.45 [1180]	48.7 [1237]	51.39 [1305]	57.66 [1465]	57.66 [1465]
	Design 3	44.5 [1130]					
Overall depth, in. [mm]	30.85 [784]		35.29 [896]	42.25 [1073]	44.7 [1135]	48.6 [1234]	52.6 [1336]
Weight and Shipping Information							
Net weight, lbs. [kg]	335 [152]		460 [209]	550 [249]	695 [315]	1210 [549]	1260 [572]
Standard shipping weight, lbs. [kg]	365 [166]		495 [225]	590 [268]	745 [338]	1260 [572]	1310 [594]
Standard shipping volume, ft ³ [m ³]	Design 2	26.5 [0.75]	36 [1.01]	44 [1.24]	57 [1.61]	81 [2.29]	87 [2.4]
	Design 3	27 [0.77]					
Standard shipping dimensions (WxDxH), in. [mm]	Design 2	28 x 33.8 x 48.4 [711 x 859 x 1229]	31.5 x 38.3 x 51.3 [800 x 973 x 1303]	32.5 x 43.5 x 53.6 [826 x 1105 x 1361]	37.5 x 46.9 x 56.3 [953 x 1191 x 1430]	44 x 54.5 x 58.6 [1118 x 1384 x 1488]	44 x 58.5 x 58.6 [1118 x 1486 x 1488]
	Design 3	28 x 33.8 x 49.4 [711 x 859 x 1256]					
Slat crate shipping weight, lbs. [kg]	450 [204]		590 [268]	690 [313]	860 [390]	1385 [628]	1435 [651]
Slat crate shipping volume, ft ³ [m ³]	Design 2	36.2 [1.04]	47 [1.33]	54 [1.52]	78 [2.20]	105 [2.97]	112 [3.17]
	Design 3	38 [1.07]					
Slat crate shipping dimensions (WxDxH), in. [mm]	Design 2	32.5 x 36.8 x 49.8 [826 x 935 x 1240]	36 x 41.3 x 55 [914 x 1049 x 1397]	37 x 45.9 x 55 [940 x 1166 x 1397]	42 x 49.9 x 64 [1067 x 1267 x 1626]	48.5 x 57.5 x 65.1 [1232 x 1461 x 1654]	48.5 x 61.5 x 65.1 [1232 x 1562 x 1654]
	Design 3	32.5 x 36.8 x 55 [826 x 935 x 1397]					
Wash Cylinder Information							
Cylinder diameter, in. [mm]	21 [533]		24 [610]	26.3 [668]	30 [762]	36 [914]	36 [914]
Cylinder depth, in. [mm]	13.8 [350]		16 [406]	20.3 [515]	22 [559]	21.9 [556]	25.9 [657]
Cylinder volume, ft ³ [l]	2.8 [79.3]		4.2 [119]	6.3 [178]	9.00 [255]	12.9 [365]	15.2 [430]

Table 1 *continues...*

Model		20	30	40	60	80	100
Perforation size, in. [mm]		0.188 [4.78]	0.188 [4.78]	0.188 [4.78]	0.188 [4.78]	0.188 [4.78]	0.188 [4.78]
Perforation open area, %		17.3	18.6	18.8	18.8	19.6	20.2
Door Opening Information							
Door opening size, in. [mm]		11.6 [295]	14.3 [363]	16.3 [414]	16.3 [414]	18.5 [470]	18.5 [470]
Height of door bottom above floor, in. [mm]		14.38 [365]	14 [356]	14.56 [370]	14.94 [379]	17.91 [455]	17.91 [455]
Height of door opening above floor, in. [mm]		17 [432]	17 [431]	17.74 [451]	18.12 [460]	20.77 [528]	20.77 [528]
Power Consumption							
Average power used per cycle, kW-hr. (X-voltage shown)	No load	.05	.09	.10	.15	.19	.19
	80 % load	.06	.11	.14	.22	.28	.28
Estimated Building Heat Load							
HVAC load, Btu/hr. [Kcal/hr.] (Non-heat models)		400 [101]	450 [113]	510 [129]	750 [189]	950 [239]	950 [239]
Drive Train Information							
Number of motors in drive train		1	1	1	1	1	1
Drive motor power, hp [kW]		*	2 [1.5]	2 [1.5]	3 [2.2]	5 [3.7]	5 [3.7]
Cylinder Speeds							
Gentle wash/reverse speed, RPM [G]		37 [0.4]	34 [0.4]	33 [0.4]	31 [0.4]	28 [0.4]	28 [0.4]
Wash/reverse speed, RPM [G]		51 [0.8]	48 [0.8]	46 [0.8]	43 [0.8]	39 [0.8]	39 [0.8]
Distribution speed, RPM [G]		92 [2.5]	86 [2.5]	82 [2.5]	77 [2.5]	70 [2.5]	70 [2.5]
Extract Speed 1 (very low), RPM [G]		301 [27]	282 [27]	269 [27]	252 [27]	230 [27]	230 [27]
Extract Speed 2 (low), RPM [G]		518 [80]	485 [80]	464 [80]	434 [80]	396 [80]	396 [80]
Extract Speed 3 (medium), RPM [G]		579 [100]	542 [100]	518 [100]	485 [100]	443 [100]	443 [100]
Extract Speed 4 (high), RPM [G]		648 [120]	606 [120]	579 [120]	542 [120]	495 [120]	495 [125]
Extract Speed 5 (very high), RPM [G]		710 [150]	664 [150]	635 [150]	594 [150]	542 [150]	542 [150]
Extract Speed 6 (ultra high), RPM [G]		819 [200]	766 [200]	733 [200]	686 [200]	626 [200]	568 [165]
Direct Steam Heating (Optional)							
Steam inlet connection size, NPT		1/2	1/2	1/2	1/2	1/2	1/2
Number of steam inlets		**	**	1	1	1	1
Steam required to raise bath water temperature 10°F/lbs. [10°C/kg]	LOW	.74 [0.34]	.94 [0.43]	2.09 [0.94]	3.80 [1.63]	3.80 [1.72]	3.80 [1.72]
	MED	1.07 [0.49]	1.28 [0.58]	2.40 [1.09]	4.65 [2.11]	4.65 [2.11]	5.49 [2.49]
	HIGH	1.44 [0.65]	1.74 [0.79]	2.84 [1.29]	5.79 [2.63]	5.79 [2.63]	6.84 [3.10]

Table 1 continues...

Model		20	30	40	60	80	100
Average steam consumption per cycle, bHP		.34	.41	.78	.98	1.34	1.58
Electrical Heating							
Total electrical heating capacity, kW	Input Voltage						
	200V	5.4	5.4	10.8	10.8	19.1	19.1
	240V	7.8	7.8	15.6	15.6	27.4	27.4
	380V	6.5	6.5	13.0	13.0	17.2	17.2
	415V	7.8	7.8	15.5	15.5	20.5	20.5
	480V	N/A	N/A	15.6	15.6	27.4	27.4
Electrical heating elements		3	3	6	6	6	6
Electrical heat element size, kW		2.6	2.6	2.6	2.6	4.2	4.2
Noise Emissions							
dBA	Wash	58	58	58	58	58	58
	Extract	100G	52	59	59	59	69
		200G	61	66	66	66	76
<p>* For B, Q and X-voltage models = 1 hp [.75 kW] and for N and P-voltage models = 2 hp [1.7 kW]</p> <p>** 20 and 30 models can be prep for steam and a kit is available for conversion.</p> <p>N/A = Not Applicable</p>							

Table 1

Machine Dimensions

20-60 Models

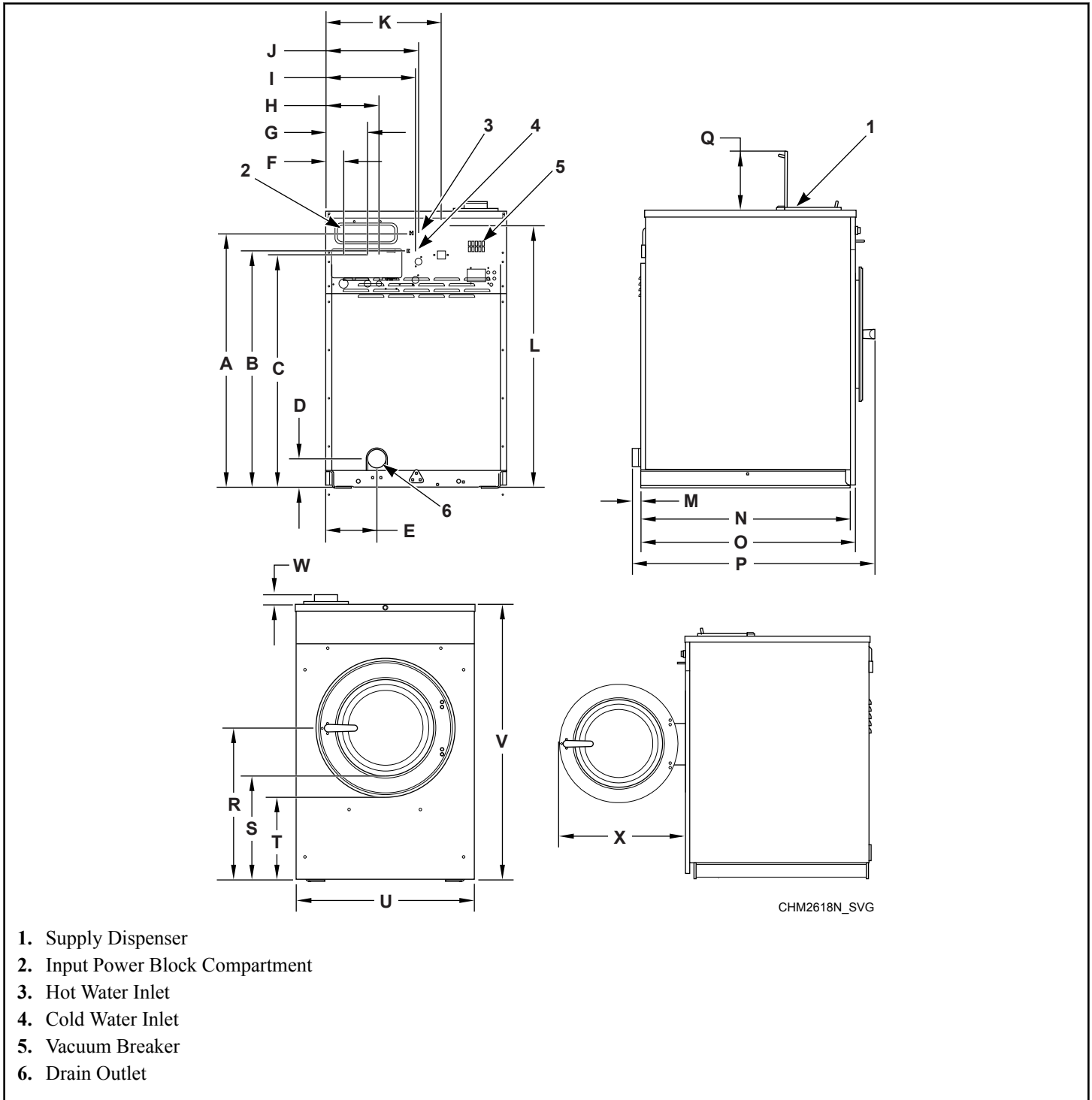
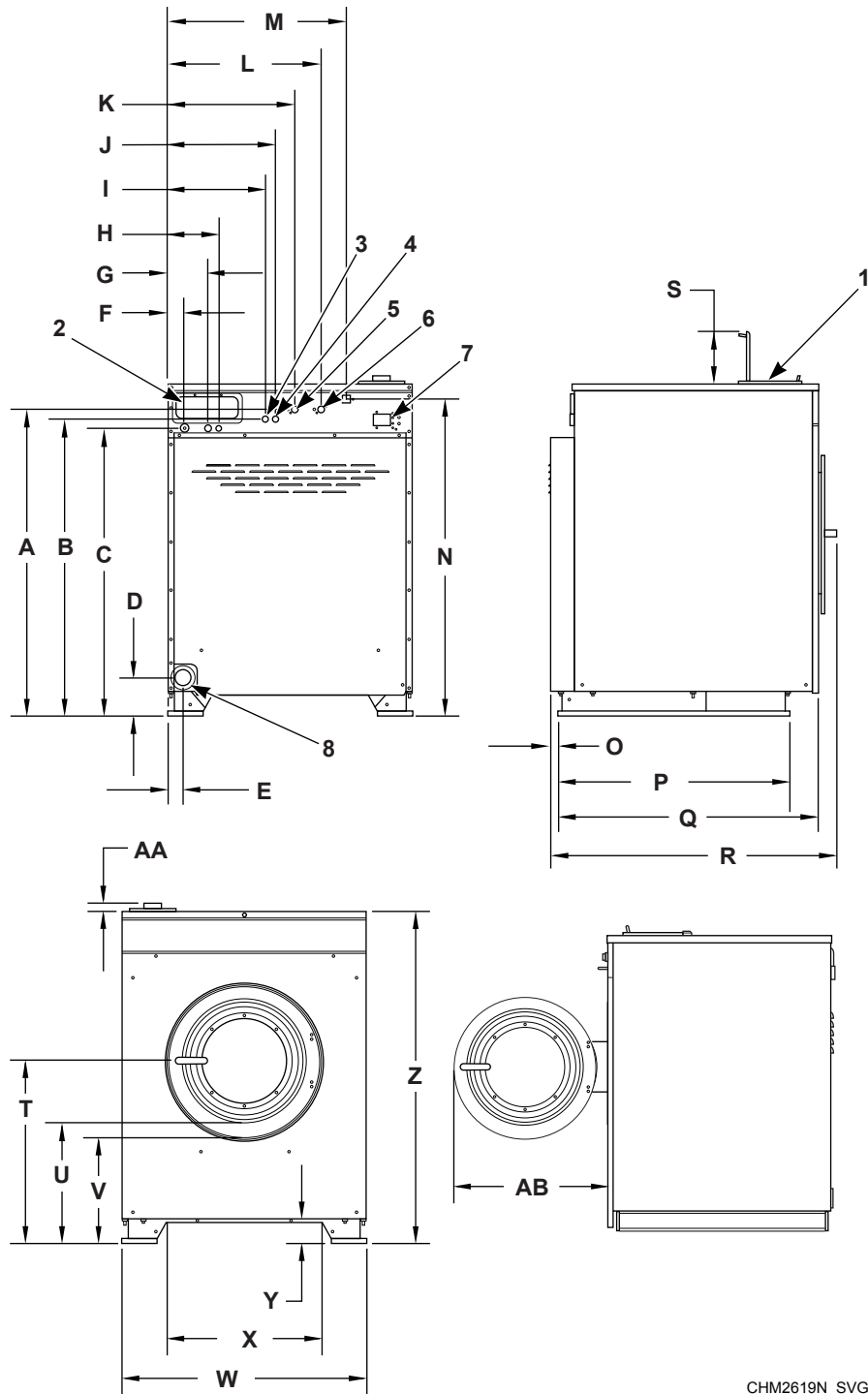

Figure 2

Machine Dimensions - 20-60 Models, in. [mm]					
Specification	20 (Design 2)	20 (Design 3)	30	40	60
A	38.0 [965]	39.0 [991]	40.94 [1040]	43.19 [1097]	45.88 [1165]
B	35.0 [889]	36.0 [914]	37.94 [964]	40.19 [1021]	42.88 [1089]
C	34.52 [902]	35.52 [902]	37.46 [951]	39.71 [1009]	42.4 [1077]
D	4.7 [119]	4.7 [119]	4.14 [105]	4.51 [115]	4.87 [124]
E	7.83 [199]	7.83 [199]	9.33 [237]	8.82 [224]	9.89 [251]
F	2.99 [76]	2.99 [76]	2.99 [76]	2.99 [76]	2.99 [76]
G	6.94 [176]	6.94 [176]	6.94 [176]	6.94 [176]	6.94 [176]
H	8.82 [224]	8.82 [224]	8.82 [224]	8.82 [224]	8.82 [224]
I	15.15 [385]	15.15 [385]	15.15 [385]	15.15 [385]	19.9 [505]
J	15.65 [398]	15.65 [398]	15.65 [398]	15.65 [398]	20.4 [518]
K	N/A	N/A	N/A	19.48 [495]	22.91 [582]
L	N/A	N/A	N/A	44.61 [1133]	47.3 [1201]
M	0.34 [9]	0.34 [9]	0.34 [9]	2.0 [51]	2.0 [51]
N	26.83 [681]	26.83 [681]	31.5 [800]	35.52 [902]	38.62 [981]
O	27.31 [694]	27.31 [694]	31.82 [808]	36.96 [939]	39.45 [1002]
P	30.85 [784]	30.85 [784]	35.29 [896]	42.25 [1073]	44.7 [1135]
Q	9.0 [254]	9.0 [254]	9.0 [254]	9.0 [254]	9.0 [254]
R	23.01 [584]	23.01 [584]	24.0 [610]	26.0 [660]	26.38 [670]
S	17.0 [432]	17.0 [432]	17.0 [432]	17.74 [451]	18.12 [460]
T	14.38 [365]	14.38 [365]	14 [356]	14.56 [370]	14.94 [379]
U	26.0 [660]	26.0 [660]	29.0 [737]	30.63 [778]	34.06 [865]
V	42.0 [1067]	43.0 [1092]	44.95 [1142]	47.2 [1199]	49.89 [1267]
W	1.5 [3]	1.5 [3]	1.5 [38]	1.5 [38]	1.5 [38]
X	16.75 [426]	16.75 [426]	19.38 [429]	21.75 [552]	21.75 [552]
N/A = Not Applicable					

Table 2

80 and 100 Models



CHM2619N_SVG

- 1. Supply Dispenser
- 2. Input Power Block Compartment
- 3. Auxiliary Hot Water Inlet
- 4. Auxiliary Cold Water Inlet
- 5. Cold Water Inlet
- 6. Hot Water Inlet
- 7. Vacuum Breaker
- 8. Drain Outlet

Figure 3

Machine Dimensions - 80 and 100 Models, in. [mm]				
A	51.82 [1316]	O	1.36 [35]	
B	50.32 [1278]	P	39.24 [997]	
C	48.68 [1236]	Q	80	44.16 [1122]
			100	48.16 [1223]
D	6.41 [163]	R	80	48.6 [1234]
			100	52.6 [1336]
E	2.55 [65]	S	9.0 [229]	
F	2.99 [76]	T	30.91 [785]	
G	6.94 [176]	U	20.77 [528]	
H	8.82 [224]	V	17.91 [455]	
I	16.66 [423]	W	41.5 [1054]	
J	18.18 [462]	X	26.15 [664]	
K	21.65 [550]	Y	3.57 [91]	
L	26.15 [664]	Z	56.16 [1426]	
M	30.35 [771]	AA	1.5 [38]	
N	53.57 [1361]	AB	25.25 [641]	

Table 3

Mounting Bolt Hole Locations – 20 and 30 Models

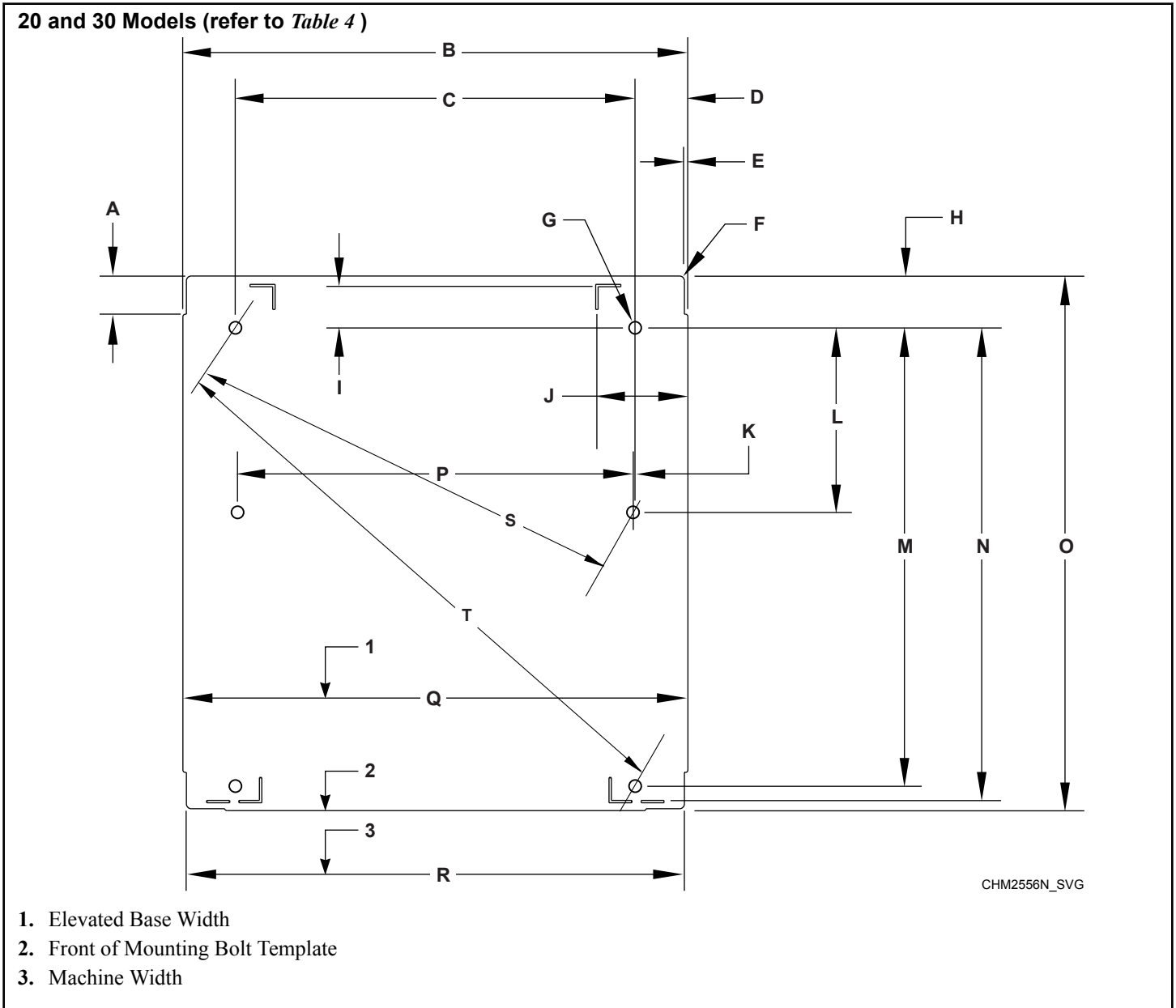

Figure 4

Mounting Bolt Hole Locations – 20 and 30 Models, in. [mm]		
Specification	20	30
A	2 [51]	2 [51]
B	26.37 [670]	29.38 [746]
C	20.88 [530]	23.89 [607]

Table 4 continues...

Mounting Bolt Hole Locations – 20 and 30 Models, in. [mm]		
Specification	20	30
D	2.75 [70]	2.75 [70]
E	0.18 [5]	0.18 [5]
F	0.25 [6]	0.25 [6]
G	0.64 [16]	0.64 [16]
H	2.71 [69]	2.37 [60]
I	2.15 [55]	1.81 [46]
J	4.69 [119]	4.69 [119]
K	0.19 [5]	0.19 [5]
L	9.64 [245]	10.5 [267]
M	23.94 [608]	28.94 [735]
N	24.69 [627]	29.69 [754]
O	27.92 [709]	32.59 [828]
P	20.65 [524]	23.5 [597]
Q	26.37 [670]	29.38 [746]
R	26 [660]	29.02 [737]
S	22.2 [564]	26.1 [663]
T	31.19 [792]	37.53 [953]

Table 4

Mounting Bolt Hole Locations - 40 and 60 Models

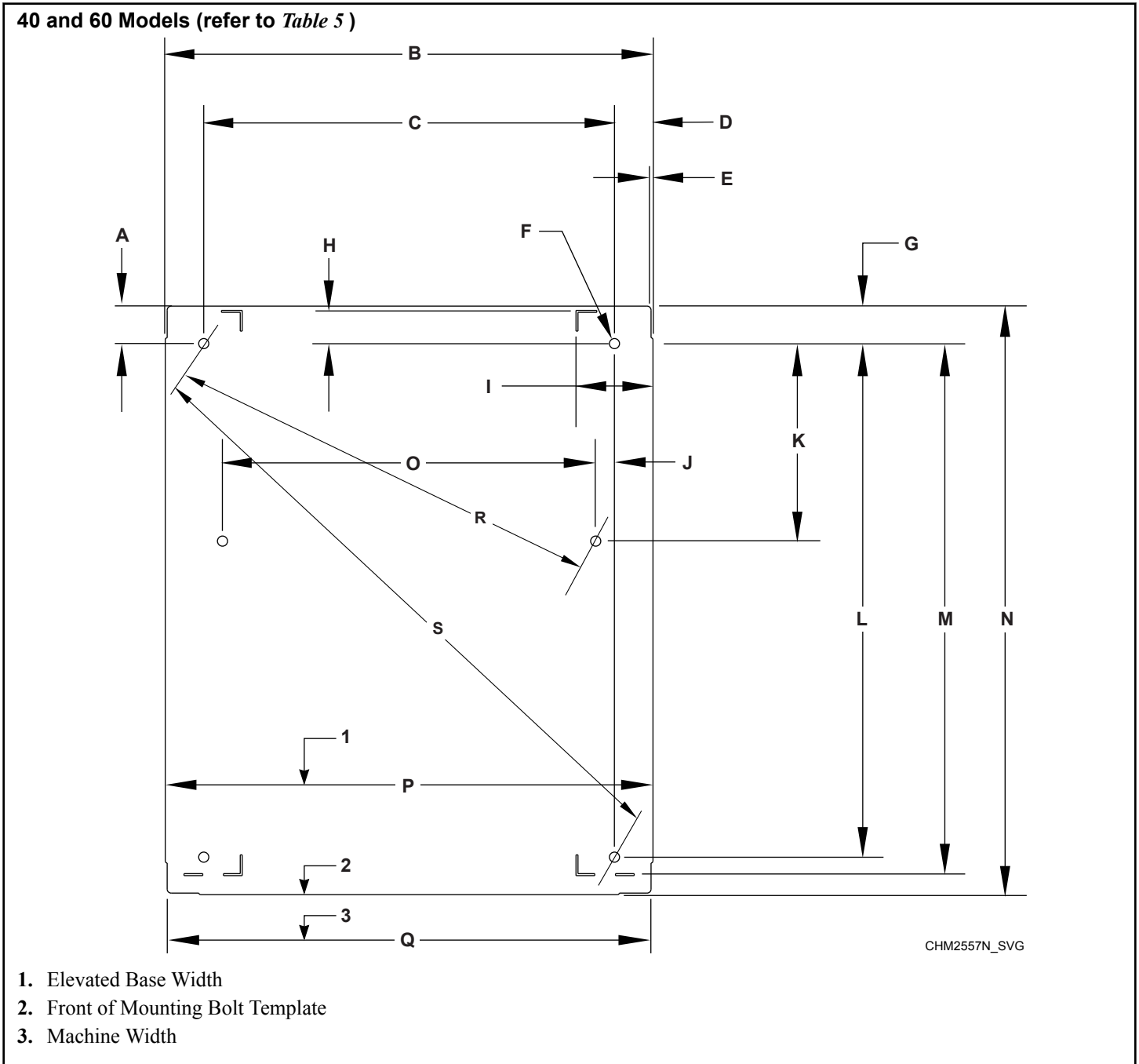

Figure 5

Mounting Bolt Hole Locations - 40 and 60 Models, in. [mm]		
Specification	40	60
A	2 [51]	2 [51]

Table 5 continues...

Mounting Bolt Hole Locations - 40 and 60 Models, in. [mm]		
Specification	40	60
B	30.88 [784]	34.44 [875]
C	26 [660]	30 [762]
D	2.44 [62]	2.22 [56]
E	0.12 [3]	0.12 [3]
F	0.64 [16]	0.64 [16]
G	2.37 [60]	2.37 [60]
H	2 [51]	1.75 [44]
I	4.75 [121]	5.15 [131]
J	1.19 [30]	1.25 [32]
K	12.5 [318]	11.93 [303]
L	32.5 [826]	36 [914]
M	33.54 [852]	36.87 [936]
N	37.25 [946]	40.5 [1029]
O	23.63 [600]	27.5 [699]
P	30.88 [784]	34.44 [875]
Q	30.63 [778]	34.19 [868]
R	28.85 [733]	32.29 [820]
S	41.62 [1057]	46.86 [1190]

Table 5

Mounting Bolt Hole Locations – 80 and 100 Models

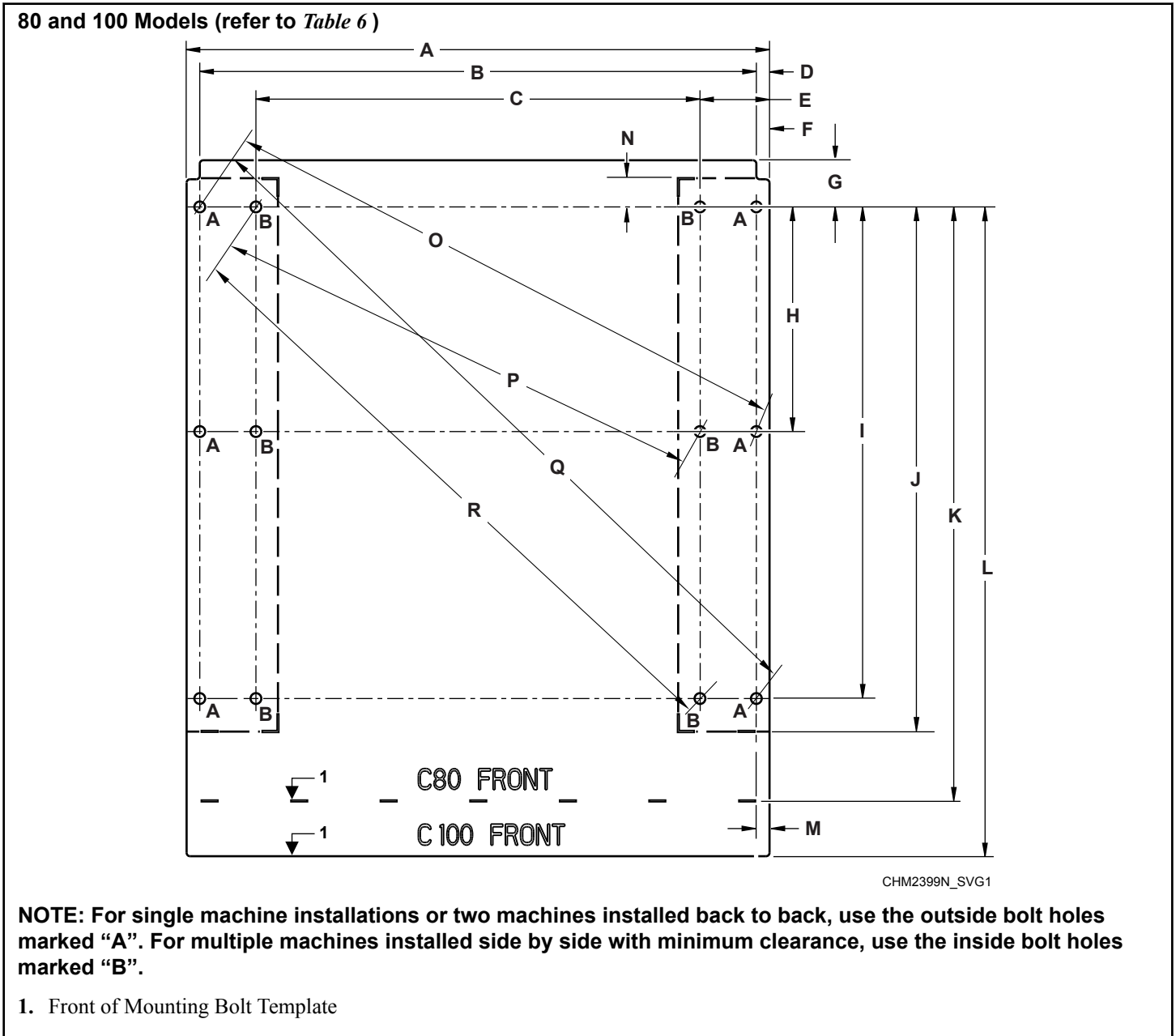

Figure 6

Mounting Bolt Hole Locations – 80 and 100 Models, in. [mm]		
Specification	80	100
A	41.5 [1054]	41.5 [1054]
B	39.62 [1006]	39.62 [1006]
C	31.62 [803]	31.62 [803]

Table 6 continues...

Mounting Bolt Hole Locations – 80 and 100 Models, in. [mm]		
Specification	80	100
D	.94 [24]	.94 [24]
E	4.94 [124]	4.94 [124]
F	6.63 [164]	6.63 [164]
G	3.3 [84]	3.3 [84]
H	16 [406]	16 [406]
I	35 [889]	35 [889]
J	37.3 [947]	37.3 [947]
K	42.2 [1073]	N/A
L	N/A	46.2 [1260]
M	1 [25]	1 [25]
N	1.96 [50]	1.96 [50]
O	Outside	42.72 [1085]
P	Inside	35.43 [900]
Q	Outside	52.86 [1342]
R	Inside	47.16 [1197]
N/A = Not Applicable		

Table 6

Floor Mounting Layout – 20-60 Models

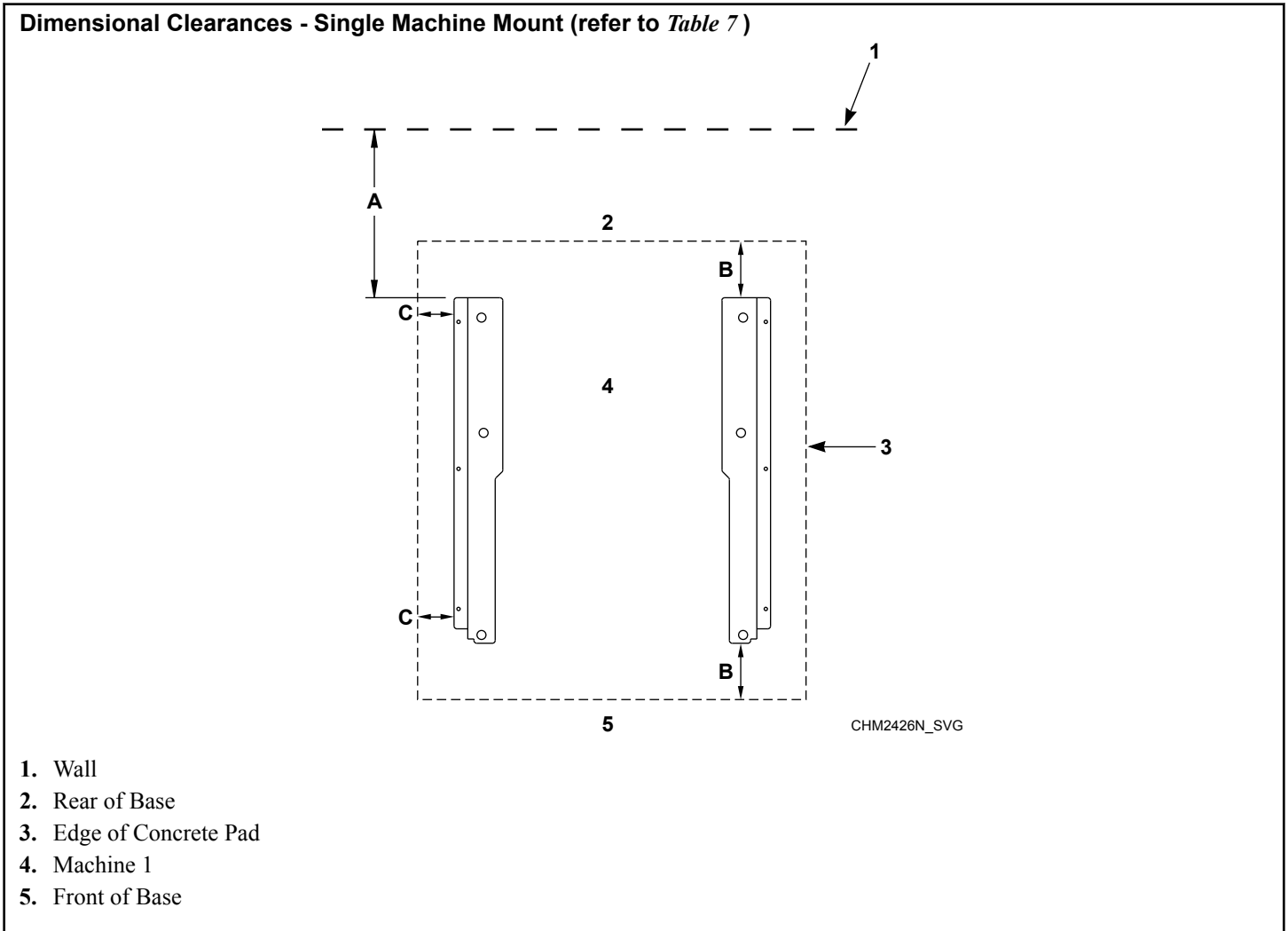

Figure 7

Dimensional Clearances - Single Machine Mount - 20-60 Models, in. [mm]					
Description		20	30	40	60
A	Distance to wall (minimum)	24 [610]	24 [610]	24 [610]	24 [610]
B	Distance of machine base to edge of pad (minimum)	3.44 [87]	4 [102]	3.99 [101]	5.99 [152]
C	Distance of machine base to edge of pad (minimum)	2.52 [64]	2.51 [64]	2.81 [71]	5.18 [131]

Table 7

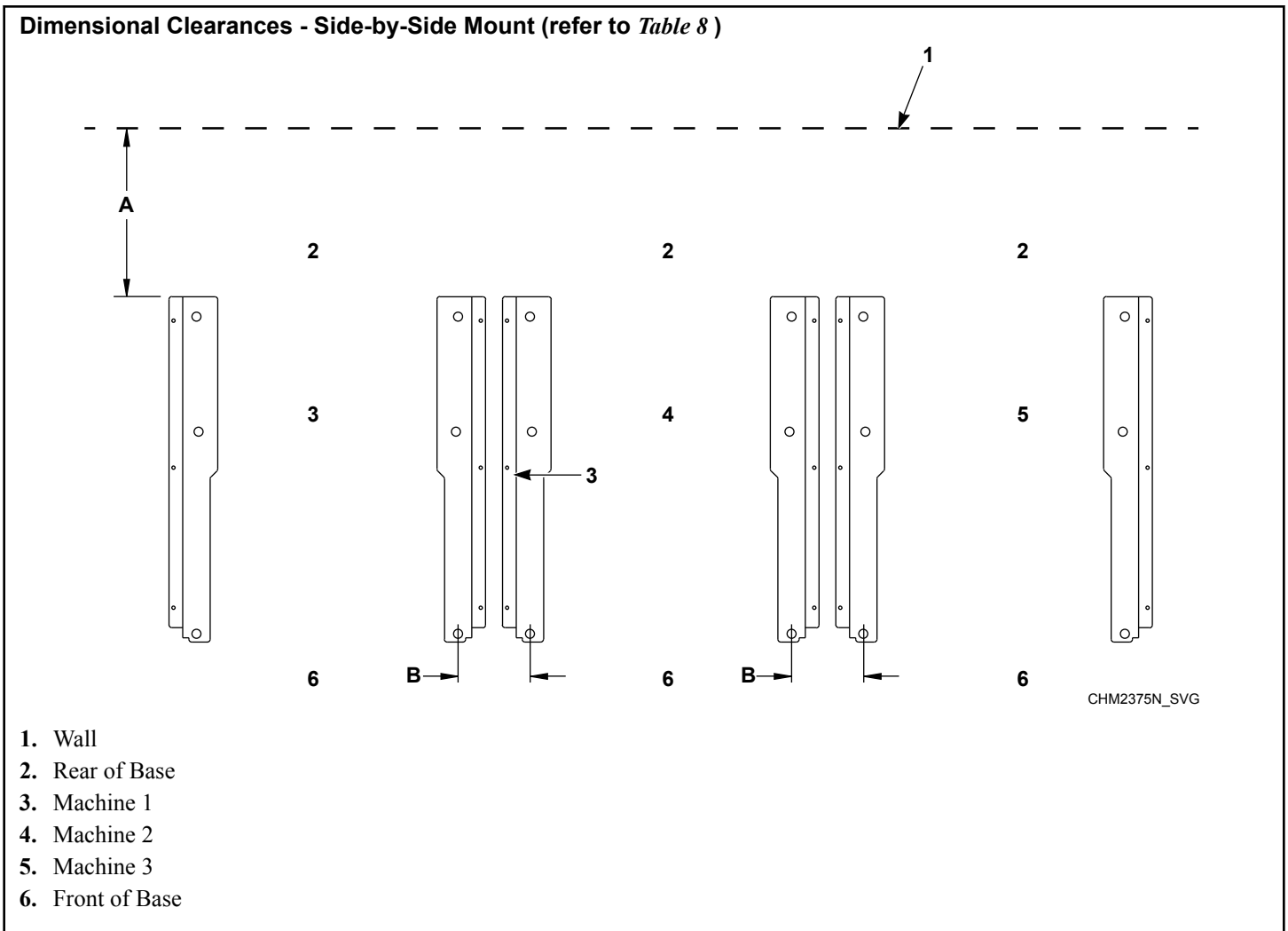

Figure 8

Dimensional Clearances - Side-by-Side Mount - 20-60 Models, in. [mm]					
Description		20	30	40	60
A	Distance to wall (minimum)	24 [610]	24 [610]	24 [610]	24 [610]
B	Mounted without bases (minimum)	5.14 [131]	5.12 [130]	4.63 [118]	4.06 [103]
	Mounted with bases (minimum)	5.5 [139]	5.5 [139]	4.88 [124]	4.44 [112]

Table 8

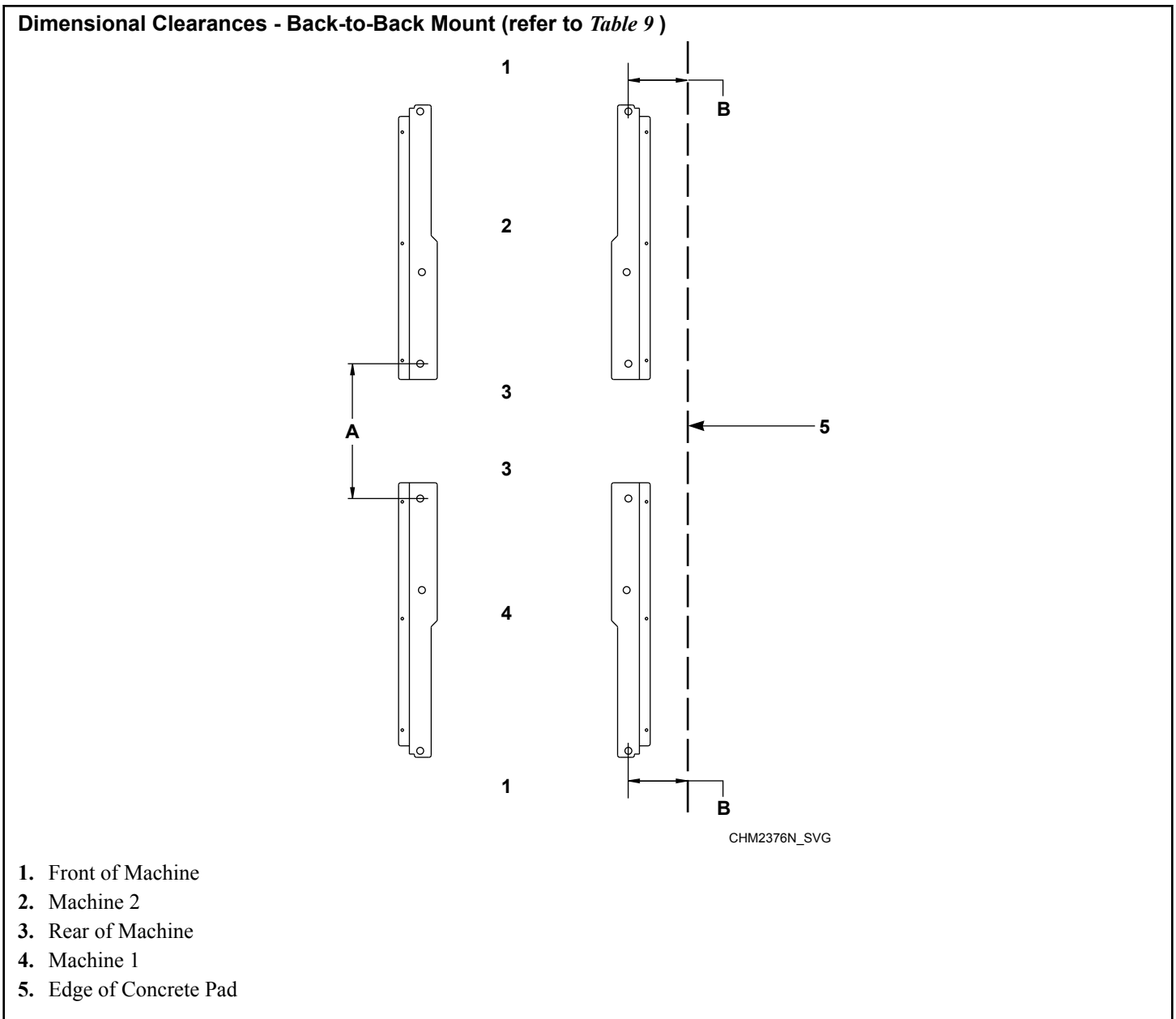

Figure 9

Dimensional Clearances - Back-to-Back Mount - 20-60 Models, in. [mm]					
Description		20	30	40	60
A	Adjacent rear bolt spacing (minimum)	28.3 [719]	27.6 [702]	28.0 [710]	27.5 [699]
B	Distance from front bolt to edge of pad (minimum)	5.26 [134]	5.26 [134]	6.19 [157]	8.9 [226]

Table 9

Floor Mounting Layout – 80 and 100 Models

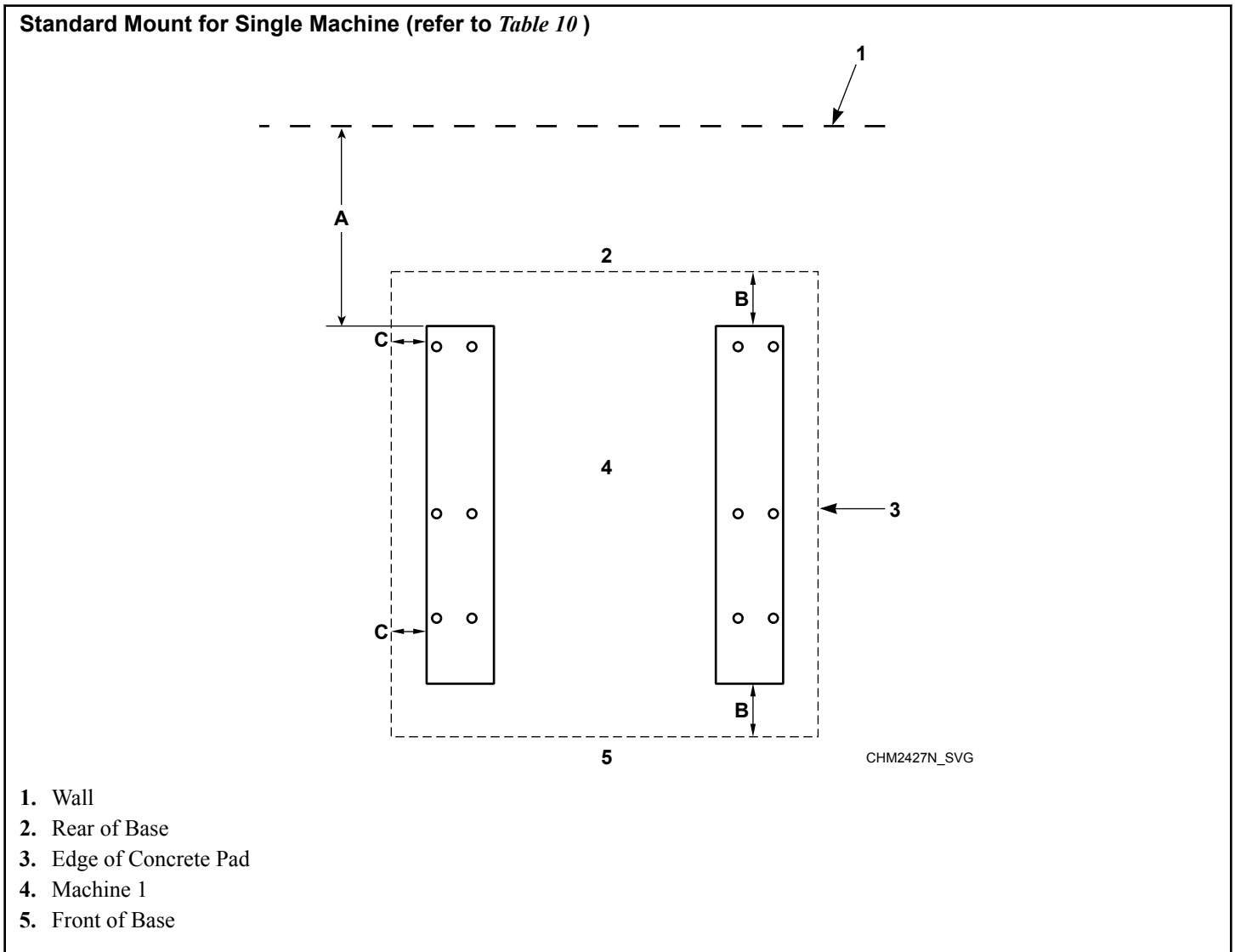

Figure 10

Standard Mount for Single Machine - 80 and 100 Models, in. [mm]		
Description		80-100
A	Distance to wall (minimum)	24 [610]
B	Distance of machine base to edge of pad (minimum)	4.98 [126]
C	Distance of machine base to edge of pad (minimum)	8 [203]

Table 10

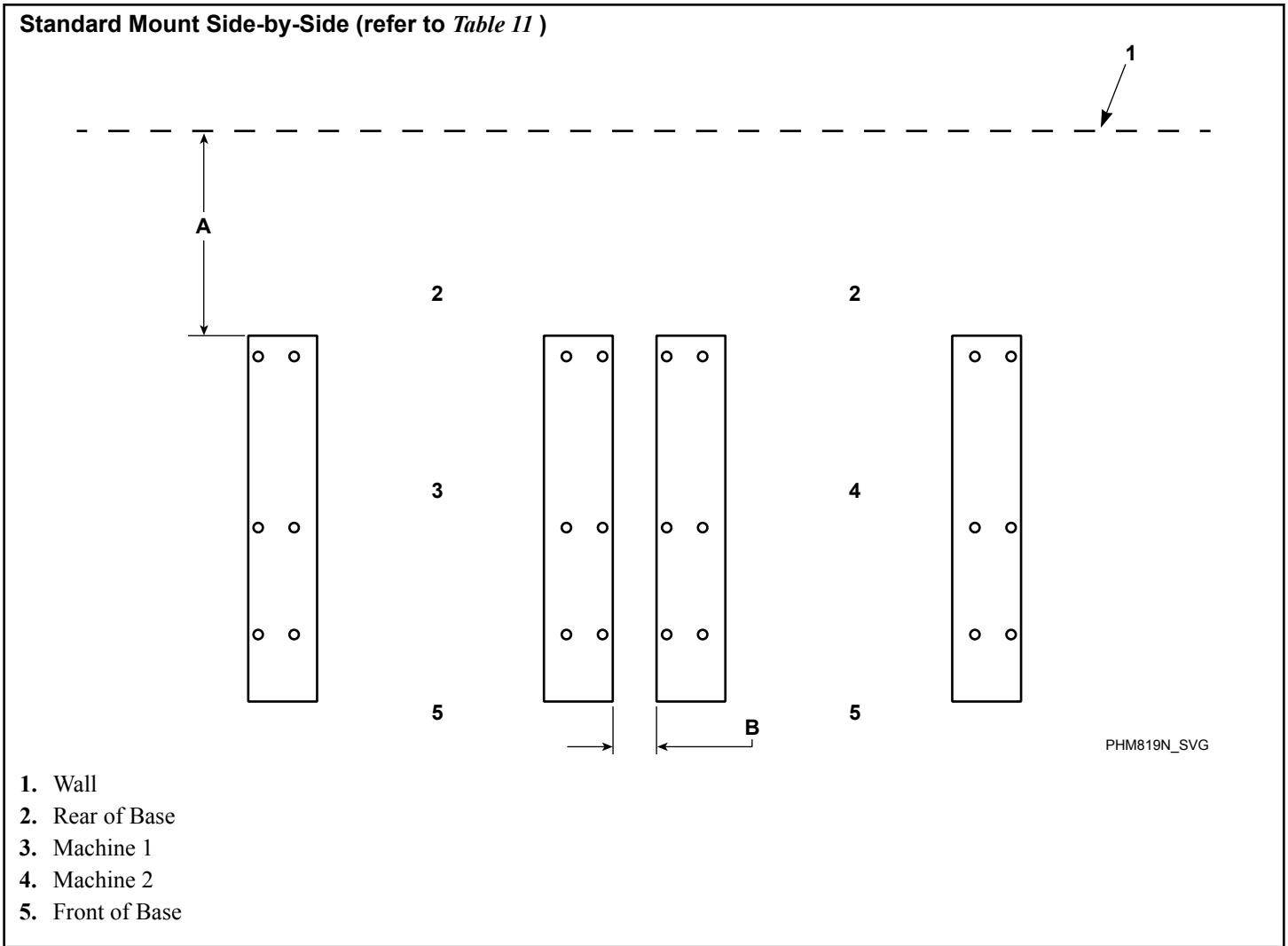

Figure 11

Standard Mount Side-by-Side - 80 and 100 Models, in. [mm]		
Description		80-100
A	Distance to wall (minimum)	24 [610]
B	Adjacent unit bolt spacing (minimum)	6 [152]

Table 11

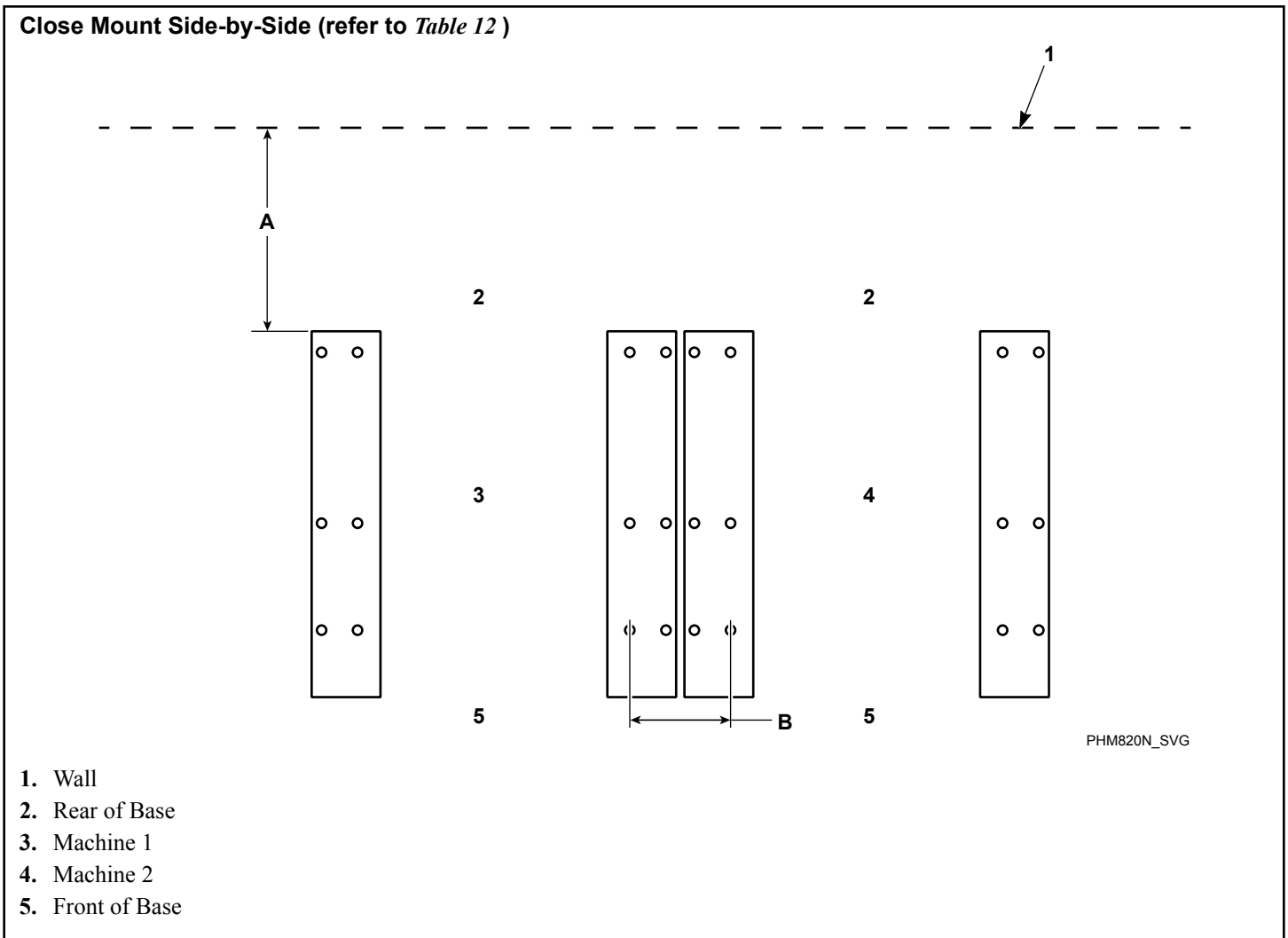
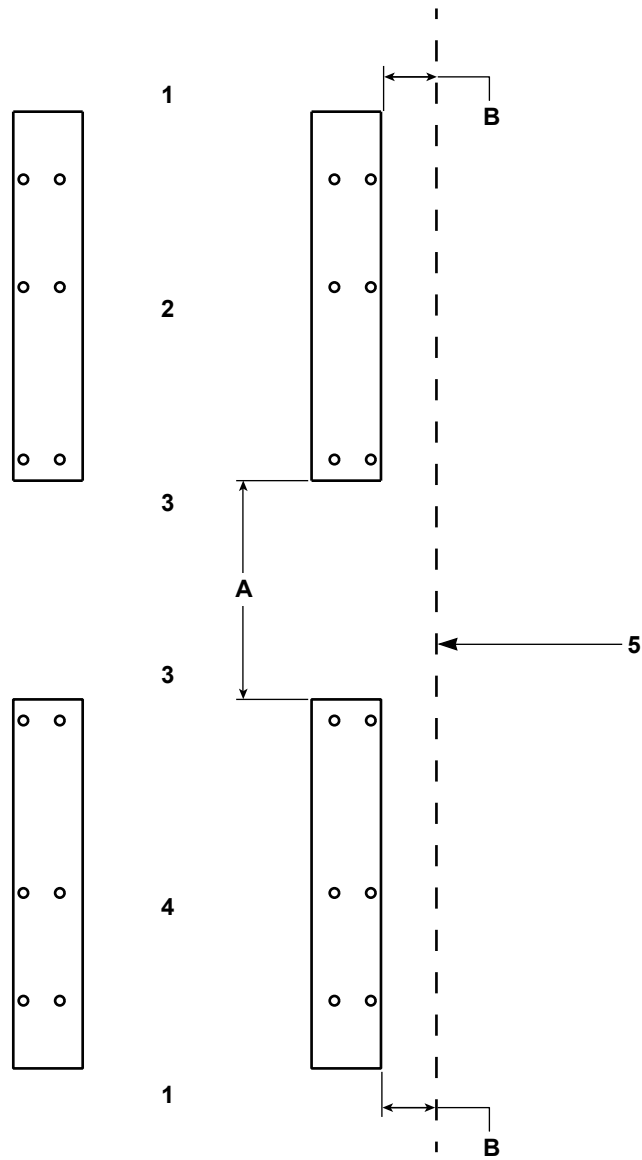

Figure 12

Close Mount Side-by-Side - 80 and 100 Models, in. [mm]		
Description		80-100
A	Distance to wall (minimum)	24 [610]
B	Adjacent unit bolt spacing (minimum)	10.38 [264]
IMPORTANT: When close mounting, bolt machine using inside bolt holes.		

Table 12

Back-to-Back Mount (refer to *Table 13*)



PHM810N_SVG

- 1. Front of Machine
- 2. Machine 2
- 3. Rear of Machine
- 4. Machine 1
- 5. Edge of Concrete Pad

Figure 13

Back-to-Back Mount - 80 and 100 Models, in. [mm]		
Description		80-100
A	Adjacent rear bolt spacing (minimum)	33.3 [846]
B	Distance from front bolt to edge of pad (minimum)	8 [203]

Table 13

Installation

Pallet Jack Cover Plate Removal (80 and 100 Models Only)

Prior to installing an 80 and 100 models, the optional pallet jack cover plate can be removed in preparation of re-installing to machine base frame after machine installation.

1. Locate cover plate on back panel.
2. Remove back panel.
3. Remove all hardware holding cover plate on back panel, refer to *Figure 14*. **DO NOT DISCARD HARDWARE.**
4. Remove cover plate.

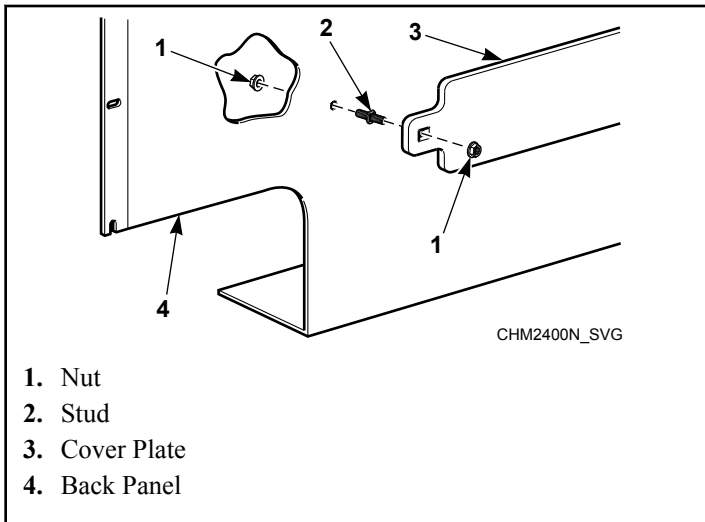

1. Nut
2. Stud
3. Cover Plate
4. Back Panel

Figure 14

5. Re-install back panel.

NOTE: Refer to *Pallet Jack cover Plate Installation (80 and 100 Models Only)* section to install cover plate to machine base after machine installation.

Single Machine Foundation Requirements

A minimum 3500 psi (refer to rating per supplier) reinforced concrete set on a prepared bed is required for all new machine installations.

NOTE: Do not mount on wooden floors, tile floors, elevated floor levels, stacked multiple base frames, or over basements or crawl spaces because of the high extract speed and the G-forces exerted. For 80 models and larger, do not mount on metal base frames.

Thoroughness of detail must be stressed with all foundation work to ensure a stable unit installation, eliminating possibilities of excessive vibration during extract.



WARNING

To reduce the risk of fire, serious injury, property damage and/or death, install the machine on a level (within 3/8 inch), uncovered concrete floor of sufficient strength at grade.

W787

For new foundations a mounting bolt template or an elevated metal base frame is available at extra cost. For all installations a concrete hardware kit is available at extra cost.

The machine must be anchored to a smooth level surface so that the entire base of the machine is supported and rests on the mounting surface.

IMPORTANT: Do not permanently support the machine on only four points with spacers. Grouting is required and spacers must be removed.

Machine Installation with Existing Floor

The existing floor slab must meet minimum requirements shown in *Machine Foundation and Pad Installation* per machine model. The floor must be reinforced concrete without voids under slab. If the floor meets these requirements and an elevated pad is NOT desired, refer to *Figure 16* and proceed to *Machine Mounting and Grouting* section.

Elevated Pad Installation with Existing Floor

The existing floor slab must meet minimum requirements shown in *Machine Foundation and Pad Installation* per machine. The floor must be reinforced concrete without voids under slab. If the slab meets these requirements and an elevated pad is desired, refer to *Figure 17* and proceed to *Machine Foundation and Pad Installation* section.

Elevated Base Frame Installation with Existing Floor

The existing floor slab must meet minimum requirements shown in *Machine Foundation and Pad Installation* per machine. The floor must be reinforced concrete without voids under slab. If the slab meets these requirements and an elevated base frame is desired, refer to *Figure 17* and *Figure 18* and proceed to *Machine Mounting and Grouting*.

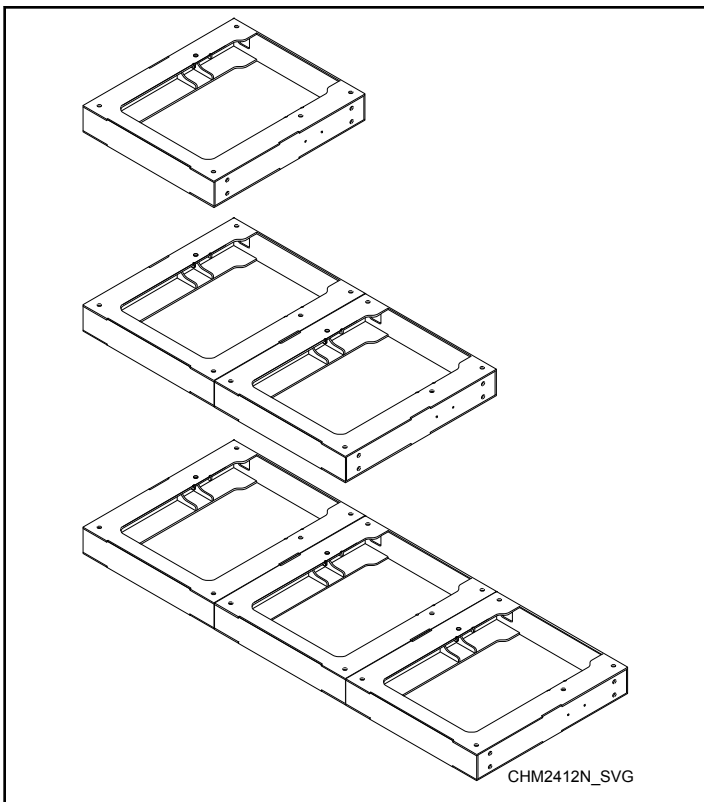

Figure 15

New Foundation

If the existing floor slab does not meet the single machine foundation requirements per model, refer to *Figure 18* and proceed to *Machine Foundation and Pad Installation* section.

Isolated Pad Installation

This type of installation is NOT recommended. Installer MUST consult a Structural Engineer for concrete specifications and requirements for installations that will not be tied into adjacent foundations.

IMPORTANT: The above instructions and recommendations are conservative specifications for a typical installation based on consultations with a structural engineer. Alliance Laundry Systems stands behind all installations meeting these specifications. For alternate installation specifications based on your soil type, location, building structure, unique floor geometry, machine types, and utilities, consult a structural engineer in your local area.

Machine Foundation and Pad Installation

A concrete pad may be constructed to elevate a machine. Care must be exercised in the design of the pad due to the force exer-

ted by the machine during extract. This concrete pad, recommended not to exceed 8 inches [203 mm] above existing floor, must be placed, reinforced with rebar and tied to the existing floor. Refer to *Table 14*, *Figure 16*, *Figure 17* and *Figure 18* for multiple machine installations.

Machine Foundation and Pad Installation, in. [mm]						
Specification		20	30	40	60	80-100
Minimum Foundation Thickness	F-speed	4 [102]	4 [102]	4 [102]	4 [102]	6 [152]
	V-speed			6 [152]	6 [152]	9 [229]
Minimum Excavation Depth	F-speed	8 [203]	8 [203]	8 [203]	8 [203]	12 [305]
	V-speed			12 [305]	12 [305]	15 [381]
Minimum Pad Size						
Single machine (WxD)		31.4 x 34.8 [798 x 884]	34.4 x 39.5 [874 x 1003]	36.5 x 43.5 [927 x 1105]	44.8 x 50.6 [1139 x 1285]	57.5 x 49.2 [1461 x 1250]
Two machines, Side-by-side (WxD)		57.54 x 34.8 [1462 x 884]	63.52 x 39.5 [1613 x 1003]	67.38 x 43.5 [1711 x 1105]	78.98 x 50.6 [2006 x 1285]	99.5 x 49.2 [2527 x 1250]
Two machines, Back-to-back (WxD)		31.4 x 88.63 [798 x 2251]	34.4 x 98.37 [874 x 2499]	36.5 x 115.23 [927 x 2927]	44.8 x 119.48 [1138 x 3035]	51.5 x 130.56 [1308 x 3316]
NOTE: Inside and outside mounting only available on 80 and 100 models.						
N/A = Not Applicable						

Table 14

IMPORTANT: Do NOT install a pad on top of the existing floor. The foundation and pad must be constructed and tied together as one piece.

If the existing floor is not reinforced concrete at least of minimum thickness (depending on model), an elevated pad is desired or multiple machines are to be installed, the following steps must be performed (refer to *Figure 16*, *Figure 17* and *Figure 18*):

1. Cut a hole larger on all sides than the machine base through the existing floor, refer to *Table 14*.
2. Excavate to a depth as indicated in *Table 14* from the top of the existing floor.
3. If installing a foundation with elevated pad, prepare a form for the above-ground portion of the foundation. Verify that the top of the foundation is level. The height of the foundation pad must not exceed 8 inches [203 mm] above the existing floor.
4. Backfill with clean fill dirt.
5. Compact backfill, making sure to allow for correct concrete thickness.
6. Drill holes [refer to manufacturer’s requirements for drill hole size] for the perimeter reinforcing bar at a depth of 2.5 inches [64 mm] into the existing floor. The reinforcing should be 12 inches [305 mm] on center each way around entire perimeter.

7. Clean out debris from each reinforcing bar hole.
8. Fill half the hole depth with acrylic adhesive.
9. Using #4 (60 ksi) reinforcing bar, tie new pad to existing floor making sure to tie reinforcing bars at the intersections and using proper reinforcing bar supports to hold bars at the proper depth in the pad.
10. Allow adhesive around reinforcing bar to cure properly, refer to adhesive manufacturer for recommended cure times.
11. Completely fill with 3500 psi minimum concrete up to the existing foundation level plus any added level (maximum of 8 inches [203 mm]) for the desired elevated pad. The concrete must be poured so that the entire foundation and pad cures as one piece.
12. Allow concrete to cure, refer to manufacturer’s recommended cure times.
13. Using a mounting bolt template, elevated base frame or the machine base, mark where the holes should be drilled to mount the machine.

NOTE: As an alternate method, cast in the Grade 5 (minimum SAE rating), 5/8 inches [16 mm] for 20-60 models and 3/4 inch [19 mm] for 80 and 100 models anchor bolts as the concrete is poured, refer to *Figure 20* and *Table 18*.

14. Proceed to *Machine Mounting and Grouting* section.

Machine Installation

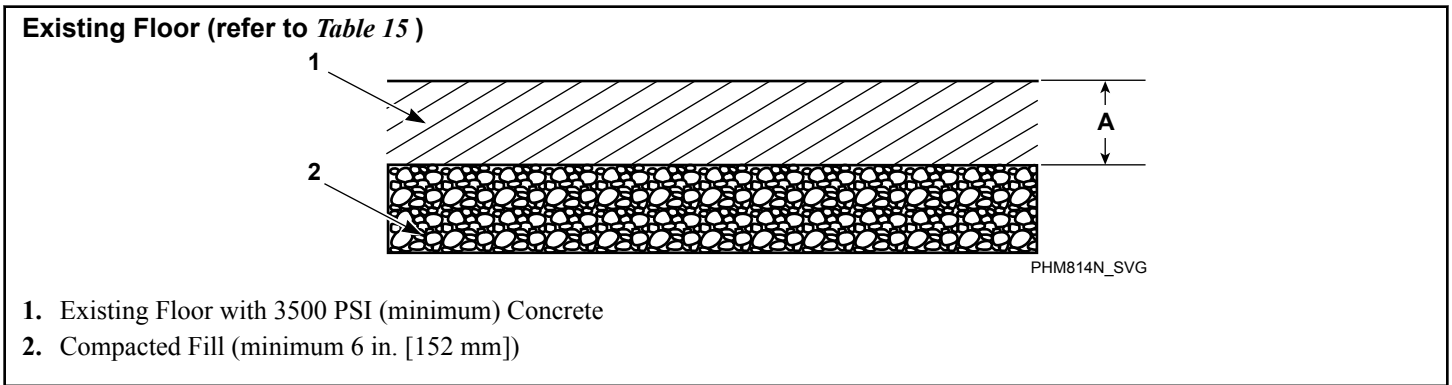

Figure 16

		Existing Floor, in. [mm]			
Description		20-30	40-60 (F-speed)	40-60 (V-speed)	80-100
A	Required thickness of existing floor (minimum)	4 [102]	4 [102]	6 [152]	9 [229]

Table 15

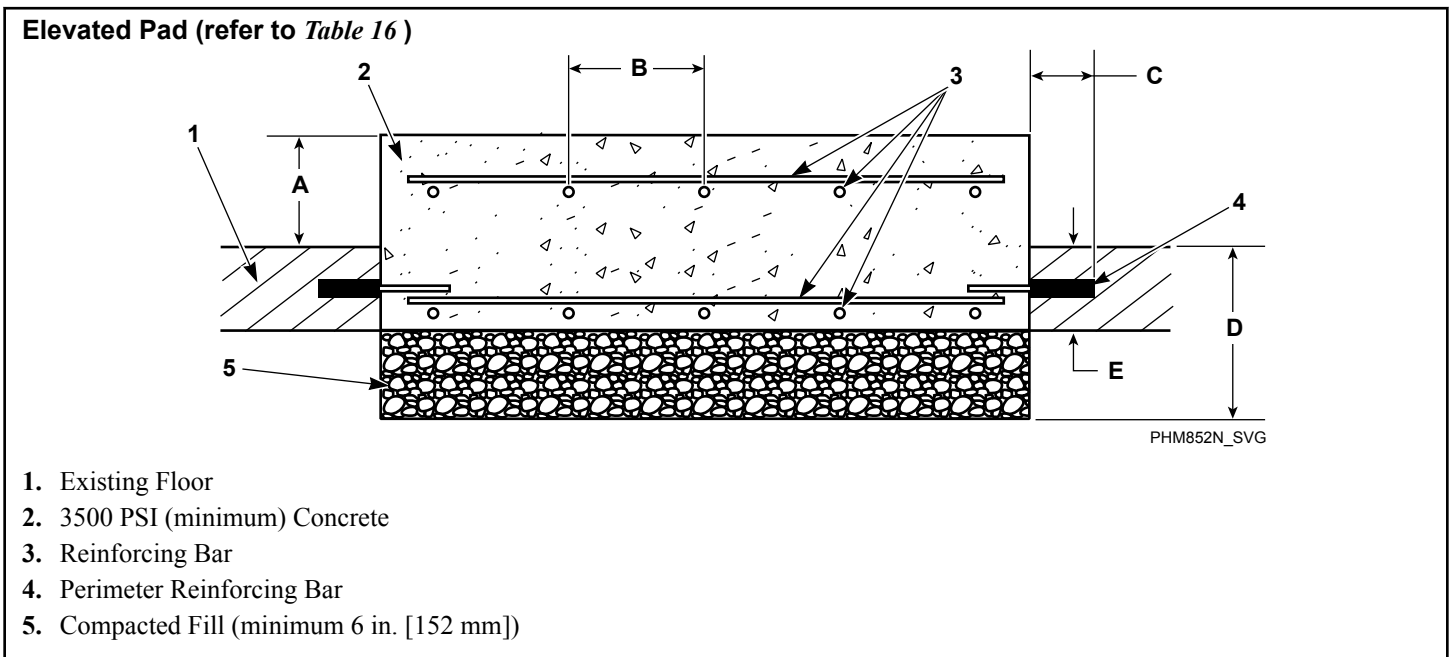

Figure 17

Elevated Pad, in. [mm]					
Description		20-30	40-60 (F-speed)	40-60 (V-speed)	80-100
A	Height of elevated pad above floor (maximum)	8 [203]	8 [203]	8 [203]	8 [203]
B	Distance between reinforcing bars (maximum)	12 [305]	12 [305]	12 [305]	12 [305]
C	Length of reinforcing bar extending in- to existing floor (minimum)	2.5 [64]	2.5 [64]	2.5 [64]	2.5 [64]
D	Total depth of foundation (concrete plus 6 in. [152 mm] fill) (minimum)	8 [203]	8 [203]	12 [305]	15 [381]
E	Required thickness of existing floor (minimum)	4 [102]	4 [102]	6 [152]	6 [152]

Table 16

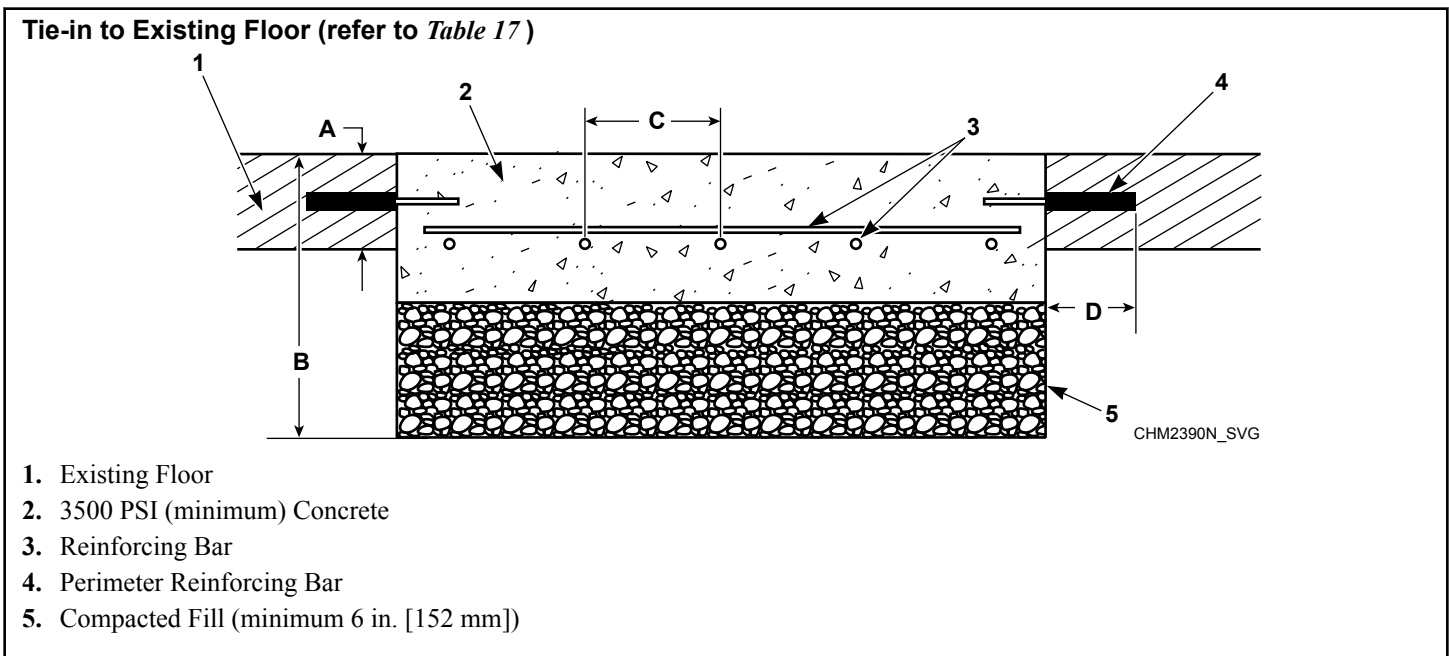

Figure 18

Tie-in to Existing Floor, in. [mm]					
Description		20-30	40-60 (F-speed)	40-60 (V-speed)	80-100
A	Required thickness of existing floor (minimum)	4 [102]	4 [102]	6 [152]	6 [152]

Table 17 continues...

Tie-in to Existing Floor, in. [mm]					
Description		20-30	40-60 (F-speed)	40-60 (V-speed)	80-100
B	Total depth of foundation (concrete plus 6 in. [152 mm] fill)(minimum)	8 [203]	8 [203]	12 [305]	15 [381]
C	Distance between reinforcing bars (minimum)	12 [305]	12 [305]	12 [305]	12 [305]
D	Length of reinforcing bar extending into existing floor (minimum)	2.5 [64]	2.5 [64]	2.5 [64]	2.5 [64]

Table 17

Machine Mounting and Grouting

NOTE: After the concrete has cured completely and the cast-in-place method was used, refer to *Figure 20* and proceed to Step 7. If acrylic adhesive anchors are desired, refer to *Figure 19* and proceed with Step 1 after concrete has cured completely.

1. Refer to *Table 18* to set the drill depth gauge.
2. Drill the holes to the set depth.
3. Use compressed air or squeeze bulb to clean out debris from each hole.
4. Fill half the hole depth with an industry-accepted adhesive anchoring system.
5. Insert anchor bolt until it reaches the bottom. Refer to *Table 18*.
6. Ensure all air pockets are removed from adhesive surrounding the bolt.
7. Allow adhesive around bolt to cure completely.
8. Remove shipping materials and place the machine or elevated base frame carefully over the bolts.

NOTE: Never attempt to lift the machine by the door handle or by pushing on the cover panels. Always insert a pry bar or other lifting device under the bottom frame of the machine to move it.

IMPORTANT: DO NOT install 80 or larger models on an elevated metal base frame.
9. Raise and level the machine or elevated base frame 1/2 inch [1.27 cm] off the floor on four corners, using spacers such as nut fasteners.



WARNING

Crush hazard. To avoid personal injury and/or property damage, do not tip the machine more than 25 degrees in any direction.

W793

10. Completely fill the space between the elevated base frame or machine base and the floor with a good quality **non-shrink-ing machinery precision grout** to ensure a stable installation. Grout completely under frame. Remove front panel and back panel to gain access to **entire perimeter of base plates**. Force grout under base until all voids are filled.

IMPORTANT: Minimum Grade 5, SAE rating, flat washers and minimum Grade 5, SAE rating, serrated hex flange locknuts are the recommended hardware for anchoring machine or elevated base frame to anchor bolts.
 11. Position the flat washers and locknuts on the anchor bolts and finger-tighten to machine base or elevated base frame.
 12. Allow machine grout to set, but not cure.

IMPORTANT: Refer to bolt manufacturer's recommended adhesive cure times.
 13. Remove the spacers carefully, allowing the machine base or elevated base frame to settle into the wet grout.

NOTE: If installing a 20 through 60 model directly to finished floor, wait until grout is completely cured and skip to Step 18. If installing on elevated base frame, proceed to Step 14.
- 20-60 Models**
14. After the grout is completely cured, position the machine over the elevated base frame.
 15. Align the mounting holes on the machine with the corresponding holes on the elevated base frame.
 16. Install a bolt, flat washer and locknut in each mounting hole.
 17. Hand tighten each nut.

Installation

- a. Tighten the two rear nuts two turns.
 - b. Tighten the two front nuts two turns.
 - c. Tighten the two middle nuts firmly.
18. Torque all the locknuts to 90 ± 9 ft.-lbs. – one after the other – until all are tightened evenly and the machine is fastened securely to the elevated base frame or floor.

IMPORTANT: Refer to recommended grout cure times from manufacturer before torquing locknuts.

IMPORTANT: All torque joints must remain dry (non-lubricated).

NOTE: Check and retighten the locknuts after five to ten days of operation and every month thereafter.

80 and Larger Models

19. After the grout is completely cured, torque the locknuts to 150 ± 15 ft.-lbs. – one after the other – until all are tightened evenly and the machine is fastened securely to the floor.

Acrylic Adhesive Anchors (refer to *Table 18*)

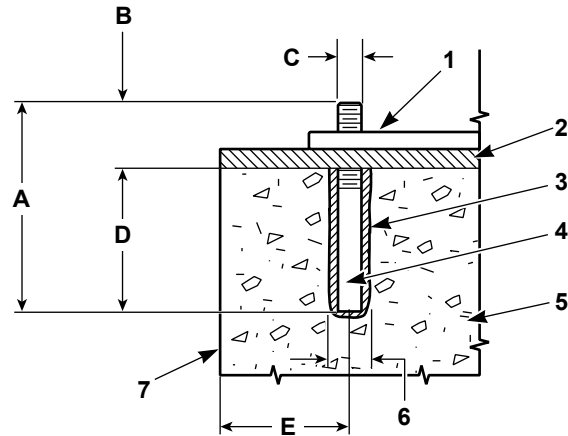

PHM811N_SVG

1. Machine Frame Base
2. Grout 1/2 in. [13 mm]
3. Acrylic Adhesive
4. Anchor Bolt (minimum Grade 5 SAE rating)
5. Concrete
6. Drill Hole Size per Manufacturer Requirements
7. Edge of Pad

Figure 19

Cast-in-place Anchors (refer to Table 18)

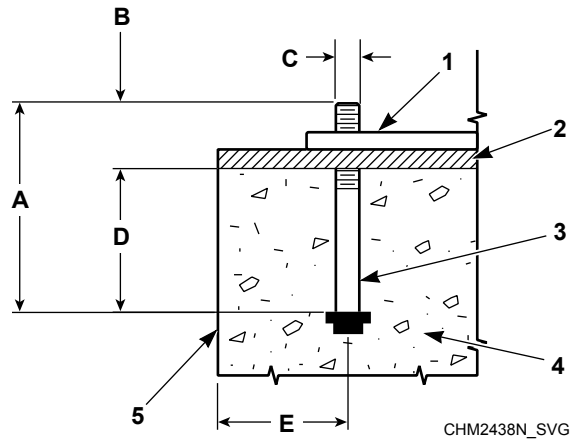

- 1. Machine Frame Base
- 2. Grout
- 3. Anchor Bolt (minimum Grade 5 SAE rating)
- 4. Concrete
- 5. Edge of Pad

Figure 20

Minimum Anchoring Specifications, in. [mm]				
Description		20-40	60	80-100
Number of Bolts		4 or 6*	6	6
A	Bolt Length	6 [152]	6 [152]	8.75 [216]
B	Thread Extension	2-1/2 [64]	2-1/2 [64]	2.75 [64]
C	Bolt Diameter	5/8 [16]	5/8 [16]	3/4 [19]
D	Embedment Depth	3-1/2 [89]	3-1/2 [89]	6 [152]
E	Distance from Bolt Center to Edge of Concrete Pad	Refer to Table 8	Refer to Table 8	Refer to Table 11

* On 20-40 models, the four (4) corner bolts are required and the two (2) center bolts are optional when mounting a machine or elevated base frame to floor.

Table 18

Floor Load Data						
Specification	20	30	40	60	80	100
Static floor load, lbs. [kN]	420 [1.87]	570 [2.54]	700 [3.11]	940 [4.18]	1550 [6.89]	1670 [7.51]
Static pressure, lbs.-ft ² [kN-m ²]	96 [4.60]	99 [4.74]	100 [4.79]	106 [5.08]	137 [6.56]	147 [7.04]

Table 19 2. Floor Load Data continues...

Floor Load Data							
Specification		20	30	40	60	80	100
Dynamic floor load, lbs. [kN]		420 [1.86]	630 [2.80]	840 [3.74]	1260 [5.61]	1680 [7.48]	1680 [7.48]
Dynamic floor pressure, lbs.-ft ² [kN-m ²]		96 [4.60]	109 [5.22]	119 [5.70]	143 [6.85]	149 [7.13]	149 [7.13]
Dynamic load frequency, Hz	F-speed	9.7	9.0	8.6	8.1	7.4	7.4
	V-speed	13.7	12.8	12.2	11.4	10.4	9.5
Maximum moment about machine base, lbs.-ft. [kN-m]		805 [1.09]	1260 [1.71]	1820 [2.47]	2770 [3.76]	4330 [5.87]	4330 [5.87]
Maximum vertical load, lbs. [kN]		795 [3.54]	1150 [5.12]	1470 [6.54]	2080 [9.25]	3050 [13.57]	3140 [13.82]

Table 19 2. Floor Load Data

Drain Connection

IMPORTANT: Machine must be installed in accordance with all local codes and ordinances.

All drain systems must be vented to prevent an air lock or siphoning.

Use the supplied black rubber adapter and clamps to transition from the machine drain outlet to the 2 inches [51 mm] schedule

40 PVC plumbing (20 and 30 models) and the 3 inches [76 mm] schedule 40 PVC plumbing (40-100 models).

If proper drain size is not available or practical, a surge tank is required. A surge tank along with a sump pump should be used when gravity drainage is not possible.

Drain Trough System

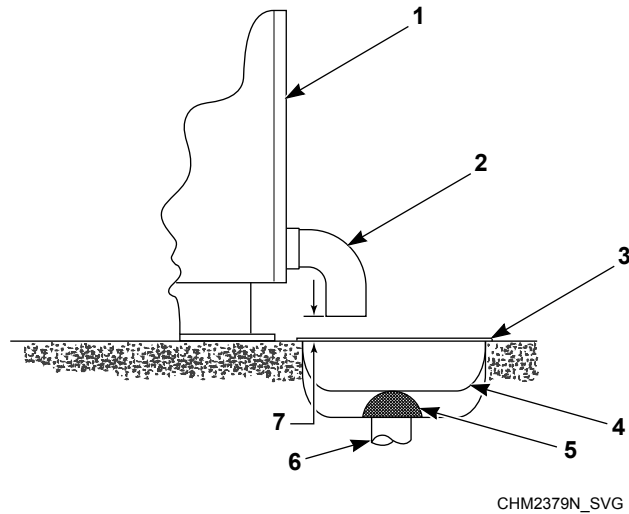

- 1. Rear of Machine
- 2. Drain Pipe
- 3. Steel Grate
- 4. Drain Trough
- 5. Strainer
- 6. Waste Line
- 7. 1 in. [25 mm] minimum gap

Figure 21

Direct Drain System

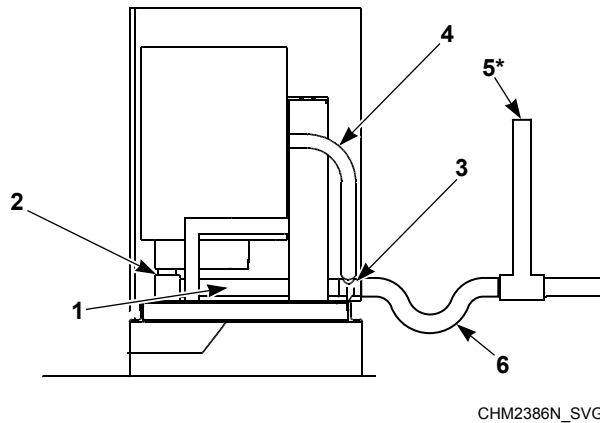

* Drain line must be vented to meet local plumbing codes.

- 1. Drain Hose
- 2. Drain Valve
- 3. Drain Tee
- 4. Overflow Hose
- 5. Vent Pipe*
- 6. Trap (as required by local codes)

Figure 22

IMPORTANT: Increasing the drain hose length, installing elbows, or causing bends will decrease drain flow rates and increase drain times, impairing machine performance.

Drain Information						
Specification	20	30	40	60	80	100
Drain connection size, in. [mm]	2 [51]	2 [51]	3 [76]*	3 [76]*	3 [76]*	3 [76]*
Overflow drain connection size, in. [mm]	1.5 [457]	1.5 [457]	1.5 [457]	1.5 [457]	2.25 [686]	2.25 [686]
Number of drain outlets	1	1	1	1	1	1
Drain flow capacity, gal/min [l/min]	25 [95]	30 [114]	40 [151]	50 [189]	55 [208]	55 [208]
Maximum discharge (level 30), gal [l]	8.24 [31.2]	9.72 [36.8]	10.30 [39]	17.98 [68.1]	26.98 [102.1]	32.16 [121.7]
Recommended drain pit size, ft ³ [l]	2.0 [57]	2.5 [71]	3.5 [128]	5.7 [161]	8.0 [221]	9.5 [269]
*Also works with 3 in. [76 mm] OD PVC pipe if connected to inside of drain tee connector.						

Table 20

Water Connection Requirements

	WARNING
<p>To prevent personal injury, avoid contact with inlet water temperatures higher than 125° Fahrenheit [51° Celsius] and hot surfaces.</p>	
W748	

The maximum water inlet temperature for vended models is 125°F [51°C] and the recommended maximum water inlet temperature for on-premises models is 150°F [66°C] (standard models) or 140°F [60°C] (WRAS approved models).

Connections should be supplied by a hot and a cold water line of at least the sizes shown in *Water Supply Line Sizing*. Installation of additional machines will require proportionately larger water lines.

Connections should be supplied by a hot and a cold water line per national and local codes and in accordance with AS/NZS 3500.1.

To connect water service to a machine with hoses, use the following procedure:

1. Before installing hoses, flush the building’s water system at the machine connection valves for at least two (2) minutes.
2. Check filters in the machine’s inlet hoses for proper fit and cleanliness before connecting.

3. Hang hoses in a large loop; do not allow them to kink.

If additional hose lengths are needed or using hoses other than those supplied by manufacturer, flexible hoses with screen filters are required.

IMPORTANT: Use only new hoses supplied with the machine. Do not reuse old hoses.

Cabinet Hardmount Water Supply Information		
Specification	Model	Requirement
Water inlet connection size, in. BSP [mm]	20-100	3/4 [19]
Thread pitch, GHT [BSPP]	20-100	3/4 x 11.5 [3/4 x 14]
Number of water inlets	20-100	2

Table 21 continues...

Cabinet Hardmount Water Supply Information		
Specification	Model	Requirement
Number of auxiliary water inlets	80-100 (standard models)	2
	80-100 (WRAS- approved models)	0
Recommended pressure, psi [kPa]	20-100	30-85 [200-570]
Inlet flow capacity per inlet, gal/min at 85 psi [l/min at 550 kPa]	20-100	5.2 [20]
	80-100 (auxillary water inlets)	4.0 [15]

Table 21

Water Supply Line Sizing, in. [mm]		
Number of Machines	Supply Line Size	
	Main	Hot/Cold
1	.75 [19]	.75 [19]
2	1 [25]	.75 [19]
3	1.25 [32]	1 [25]
4	1.5 [38]	1 [25]

Table 22

Suitable air cushions (risers) should be installed in supply lines to prevent “hammering.” Refer to *Figure 23*.

Alliance Laundry Systems, LLC ranges of front loading commercial clothes washing machines have solenoid valves at the inlets. The water supply to the washing machines is supplied with an AB air gap between the soap tray and the drum. Minimum and maximum working pressure 30 psi and 85 psi [200 kPa and 570 kPa]. The machines are supplied with approved inlet hoses with a maximum inlet dimension of 1/2 inch [15 mm] (ID).

NOTE: This machine has a fluid category 5 backflow prevention device built in between the soap tray and drum.

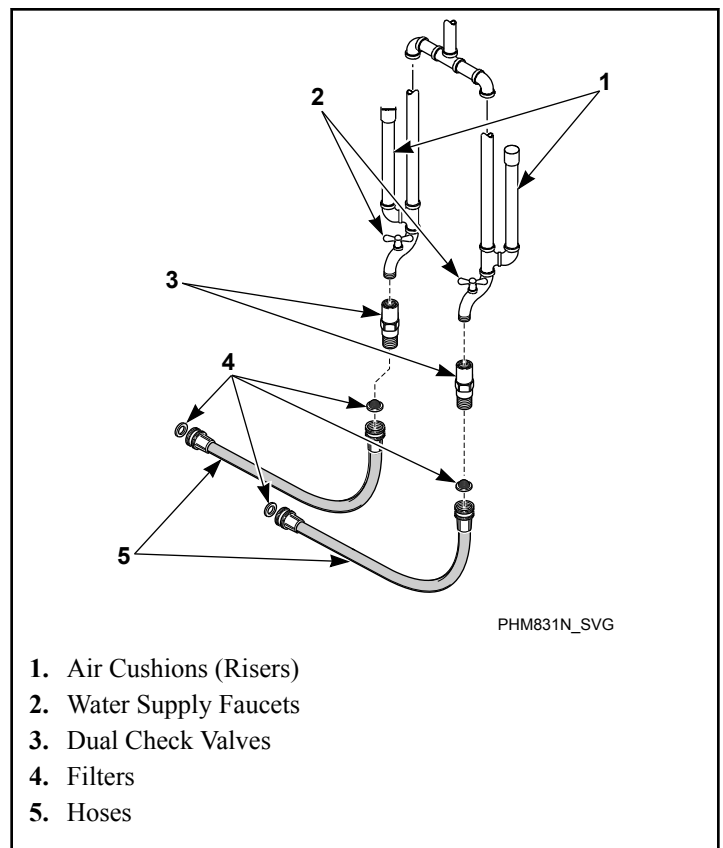

Figure 23

To comply with WRAS (IRN R150) and Australian water regulations, European standard EN1717 and Australian standard AT5200.101, an approved double check valve backflow prevention device with the watermark is provided with the unit and must be fitted at the point of connection(s) between the supply and the fitting. Refer to *Figure 23*.

NOTE: No more than two (2) water connection hoses should be used on WRAS-approved models.



Figure 24



Figure 25

Electrical Installation Requirements

IMPORTANT: Electrical ratings are subject to change. Refer to serial plate for electrical ratings information specific to your machine.

	DANGER
<p>Electrical shock hazard will result in death or serious injury. Disconnect electric power and wait five (5) minutes before servicing.</p>	
W810	

	WARNING
<p>Dangerous voltages are present inside the machine. Only qualified personnel should attempt adjustments and troubleshooting. Disconnect power from the machine before removing any cover and guards, and before attempting any service procedures.</p>	
W736	

	WARNING
<p>Hazardous Voltage. Can cause shock, burn or death. Verify that a ground wire from a proven earth ground is connected to the lug near the input power block on this machine.</p>	
W360	

NOTE: For voltages above or below listed specification, a qualified electrical contractor must be consulted to install the appropriate transformer to meet the OEM electrical specifications. Refer to *North American Approval* and *CE Approval*.

Electrical connections are made at the rear of the machine. The machine must be connected to the proper electrical supply shown on the serial plate on the rear of the machine, using copper conductors only.

IMPORTANT: Alliance Laundry Systems warranty does not cover components that fail as a result of improper input voltage.

Make sure the correct transformer jumper (208 Volt or 240 Volt) is in place. Refer to the “optional” Electrical Service Conversion label located on the back of the machine near the serial plate. Refer to *Figure 26*.

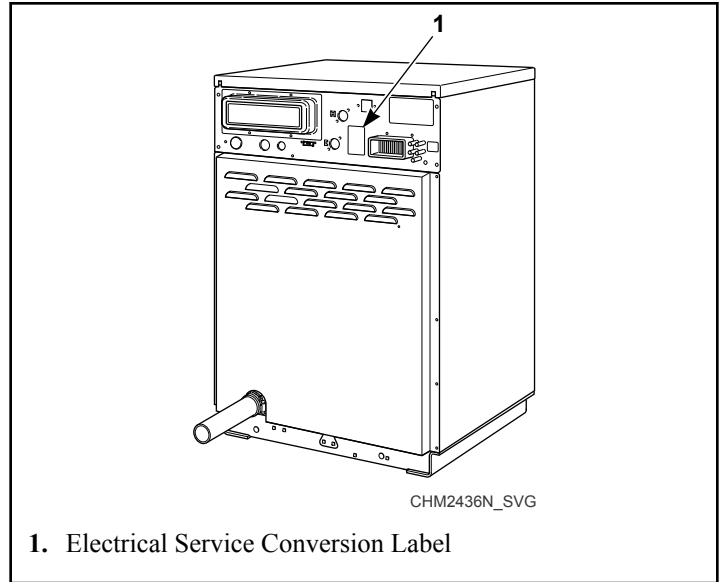

Figure 26

Machines are equipped with an AC inverter drives requiring a clean power supply, free from voltage spikes and surges. Use voltage monitor to check incoming power.

Input Power Conditioning

The drive is suitable for direct connection to input power within the rated voltage of the drive. Listed in *Input Power Condition* are certain input power conditions which may cause component damage or reduction in product life. If any of the conditions exist,

install one of the devices listed under the Possible Corrective Action(s).

IMPORTANT: Only one device per branch circuit is required. It should be mounted closest to the branch and sized to handle the total current of the branch circuit.

Input Power Condition	Possible Corrective Action(s)
Low Line impedance (less than 1% line reactance)	<ul style="list-style-type: none"> • Install Line Reactor • Isolation Transformer
Greater than 120 kVA supply transformer	
Line has power factor correction capacitors	<ul style="list-style-type: none"> • Install Line Reactor • Isolation Transformer
Line has frequent power interruptions	
Line has intermittent noise spikes in excess of 6000V (lightning)	
Phase to ground voltage exceeds 125% of normal line to line voltage	<ul style="list-style-type: none"> • Remove MOV jumper to ground • Install Isolation Transformer with grounded secondary (if necessary)
Ungrounded distribution system	
240V open delta configuration (stinger leg)*	<ul style="list-style-type: none"> • Install Line Reactor
<p>* For drives applied on an open delta with a middle phase grounded neutral system, the phase opposite the phase that is tapped in the middle to the neutral or earth is referred to as the “stinger leg,” “high leg,” “red leg,” etc. This leg should be identified throughout the system with red or orange tape on the wire at each connection point. The stinger leg should be connected to the center Phase B on the reactor.</p>	

Table 23

Input Voltage Requirements

For voltages above or below listed specifications, contact your power company or local electrician.

If machine is intended for four-wire service, a neutral leg must be provided by power company.

If a delta supply system is used on a four-wire model, connect high leg to L3.

IMPORTANT: Improper connections will result in equipment damage and will void warranty.

	DANGER
<p>Electrical shock hazard will result in death or serious injury. Disconnect electric power and wait five (5) minutes before servicing.</p>	
W810	

	DANGER
<p>Hazardous Rotation Speed. Will cause serious injury when controlling AC inverter drive with a parameter unit, safety features are bypassed allowing basket to rotate at high speeds with the door open. Place large sign on front of machine to warn people of imminent danger.</p>	
W361	

Circuit Breakers and Quick Disconnects

Single-phase machines require a single-phase inverse-time circuit breaker. Three-phase machines and V-speed machines require a separate, three-phase inverse-time circuit breaker to prevent damage to the motor by disconnecting all legs if one should be lost accidentally. Refer to *North American Approval* section for model-specific circuit breaker requirements.

IMPORTANT: All quick disconnects should comply with the specifications. DO NOT use fuses instead of circuit breakers.

Connection Specifications

IMPORTANT: Connection must be made by a qualified electrician using wiring diagram provided with machine, or according to accepted European Union standards.

Connect machine to an individual branch circuit not shared with lighting or other equipment. Shield connection in a liquid-tight or approved flexible conduit. Copper conductors of correct size must be installed in accordance with National Electric Code (NEC) or other applicable codes.

Use wire sizes indicated in the Electrical Specifications chart for runs up to 50 feet [15 m]. Use next larger size for runs of 50 to 100 feet [15 to 30 m]. Use two (2) sizes larger for runs greater than 100 feet [30 m].

IMPORTANT: For X voltage - To obtain 200-240V from a 200-240V source, connect L1 and L2. To obtain 220-240V from a 380-415V source, connect L1 and N. Refer to *Figure 27*.

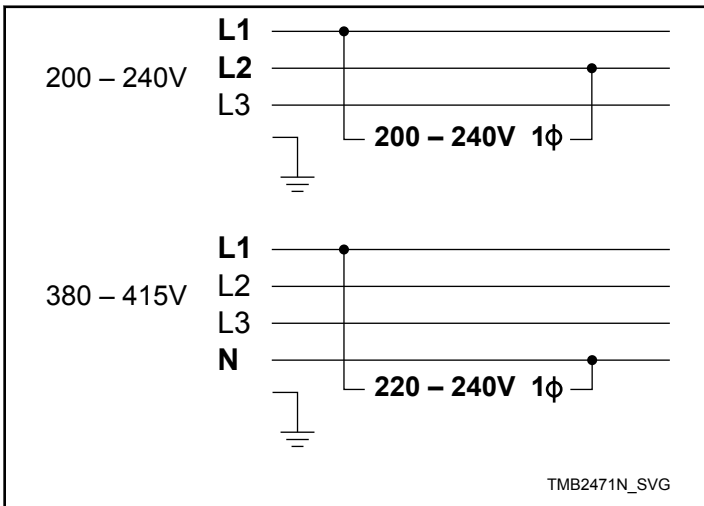

Figure 27

Machine Must Be Hard Wired

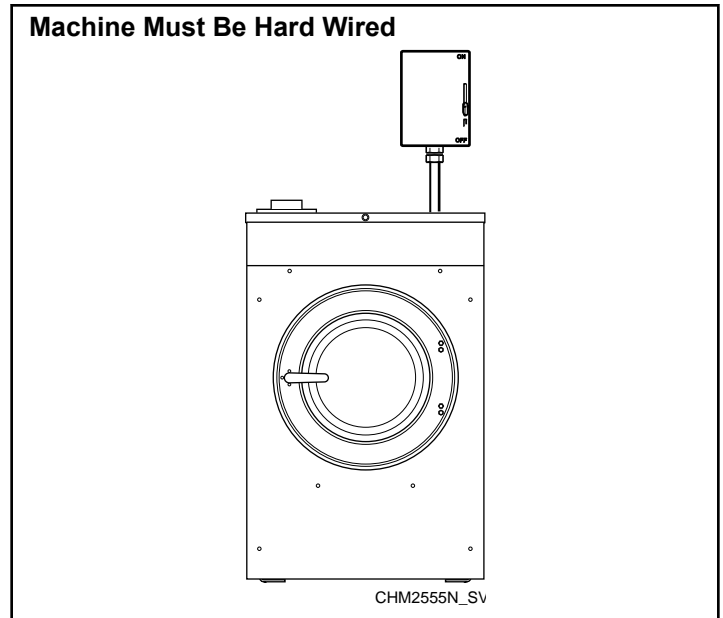

Figure 28

NOTE: Electrical receptacle must be located so that it is easily accessible with machine in place. An intermediate shut-off box with a 3 mm gap is required to meet EN 60335-1, clauses 24.3 and 22.2 or 3.5 mm gap is required to meet Standard IEC 60335-1, clauses 24.3 and 22.2. Gap is defined as the minimum contact separation of each pole in the switch between the “ON” and “OFF” positions.

Single-Phase Connections (120V)

For single-phase input, connect L1, neutral and ground as shown in *Figure 29*.

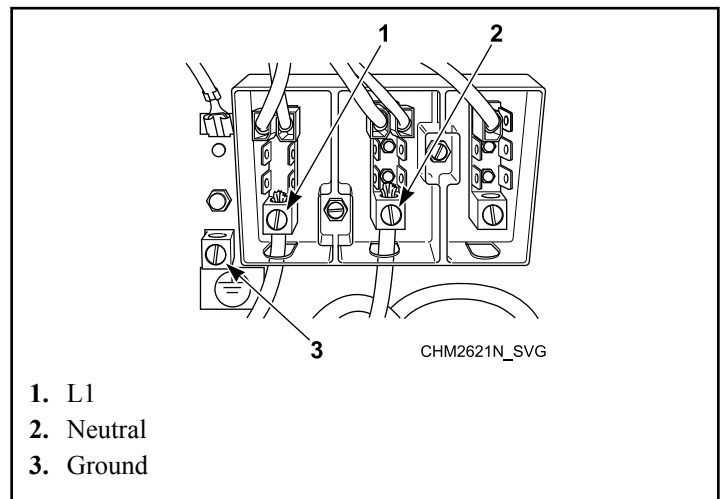

Figure 29

Single-Phase Connections (220V)

For single-phase input, connect L1, L2 and ground and cap neutral as shown in *Figure 30*.

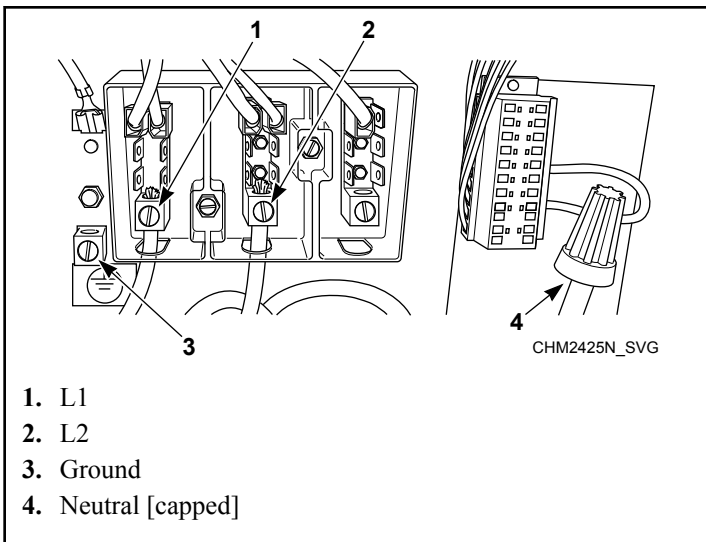

Figure 30

Three-Phase Connections

For three-phase input, connect L1, L2, L3 and Ground as shown in Figure 31.

IMPORTANT: If a stinger leg is used for three-phase input, it **MUST** be connected to L3.

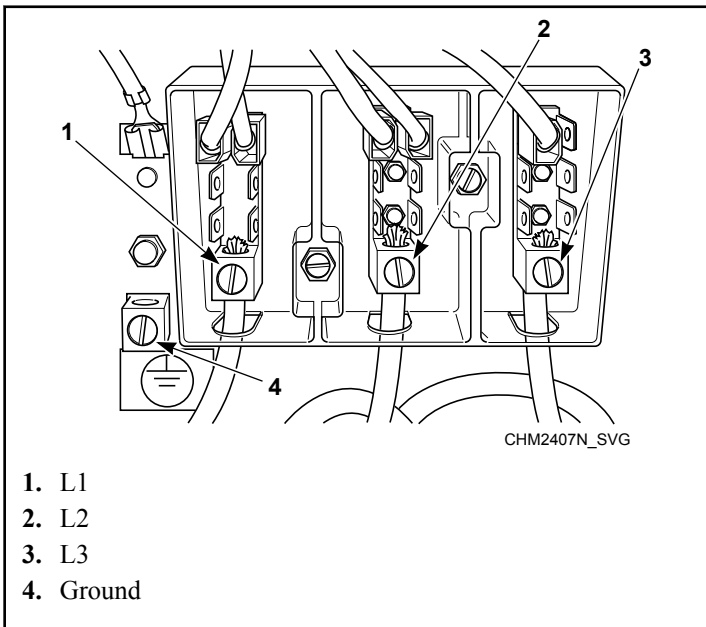

Figure 31

Grounding

For personal safety and proper operation, the machine must be grounded in accordance with state and local codes. If such codes are not available, grounding must conform to the National Electric Code, article 250 (current edition). The ground connection must be made to a proven earth ground, not to conduit or water pipes.

WARNING

Electrically heated machines DO NOT require dual power sources. Do not connect customer power or customer load to the Internal Load Distribution terminal block. Refer to the machine electrical schematic for details.

W759

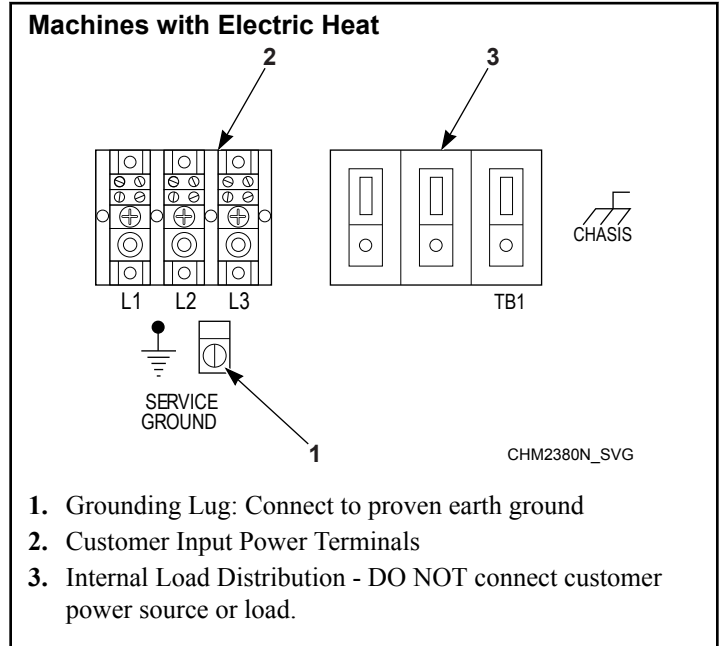

Figure 32

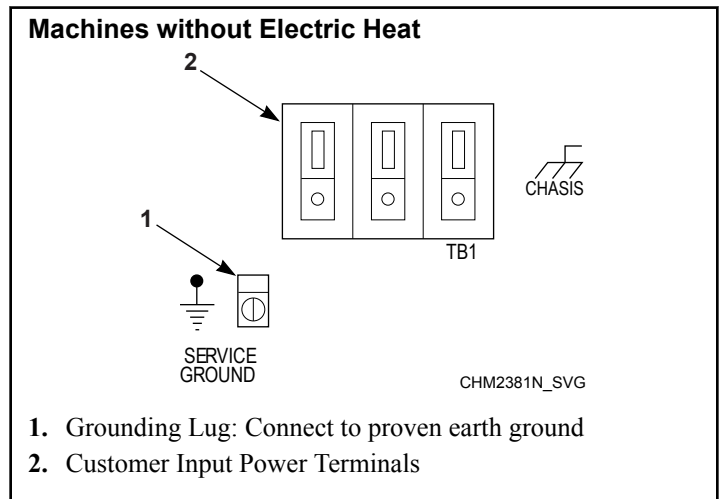

Figure 33

Machines can be converted for lower voltage operation and/or 50 Hz operation. Refer to conversion label by serial plate for details.

Phase Adder

IMPORTANT: Do not use a phase adder on any machine.

Thermal Overload Protector

For V-speed machines, the inverter drive provides overload protection for the drive motor.

North American Approval

20 Models (North American Approval)								
Voltage Designation					Specifications			
Code	Voltage	Cycle	Phase	Wire	Full Load Amps	Circuit Breaker	AWG	mm2
F and V-Speed Models (unless otherwise noted)								
B (F-speed)	120	60	1	2	7	15	14	2.5
B (V-speed)	120	60	1	2	8	15	14	2.5
X	200-208	50/60	1/3	2/3	4/3	15	14	2.5
	220-240							
Q	Standard	50/60	3	3	3	15	14	2.5
	Electric Heat				220-240	21	30	10
N	440-480	50/60	3	3	2	15	14	2.5
P	Standard	50/60	3	3	2	15	14	2.5
	Electric Heat				380-415	13	15	14
NOTE: Wire sizes shown are for copper, THHN, 90°C conductor per NEC article 310.								

Table 24

30 Models (North American Approval)								
Voltage Designation					Specifications			
Code	Voltage	Cycle	Phase	Wire	Full Load Amps	Circuit Breaker	AWG	mm2
F and V-Speed Models (unless otherwise noted)								
B	120	60	1	2	16	20	12	4
X (F-speed)	200-208	50/60	1/3	2/3	5/4	15	14	2.5
	220-240							
X (V-speed)	200-208	50/60	1/3	2/3	6/4	15	14	2.5
	220-240							

Table 25 continues...

30 Models (North American Approval)									
Voltage Designation					Specifications				
Code		Voltage	Cycle	Phase	Wire	Full Load Amps	Circuit Breaker	AWG	mm2
Q	Standard	200–208	50/60	3	3	4	15	14	2.5
	Electric Heat	220-240				22	30	10	6.0
N		440–480	50/60	3	3	3	15	14	2.5
P	Standard	380–415	50/60	3	3	3	15	14	2.5
	Electric Heat					13	15	14	2.5

NOTE: Wire sizes shown are for copper, THHN, 90°C conductor per NEC article 310.

Table 25

40 Models (North American Approval)									
Voltage Designation					Specifications				
Code		Voltage	Cycle	Phase	Wire	Full Load Amps	Circuit Breaker	AWG	mm2
F and V-Speed Models (unless otherwise noted)									
B		120	60	1	2	16	20	12	4
X (F-speed)		200–208	50/60	1/3	2/3	6/4	15	14	2.5
		220-240							
X (V-speed)		200–208	50/60	1/3	2/3	7/4	15	14	2.5
		220-240							
Q	Standard	200-208	50/60	3	3	4	15	14	2.5
	Electric Heat	220-240				42	50	8	10.0
N	Standard	440-480	50/60	3	3	3	15	14	2.5
	Electric Heat					22	30	10	6.0

Table 26 continues...

40 Models (North American Approval)									
Voltage Designation					Specifications				
Code		Voltage	Cycle	Phase	Wire	Full Load Amps	Circuit Breaker	AWG	mm2
P	Standard	380-415	50/60	3	3	3	15	14	2.5
	Electric Heat					25	30	10	6.0

NOTE: Wire sizes shown are for copper, THHN, 90°C conductor per NEC article 310.

Table 26

60 Models (North American Approval)									
Voltage Designation					Specifications				
Code		Voltage	Cycle	Phase	Wire	Full Load Amps	Circuit Breaker	AWG	mm2
F and V-Speed Models (unless otherwise noted)									
X (F-speed)		200-208	50/60	1/3	2/3	9/6	15	14	2.5
		220-240							
X (V-speed)		200-208	50/60	1/3	2/3	10/6	15	14	2.5
		220-240							
Q	Standard	200-208	50/60	3	3	6	15	14	2.5
	Electric Heat	220-240				43	50	8	10.0
N	Standard	440-480	50/60	3	3	4	15	14	2.5
	Electric Heat					22	30	10	6.0
P	Standard	380-415	50/60	3	3	4	15	14	2.5
	Electric Heat					25	30	10	6.0

NOTE: Wire sizes shown are for copper, THHN, 90°C conductor per NEC article 310.

Table 27

80 Models (North American Approval)									
Voltage Designation					Specifications				
Code		Voltage	Cycle	Phase	Wire	Full Load Amps	Circuit Breaker	AWG	mm2
F-Speed Models									
X		200-208	50/60	1/3	2/3	12/8	15	14	2.5
		220-240							
Q	Standard	200-208	50/60	3	3	8	15	14	2.5
	Electric Heat	220-240				72	80	4	25.0
N	Standard	440-480	50/60	3	3	5	15	14	2.5
	Electric Heat					37	40	8	10.0
P	Standard	380-415	50/60	3	3	5	15	14	2.5
	Electric Heat					33	40	8	10.0
V-Speed Models									
X		200-208	50/60	1/3	2/3	15/9	20/15	12/14	4/2.5
		220-240							
Q	Standard	200-208	50/60	3	3	9	15	14	2.5
	Electric Heat	220-240				72	80	4	25.0
N	Standard	440-480	50/60	3	3	6	15	14	2.5
	Electric Heat					37	40	8	10.0
P	Standard	380-415	50/60	3	3	6	15	14	2.5
	Electric Heat					33	40	8	10.0
NOTE: Wire sizes shown are for copper, THHN, 90°C conductor per NEC article 310.									

Table 28

100 Models (North American Approval)									
Voltage Designation					Specifications				
Code		Voltage	Cycle	Phase	Wire	Full Load Amps	Circuit Breaker	AWG	mm2
F-Speed Models									
X		200-208	50/60	1/3	2/3	16/9	20/15	12/14	4/2.5
		220-240							
Q	Standard	200-208	50/60	3	3	9	15	14	2.5
	Electric Heat	220-240				74	80	4	25.0
N	Standard	440-480	50/60	3	3	6	15	14	2.5
	Electric Heat					37	40	8	10.0
P	Standard	380-415	50/60	3	3	6	15	14	2.5
	Electric Heat					34	40	8	10.0
V-Speed Models									
X		200-208	50/60	1/3	2/3	16/10	20/15	12/14	4/2.5
		220-240							
Q	Standard	200-208	50/60	3	3	10	15	14	2.5
	Electric Heat	220-240				74	80	4	25.0
N	Standard	440-480	50/60	3	3	7	15	14	2.5
	Electric Heat					37	40	8	10.0
P	Standard	380-415	50/60	3	3	7	15	14	2.5
	Electric Heat					34	40	8	10.0
NOTE: Wire sizes shown are for copper, THHN, 90°C conductor per NEC article 310.									

Table 29

CE Approval

20 Pound Capacity Models (CE Approval)								
Voltage Designation					Specifications			
Code		Voltage	Cycle	Phase	Wire	Full Load Amps	Circuit Breaker	mm2
F and V-Speed Models								
N		440-480	50/60	3	3	2	6	2.5
X		200-208	50/60	1/3	2/3	4/3	6	2.5
		220-240						
Q	Standard	200-208	50/60	3	3	3	6	2.5
	Electric Heat	220-240				21	25	2.5
P	Standard	380-415	50/60	3	3	2	6	2.5
	Electric Heat					13	16	2.5

NOTE: Wire sizes shown are for copper, THHN, 90°C conductor per NEC article 310.

Table 30

30 Pound Capacity Models (CE Approval)								
Voltage Designation					Specifications			
Code		Voltage	Cycle	Phase	Wire	Full Load Amps	Circuit Breaker	mm2
F and V-Speed Models (unless otherwise noted)								
N		440-480	50/60	3	3	3	6	2.5
X (F-speed)		200-208	50/60	1/3	2/3	5/4	6	2.5
		220-240						
X (V-speed)		200-208	50/60	1/3	2/3	7/4	10/6	2.5
		220-240						
Q	Standard	200-208	50/60	3	3	4	6	2.5
	Electric Heat	220-240				22	25	2.5
P	Standard	380-415	50/60	3	3	3	6	2.5
	Electric Heat					13	16	2.5

Table 31 continues...

30 Pound Capacity Models (CE Approval)							
Voltage Designation					Specifications		
Code	Voltage	Cycle	Phase	Wire	Full Load Amps	Circuit Breaker	mm2
NOTE: Wire sizes shown are for copper, THHN, 90°C conductor per NEC article 310.							

Table 31

40 Pound Capacity Models (CE Approval)								
Voltage Designation					Specifications			
Code	Voltage	Cycle	Phase	Wire	Full Load Amps	Circuit Breaker	mm2	
F and V-Speed Models (unless otherwise noted)								
N	Standard	440-480	50/60	3	3	3	6	2.5
	Electric Heat					22	25	2.5
X	200-208	50/60	1/3	2/3	7/4	10/6	2.5	
	220-240							
Q	Standard	200-208	50/60	3	3	4	6	2.5
	Electric Heat	220-240				42	50	10.0
P (F-Speed)	Standard	380-415	50/60	3	3	3	6	2.5
	Electric Heat					26	32	2.5
P (V-Speed)	Standard	380-415	50/60	3	3	3	6	2.5
	Electric Heat					26	32	2.5
NOTE: Wire sizes shown are for copper, THHN, 90°C conductor per NEC article 310.								

Table 32

60 Pound Capacity Models (CE Approval)								
Voltage Designation						Specifications		
Code		Voltage	Cycle	Phase	Wire	Full Load Amps	Circuit Breaker	mm2
F and V-Speed Models (unless otherwise noted)								
N	Standard	440-480	50/60	3	3	4	6	2.5
	Electric Heat					22	25	2.5
X		200-208	50/60	1/3	2/3	11/7	16/10	2.5
		220-240						
Q	Standard	200-208	50/60	3	3	7	10	2.5
	Electric Heat	220-240				43	50	10.0
P (F-Speed)	Standard	380-415	50/60	3	3	4	6	2.5
	Electric Heat					26	32	2.5
P (V-Speed)	Standard	380-415	50/60	3	3	4	6	2.5
	Electric Heat					26	32	2.5
NOTE: Wire sizes shown are for copper, THHN, 90°C conductor per NEC article 310.								

Table 33

80 Pound Capacity Models (CE Approval)								
Voltage Designation						Specifications		
Code		Voltage	Cycle	Phase	Wire	Full Load Amps	Circuit Breaker	mm2
F-Speed Models								
N	Standard	440-480	50/60	3	3	7	10	2.5
	Electric Heat					37	40	4.0
X		200-208	50/60	1/3	2/3	12/8	16/10	2.5
		220-240						
Q	Standard	200-208	50/60	3	3	8	10	2.5
	Electric Heat	220-240				72	80	16.0

Table 34 continues...

80 Pound Capacity Models (CE Approval)								
Voltage Designation						Specifications		
Code		Voltage	Cycle	Phase	Wire	Full Load Amps	Circuit Breaker	mm2
P	Standard	380-415	50/60	3	3	7	10	2.5
	Electric Heat					33	40	4.0
V-Speed Models								
N	Standard	440-480	50/60	3	3	7	10	2.5
	Electric Heat					37	40	4.0
X		200-208	50/60	1/3	2/3	17/11	20/16	2.5
		220-240						
Q	Standard	200-208	50/60	3	3	11	16	2.5
	Electric Heat	220-240				72	80	16.0
P	Standard	380-415	50/60	3	3	7	10	2.5
	Electric Heat					33	40	4.0
NOTE: Wire sizes shown are for copper, THHN, 90°C conductor per NEC article 310.								

Table 34

100 Pound Capacity Models (CE Approval)								
Voltage Designation						Specifications		
Code		Voltage	Cycle	Phase	Wire	Full Load Amps	Circuit Breaker	mm2
F and V-Speed Models								
N	Standard	440-480	50/60	3	3	7	10	2.5
	Electric Heat					38	40	4.0
X		200-208	50/60	1/3	2/3	17/11	20/16	2.5
		220-240						
Q	Standard	200-208	50/60	3	3	11	16	2.5
	Electric Heat	220-240				74	80	16.0

Table 35 continues...

100 Pound Capacity Models (CE Approval)								
Voltage Designation					Specifications			
Code		Voltage	Cycle	Phase	Wire	Full Load Amps	Circuit Breaker	mm2
P	Standard	380-415	50/60	3	3	7	10	2.5
	Electric Heat					34	40	4.0

NOTE: Wire sizes shown are for copper, THHN, 90°C conductor per NEC article 310.

Table 35

Steam Requirements (Steam Heat Option Only)

	WARNING
<p>Hot Surfaces. Will cause severe burns. Turn steam off and allow steam pipes, connections and components to cool before touching.</p>	
W505	

For machines equipped with optional steam heat, install piping in accordance with approved commercial steam practices. Steam requirements are shown in *Table 36*.

Steam Supply Information		
Steam inlet connection size, in.	40–100*	1/2
Number of steam inlets	1	
Required pressure, (min. - max. psi [kPa])	30–80 [200–550]	
Maximum pressure, psi [kPa]	80 [550]	
*20 and 30 models can be prep for steam and a kit is available for conversion.		

Table 36

IMPORTANT: Failure to install the customer supplied steam filter may void the warranty.

Supply Dispensing

	WARNING
<p>Dangerous Chemicals. May damage eyes and skin. Wear eye and hand protection when handling chemicals; always avoid direct contact with raw chemicals. Read the manufacturer’s directions for accidental contact before handling chemicals. Ensure an eye-rinse facility and an emergency shower are within easy reach. Check at regular intervals for chemical leaks.</p>	
W363	

Supply Dispensing	
Number of liquid chemical supply signals (OPL only)	4
Number of supply compartments	4

Table 37 *continues...*

Supply Dispensing	
Number of external liquid supply connections	5
Liquid supply connection size, in. [mm]	3/8 [8]

Table 37

IMPORTANT: Undiluted chemical dripping can damage the machine. All chemical injection supply dispenser pumps and dispenser tubing should be mounted below the washer’s injection point. Loops do not prevent drips if these instructions are not followed.

IMPORTANT: Failure to follow these instructions could damage the machine and void the warranty.

External Supplies

For proper communication between the machine and an external chemical supply system, it is important for the low-voltage signal power to be connected properly. The included wiring diagram shows several different options for safe and correct wiring of this interface.

The preferred method for connecting the wiring from the external chemical supply system to the machine is to use the 300mA power of the machine’s 24VAC control transformer, which is intended strictly for this purpose. Other voltage and current options are available, but require some wiring changes and must be provided with an external power source. Under no circumstances should the high-voltage machine supply connections or source be used for the communication wiring.

Communication wiring connections, which include a single row of identified terminal blocks, can be found under a service panel at the upper back of the machine.

Chemical Injection Using Internal 24VAC Control Transformer

NOTE: Using the Internal 24VAC 300 Milliamp Control Transformer is recommended by Alliance Laundry Systems.

	CAUTION
<p>Do not attempt to increase fuse rating or alter wiring of external chemical supply terminal strip in such a way that may conflict with the suggested methods provided on the Optional External Supply Wiring Diagram.</p>	
W699	

IMPORTANT: DO NOT remove the red jumper wire from the terminal strip.

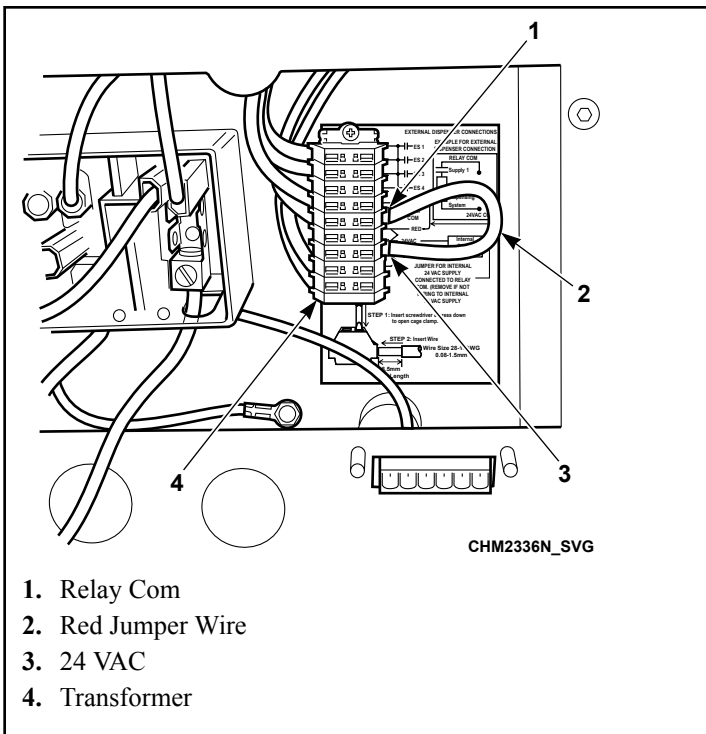

1. Relay Com
2. Red Jumper Wire
3. 24 VAC
4. Transformer

Figure 34

There are 3 terminals necessary for this connection option.

- Terminal “24VAC COM” is used to connect one side of the internal control transformer to the external dispenser input signals common.
- The second terminal is used to connect the other side of the control transformer to the machine output signals common through a red jumper wire between “24VAC” and “RELAY COM”. Refer to *Figure 35*.

IMPORTANT: Do not use the transformer terminals if an external power supply is used.

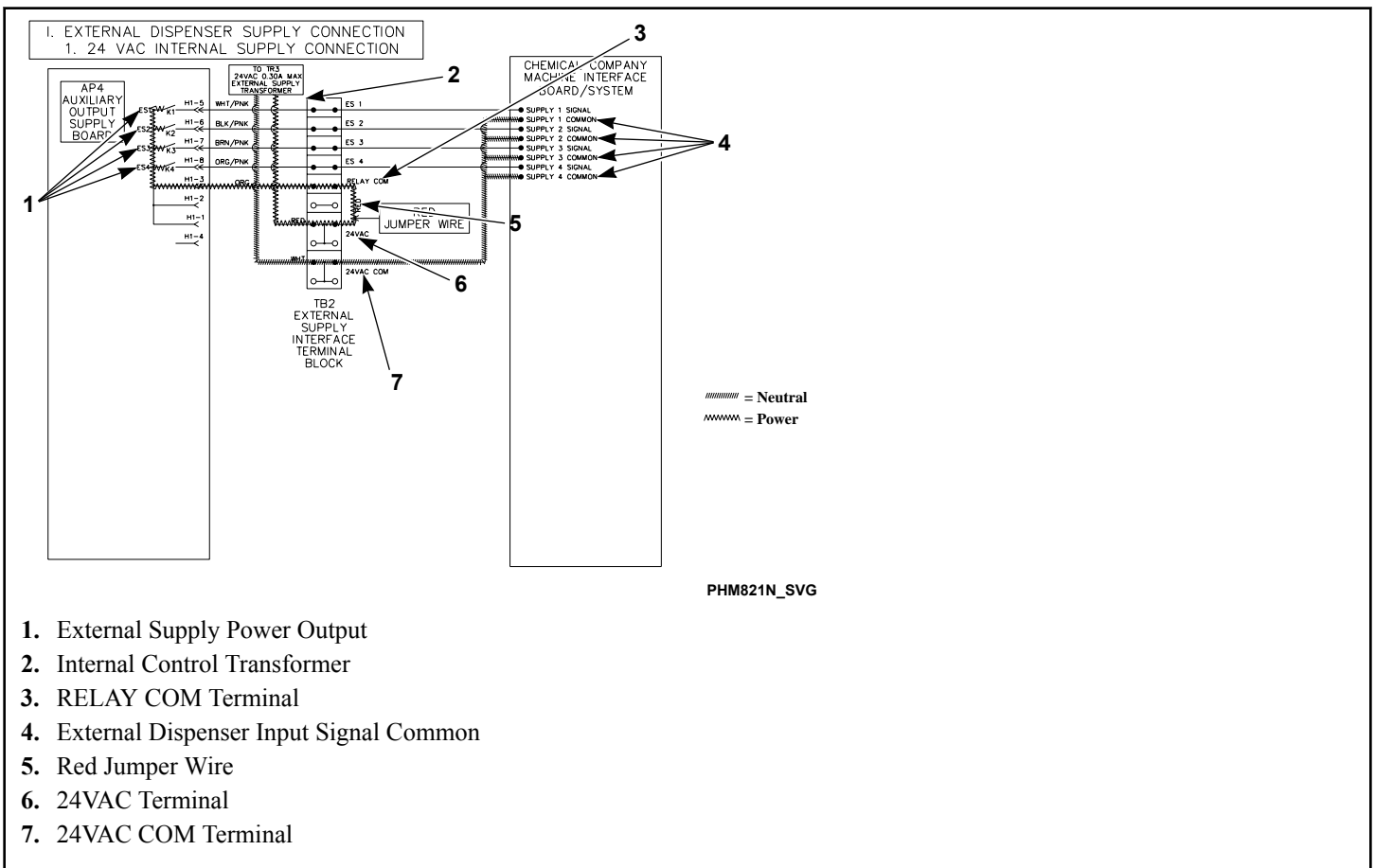

1. External Supply Power Output
2. Internal Control Transformer
3. RELAY COM Terminal
4. External Dispenser Input Signal Common
5. Red Jumper Wire
6. 24VAC Terminal
7. 24VAC COM Terminal

PHM821N_SVG

Figure 35

Chemical Injection Using External AC Power Source

NOTE: An External AC Power Source is NOT provided by Alliance Laundry Systems.

NOTE: Power for external supplies must not be derived from the high-voltage main power connection point.

IMPORTANT: The external power must supply power of 240VAC or less and be protected at 3 Amps or less.

1. Disconnect and cap off the Red and White 24VAC wires.
2. Connect one side of the external power to the “RELAY COM” and the other to the external dispenser input signals common. Refer to *Figure 36*.

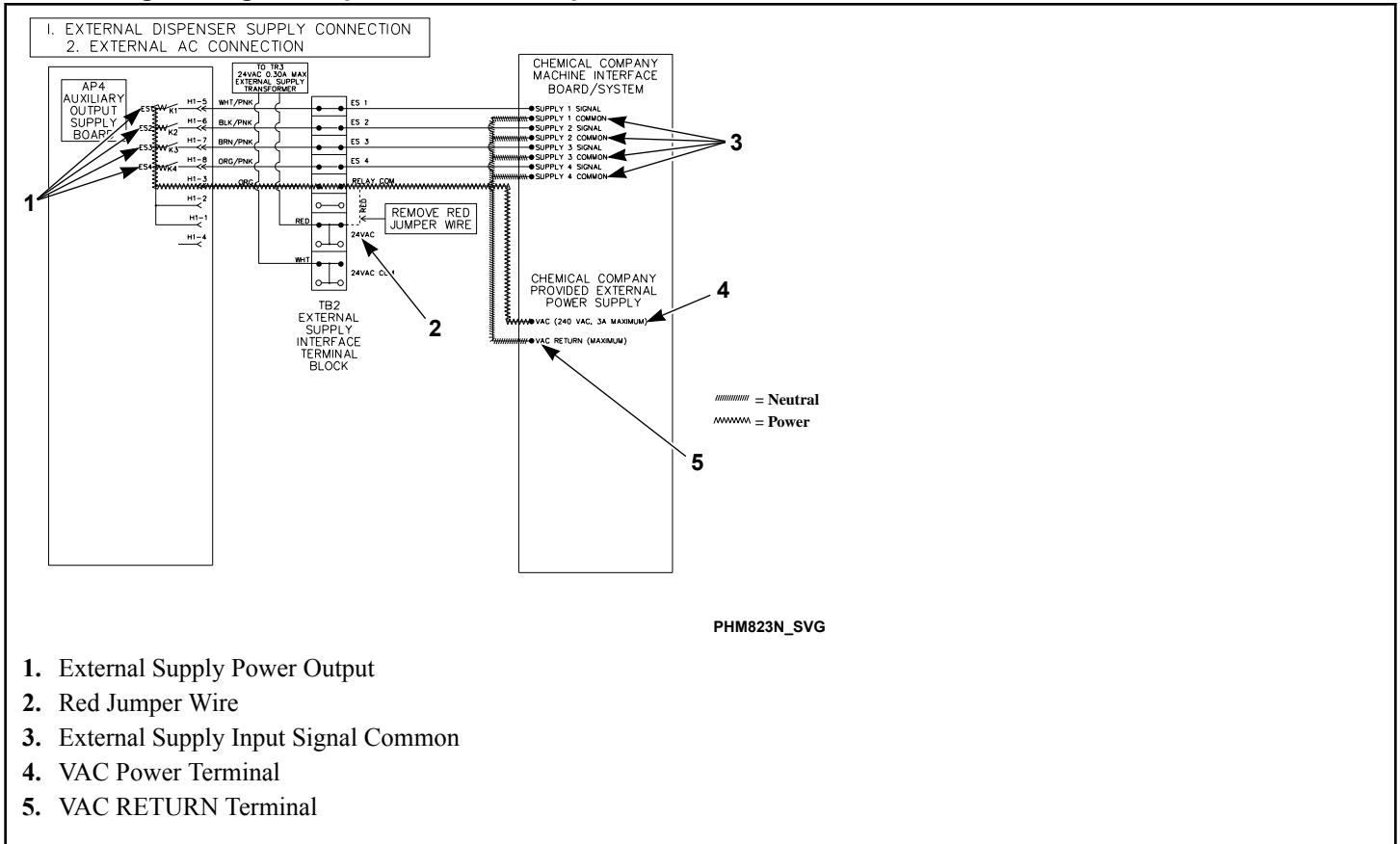

1. External Supply Power Output
2. Red Jumper Wire
3. External Supply Input Signal Common
4. VAC Power Terminal
5. VAC RETURN Terminal

Figure 36

CAUTION

Do not attempt to increase fuse rating or alter wiring of external chemical supply terminal strip in such as way that may conflict with the suggested methods provided on the Optional External Supply Wiring Diagram.

W699

External Supply Signals

Wash-cycle signals are provided to the external chemical supply equipment and a “wait for the next step” signal can be received from the supply equipment.

For example, if ES1 is selected the K1 contact will close and power will be supplied to Supply 1 Signal. The contact will remain closed for the amount of time programmed in control. Refer to *Figure 37* for Internal Supply Connection or *Figure 38* for External AC Connection.

Installation

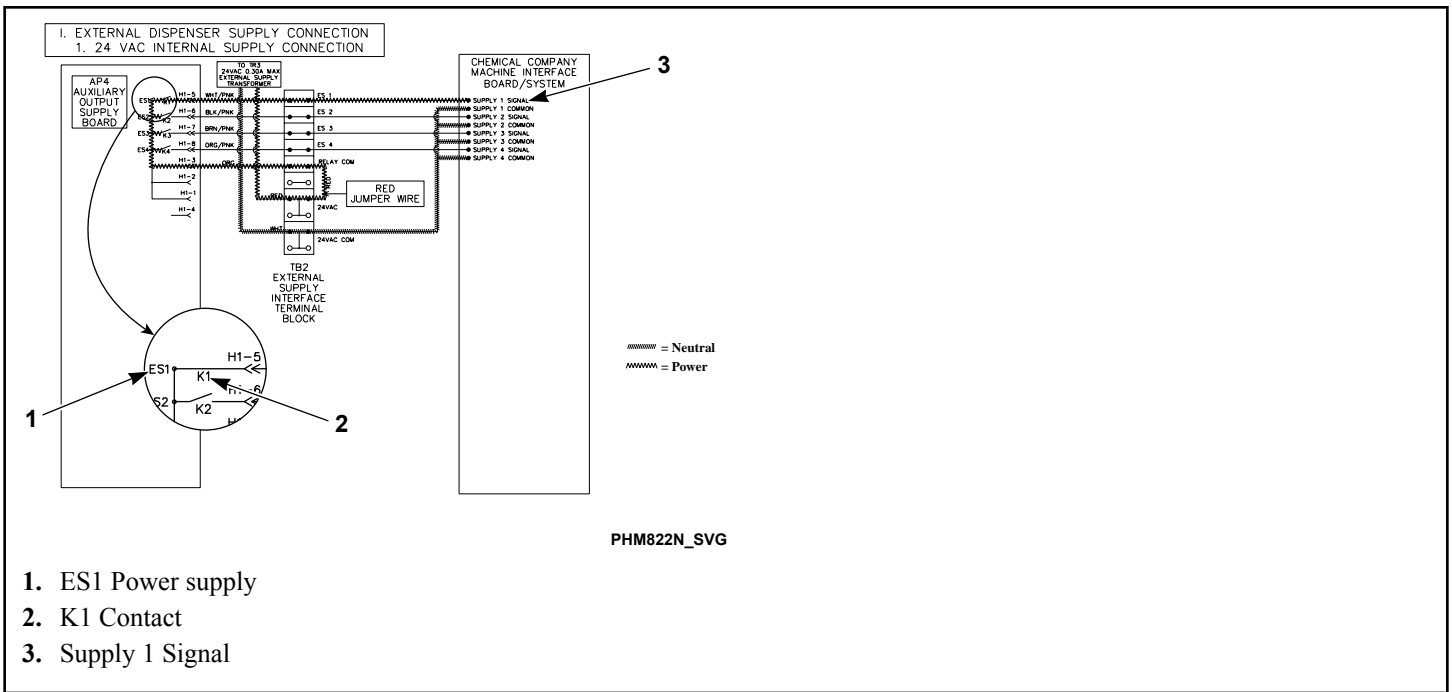

Figure 37

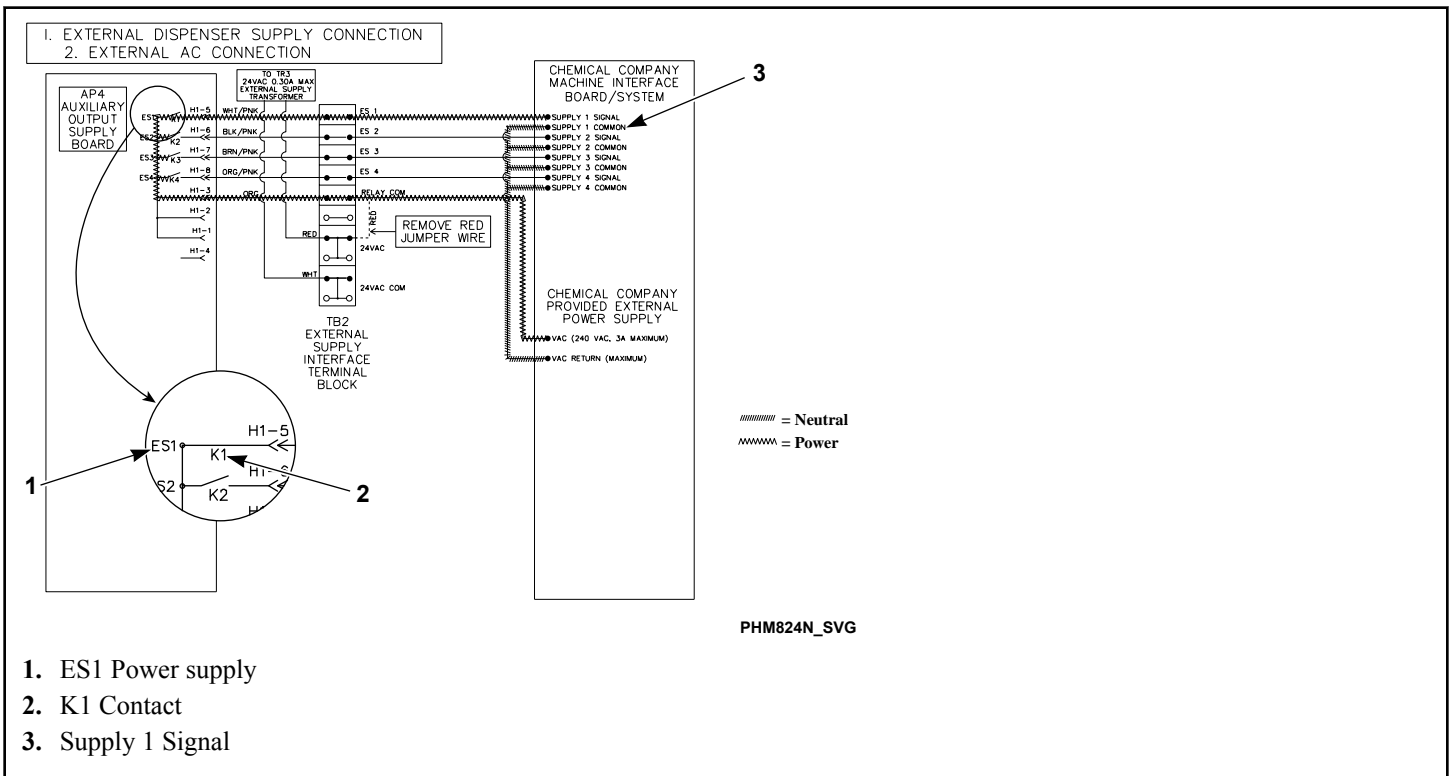

Figure 38

Connection of External Liquid Supplies

OPL Models

1. Facing the rear of the machine, locate the five (5) 3/8 inch [10 mm] supply hose connections found on the right-hand side of the valve panel. Refer to *Figure 39*.

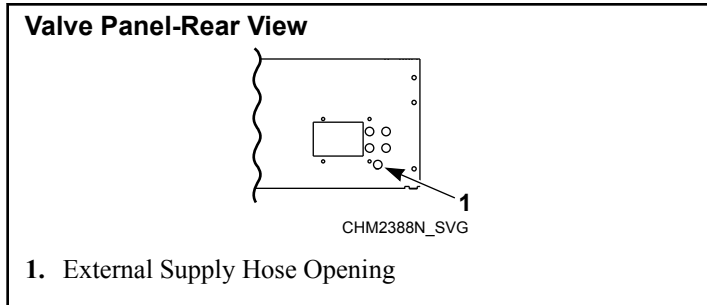

Figure 39

2. Drill through the five (5) plastic holes on the valve panel for the external supply hoses as needed.
3. Remove plastic debris.
4. Attach the external supply hoses to the ports at each of the drilled holes.
5. Secure with proper clamps.

NOTE: Do not attempt to make chemical injection supply pump electrical connections to points other than those provided specifically for that purpose by the factory.

Start Up

Pallet Jack cover Plate Installation (80 and 100 Models Only)

After machine is fully installed, the optional pallet jack cover plate can be installed.

1. Locate the two holes on the front of the machine base frame. Refer to *Figure 40*.

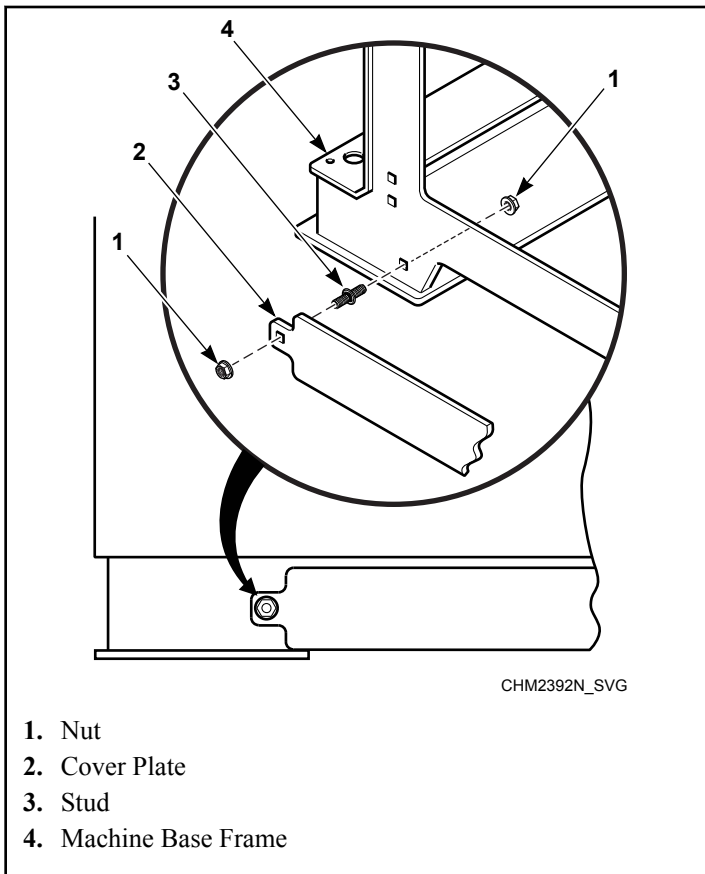

Figure 40

2. Using the hardware from removing plate from back panel, install the cover plate to the machine base frame. The square on stud goes into square hole in machine frame. Refer to *Figure 40*.

Basket Rotation

Check that basket rotation is counterclockwise in the extract step.

1. If rotation is not counterclockwise, disconnect power to machine.
2. Have a qualified electrician reverse any two motor leads at the inverter terminal block.

Operation

Operating Instructions

1. Turn on main power source (circuit breaker).
2. Turn handle clockwise to open. Refer to *Figure 41*.

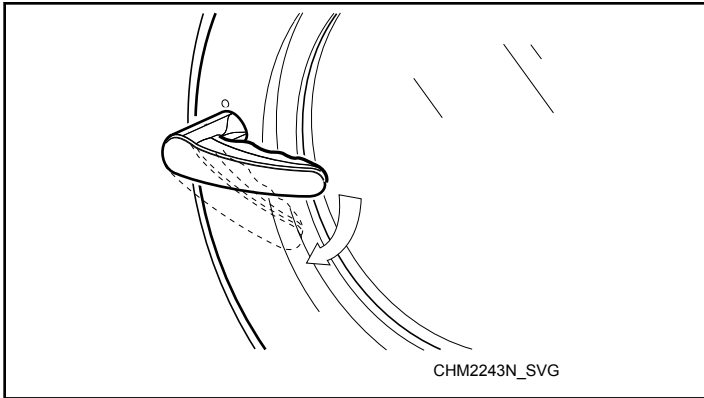

Figure 41

3. Load to capacity whenever possible. DO NOT OVERLOAD. Refer to *Figure 42*.

NOTE: Underloading can cause out-of-balance conditions that can shorten machine life.

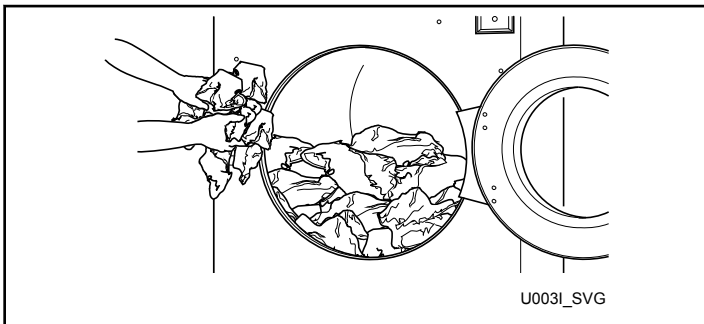

Figure 42

4. Close door and turn handle counter clockwise. Refer to *Figure 43*.

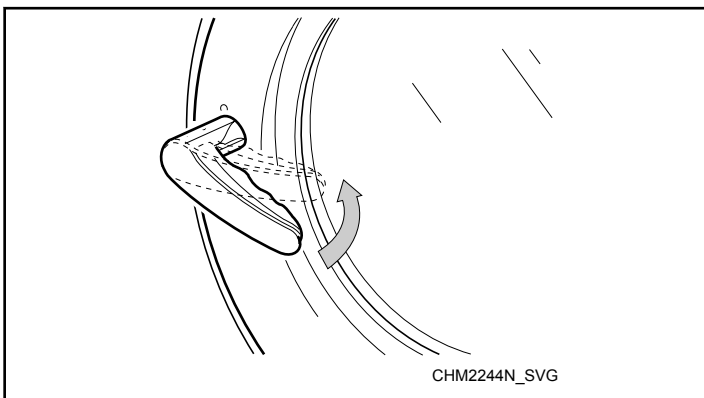

Figure 43

5. The default wash cycle will display.

	WARNING
<p>To prevent personal injury, avoid contact with inlet water temperatures higher than 125° Fahrenheit [51° Celsius] and hot surfaces.</p>	
W748	

6. Select the desired soil setting (select models only), cycle setting (select models only) and cycle/temperature. The LED indicator(s) for that cycle will light.

	CAUTION
<p>Water cannot be extracted from rubber backed items. To avoid damage to machine from out of balance conditions, do not use a spin (extract) step when washing rubber backed items. Warranty will be voided.</p>	
W880	

7. Add liquid and/or powder supplies to supply dispenser. Refer to *Table 38*.

- a. Detergent:
 - Liquid - Compartment 1 (prewash) + Compartment 3
 - Powder - Compartment 1 (prewash) + Compartment 2
- b. Bleach:
 - Liquid - Compartment 3
 - Powder - Compartment 2
- c. Softener:
 - Liquid - Compartment 4

8. For vended models only, insert coin(s) or card as necessary.
 - If the machine is a coin operated unit, add coins. As each coin is added, the vend counts down to the amount remaining.
 - If the machine is a card operated unit, insert and remove card per card system instructions.
 - If the unit is interfaced to a central/remote pay system, go to the central/remote pay console, make payment and select the machine and follow central/remote pay system instructions.
9. Press the START keypad.
10. During first fill, the desired wash cycle can be changed. After first fill has ended, the wash cycle active at that moment remains the chosen wash cycle.
11. When cycle is complete, display shows “00”.



<p>a. DETERGENT</p>	 <p>1. Liquid Detergent</p>	 <p>2. Powder Detergent</p>
<p>b. BLEACH</p>	 <p>3. Liquid Bleach</p>	 <p>4. Powder Bleach</p>
<p>c. SOFTENER</p>	 <p>5. Liquid Softener</p>	

Table 38

Maintenance

Maintenance

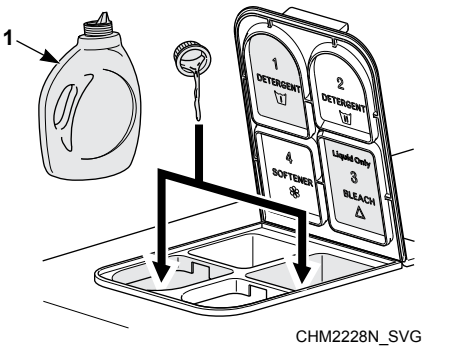
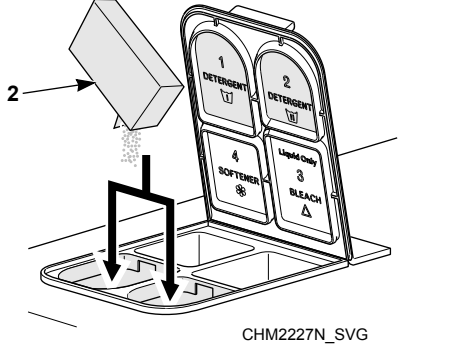
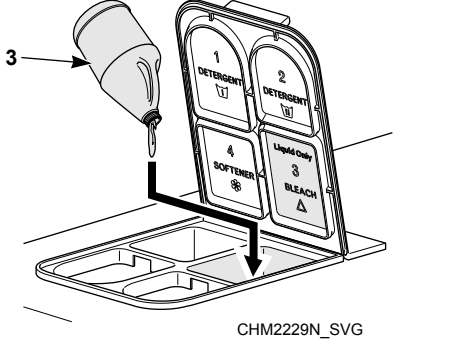
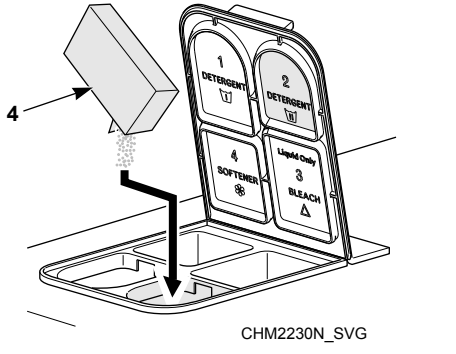
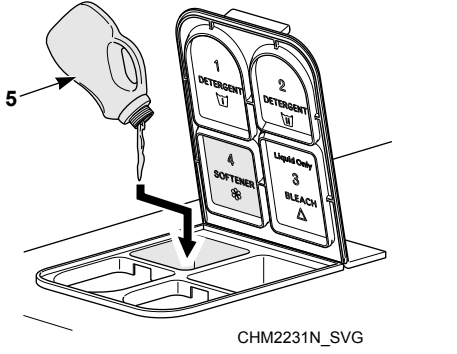
	WARNING
<p>Sharp edges can cause personal injury. Wear safety glasses and gloves, use proper tools and provide lighting when handling sheet metal parts.</p>	
W366R1	

IMPORTANT: Replace all panels that are removed to perform service and maintenance procedures. Do not operate the machine with missing guards or with broken or missing parts. Do not bypass any safety devices.

Daily

IMPORTANT: Replace all panels that are removed to perform maintenance procedures. Do not operate the machine with missing guards or with broken or missing parts. Do not bypass any safety devices.

	WARNING
<p>Do not spray the machine with water. Short circuiting and serious damage may result.</p>	
unique_57_Connect_42_note-1437506691659	

IMPORTANT: Door lock should be checked daily to ensure proper operation. Also check that all safety and instruction stickers are on the machine. Any missing or illegible safety instructions stickers should be replaced immediately.

Beginning of Day

1. Check door interlock before starting operation:
 - a. Attempt to start the machine with the door open. The machine should not start.
 - b. Close the door without locking it and start the machine. The machine should not start.
 - c. Attempt to open the door while the cycle is in progress. The door should not open.
- If the door lock and interlock are not functioning properly, disconnect power and call a service technician.
2. Check the machine for leaks.
 - a. Start an unloaded cycle to fill the machine.
 - b. Verify that door and door gasket do not leak.

- c. Verify that the drain valve is operating and that the drain system is free from obstruction. If water does not leak out during the first wash segment, the drain valve is closed and functioning properly.

3. Inspect water inlet valve hose connections on the back of the machine for leaks.
4. Inspect steam hose connections for leaks (if applicable).
5. On machines equipped with an automatic Chemical Supply System, check all the hoses and hose connections for leaks or visible signs of deterioration. Replace immediately if either are present. Chemical leaks can cause damage to the machine's components.

	WARNING
<p>To reduce the risk of electrical shock, serious injury or death, disconnect the electrical power to washer-extractor before examining the wiring.</p>	
W636	

6. Verify that insulation is intact on all external wires and that all connections are secure. If bare wire is evident, call a service technician.
7. Ensure all panels and guards are properly installed.

End of Day

1. Inspect and clean the basket and door gasket of residual detergent and all foreign matter.
2. Clean the door glass and between the door gasket and the door with a damp cloth.
3. Clean automatic supply dispenser lid and general area with mild detergent. Flush the dispenser with clean water.
4. Clean the machine's top, front and side panels with all-purpose cleaner. Rinse with clean water and dry.

IMPORTANT: Use only isopropyl alcohol to clean graphic overlays. Never use ammonia-based, vinegar-based or acetone-based cleaners on graphic overlays.

NOTE: Unload the machine promptly after each completed cycle to prevent moisture buildup. Leave loading door and dispenser lid open at the end of each completed cycle to allow moisture to evaporate.

5. Shut off water supply.

Monthly

NOTE: Disconnect power to the machine at its source before performing the monthly maintenance procedures.

Maintenance

1. Verify points of contact at terminals and quick disconnects are firm throughout the machine by gently tugging the wires. Re-seat any loose contacts.
2. **For 80 and 100 models only**, each month OR after every 200 hours of operation, lubricate bearings (locate the bearing lubrication decal under the top panel). Visually inspect grease line for air pockets; purge to remove.

The grease must have the following characteristics:

- NLGI Grade 2
- Lithium-based
- Water-insoluble
- Anti-rusting
- Anti-oxidizing
- Mechanically stable

The grease must have adequate base oil viscosity with one of the following ratings:

- ISO VG 150 (709–871 SUS at 100°F [135–165 cSt at 40°C])
- ISO VG 220 (1047–1283 SUS at 100°F [198–242 cSt at 40°C])
- An SAE 40 rating is also acceptable as long as the cSt or SUS values are within the specified ranges.

Pump the grease gun slowly, permitting only 2 strokes.

NOTE: Do not pump the grease gun until grease comes out of the bearing housing. This can result in over lubrication, causing damage to bearings and seals.

3. Clean inlet hose filter screens:
 - a. Turn water off and allow valve and water line to cool, if necessary.
 - b. Unscrew inlet hose from the faucet and remove filter screen.
 - c. Clean with soapy water and reinstall. Replace if worn or damaged.
 - d. Repeat procedure with the filter located inside the valve at the back of the machine.

NOTE: All filter screens should be replaced every five years.

4. Clean customer-supplied steam filter (if applicable). Refer to *Figure 44*.
 - a. Turn off steam supply and allow time for the valve to cool.
 - b. Unscrew cap.
 - c. Remove element and clean.
 - d. Replace element and cap.

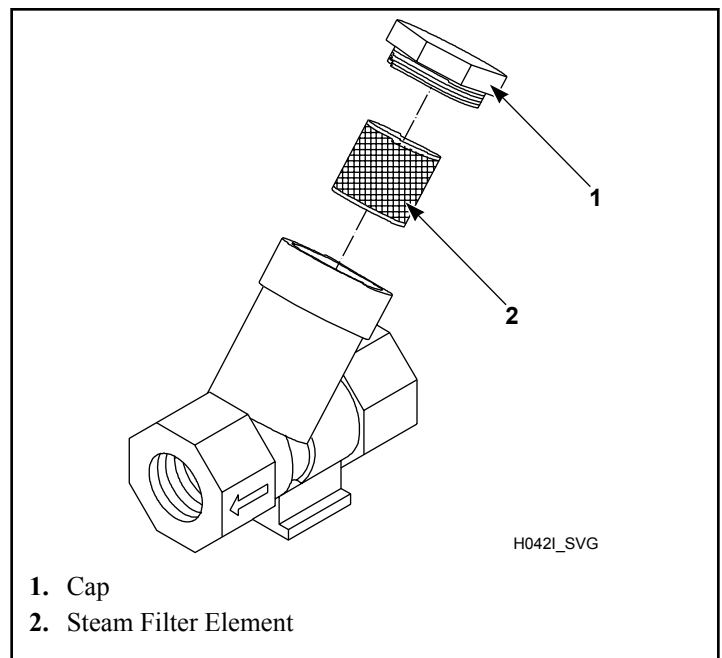

Figure 44

5. Clean interior of machine, by wiping with a water-soaked sponge or cloth.
6. If applicable, check the supply dispenser hoses and hose connections for leaks or visible signs of deterioration. Replace immediately if either are present.

Yearly

NOTE: Disconnect power to the machine at its source before performing maintenance procedures.

1. Remove the front panel(s) and rear access panels and inspect all hose, drain, and overflow connections/clamps for leaks. Inspect all hoses for visible signs of deterioration. Replace as necessary.
2. Inspect and vacuum clean the inverter heat sink (where applicable).
3. Use a vacuum to clean lint from motor.
4. Remove chemical supply components and check all flush hoses and connections for residual chemicals, leaks or visible signs of deterioration. Clean or replace as necessary.

NOTE: Hoses and other natural rubber parts deteriorate after extended use. Hoses may develop cracks, blisters or material wear from the temperature and constant high pressure they are subjected to.

NOTE: All hoses should be replaced every five years.

5. Use compressed air to ensure that all electrical components including coin acceptors (if applicable) are free of moisture and dust.
6. Tighten door hinges and fasteners, if necessary.

7. Tighten motor mounting bolt locknuts and bearing bolt locknuts, if necessary.
8. Check the tightness of the motor spring and motor pulley hardware. Also check that the eyebolt is tightened properly.
9. Verify that the drain motor shield is in place and secure, if so equipped.
10. Check the bearing mounting bolts to make sure they are torqued properly. Refer to *Torque* .

Torque, ft.-lbs.		
Model	Bearing	Torque
20	All	41
30-40	All	101
60	All	201
80-100	All	357

Table 39

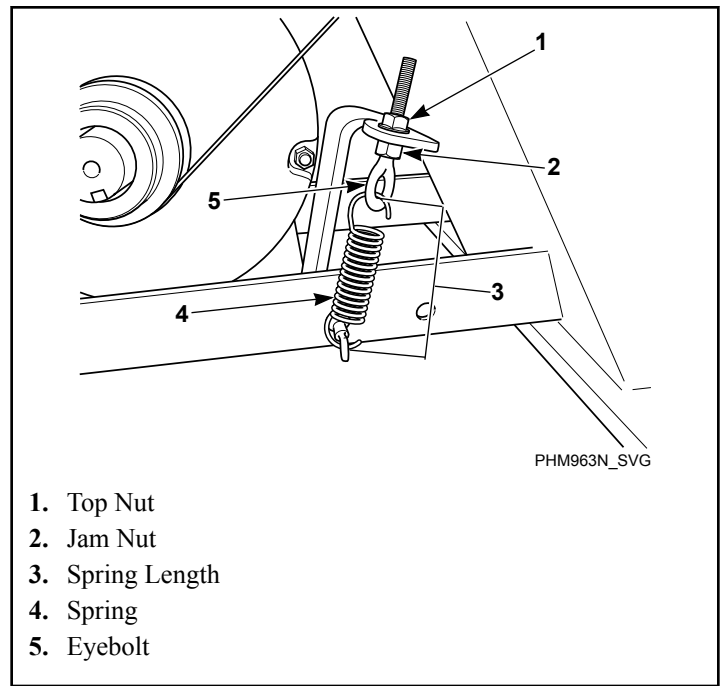

1. Top Nut
2. Jam Nut
3. Spring Length
4. Spring
5. Eyebolt

Figure 45

11. Use the following procedures to determine if belt(s) require replacement or adjustment. Call a qualified service technician in either case.
 - a. Check belt(s) for uneven wear and frayed edges. Belts must not be twisted and must be properly seated on pulleys.
 - b. After disconnecting power to the machine and removing all panels necessary for access to the drive belt, use one of the following methods to verify that the belt is properly tensioned.

NOTE: Basket pulley must be rotated three (3) full turns before assessing belt tension after every adjustment.

- **Frequency Gauge.** Tighten eyebolt top nut until the correct frequency (refer to *Table 42*) is obtained mid-span. Torque jam nut to spring bracket to 20.6 ± 2 ft.-lbs. Refer to *Figure 45* .

- **Tension Gauge.** Tighten eyebolt top nut until the proper belt gauge (refer to *Table 42*) is obtained mid-span. Torque jam nut to spring bracket to 20.6 ± 2 ft.-lbs. Refer to *Figure 45* .
- **Spring Length.** Tighten eyebolt top nut until the spring measures the correct distance between the hooks. Refer to *Table 40* . Torque jam nut to spring bracket to 20.6 ± 2 ft.-lbs. Refer to *Figure 45* .

Spring Length, in. [mm]	
Model	Distance Between Hooks
20 (2 HP)	5 1/8 [130]
30-40	4 3/4 [121]
60	5 1/16 [129]
80-100	4 3/4 [121]

Table 40

- **Burroughs Gauge (20 models with 1 HP only).** Use a Burroughs belt gauge to obtain proper tension. Proper belt tension is obtained when belt can be deflected from normal position (refer to *Figure 46*) when moderate pressure of is applied to the point midway between pulleys.

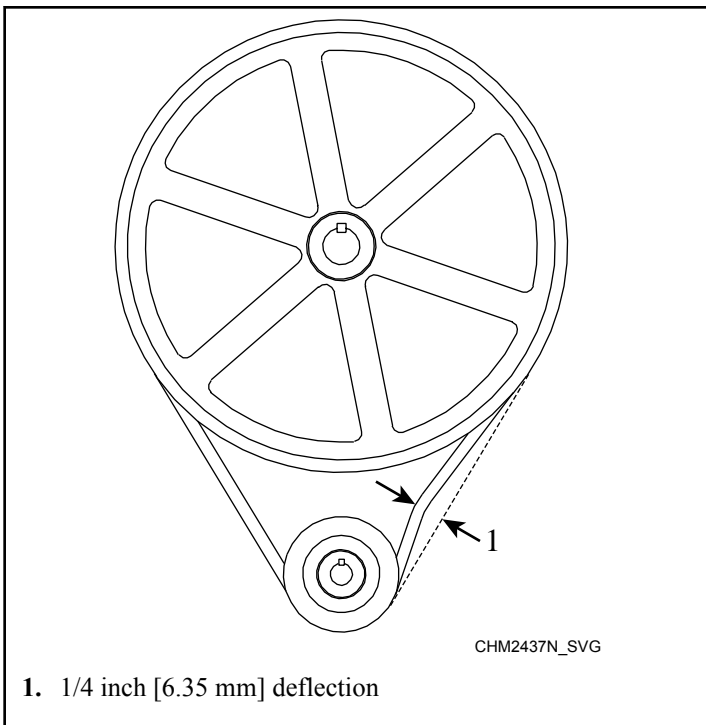

Figure 46

- **Maintain Tension During Belt Removal.** If proper tension is achieved, tape the jam nut in place and loosen eyebolt top nut to release the belt. Replace belt and retighten eyebolt top nut back to jam nut position. Refer to *Figure 45*.

IMPORTANT: All torque joints must remain dry (non-lubricated).

- Verify allowable distance of belt from edge of basket pulley. Refer to *Flat-Pulley Alignment*.

Flat-Pulley Alignment, in. [mm]	
Model	Minimum Allowable Distance from Edge
20	.09 [2]
30	.09 [2]
40	.09 [2]
60	.38 [10]

Table 41

Belt Tension by Frequency or Belt Tension Gauge			
Model	Frequency (Hz)	Belt Tension (lbs.)	Tension Gauge (N)
20 (1 HP)	95 ± 2	39.6 ± 1.5	176 ± 7
20 (2 HP)*	98 ± 2	70.2 ± 5.6	312 ± 25
30*	99 ± 4	71 ± 5.6	317 ± 25
40*	87 ± 84	70.3 ± 6.3	313 ± 28
60*	87 ± 4	92.7 ± 8.8	413 ± 39
80	102 ± 2	132 ± 5	588 ± 23
100	118 ± 2	170.6	756.2

* Models made before 10/13/14 are self-tensioning and do not require any adjustment.

Table 42

- Remove the back panel and check overflow hose and drain hose for leaks or visible signs of deterioration. Replace immediately if either are present.
- Place a large magnet over the normally-closed ball switch to verify the stability switch operation.
- Run a factory test. Reference Programming Manual for procedure details and components tested.
- Check all painted surfaces for exposed metal.
 - If bare metal is showing, paint with primer or solvent-based paint.
 - If rust appears, remove it with sandpaper or by chemical means. Then paint with primer or solvent-based paint.
- Tighten anchor bolts, if necessary.
- Tighten anchor bolts as specified in the *Machine Mounting and Grouting* section, if necessary. Inspect grout for cracking.

IMPORTANT: All torque joints must remain dry (non-lubricated).

Care of Stainless Steel

- Remove dirt and grease with detergent and water. Thoroughly rinse and dry after washing.
- Avoid contact with dissimilar metals to prevent galvanic corrosion when salty or acidic solutions are present.
- Do not allow salty or acidic solutions to evaporate and dry on stainless steel. Wipe clean of any residues.
- Rub in the direction of the polish lines or “grain” of the stainless steel to avoid scratch marks when using abrasive cleaners. Use stainless steel wool or soft, non-metal bristle brushes. Do not use ordinary steel wool or steel brushes.
- If the stainless steel appears to be rusting, the source of the rust may be an iron or steel part not made of stainless steel, such as a nail or screw.
- Remove discoloration or heat tint from overheating by scouring with a powder or by employing special chemical solutions.
- Do not leave sterilizing solutions on stainless steel equipment for prolonged periods of time.
- When an external chemical supply is used, ensure no siphoning of chemicals occurs when the machine is not in use. Highly concentrated chemicals can cause severe damage to stainless steel and other components within the machine. Damage of this kind is not covered by the manufacturer’s warranty. Locate the pump and tubing below the machine’s injection point to prevent siphoning of chemicals into the machine.

Disposal of Unit

This appliance is marked according to the European directive 2002/96/EC on Waste Electrical and Electronic Equipment (WEEE).

This symbol on the product or on its packaging indicates that this product shall not be treated as household waste. Refer to *Figure 47*. Instead it shall be handed over to the applicable collection point for the recycling of electrical and electronic equipment. Ensuring this product is disposed of correctly will help prevent potential negative consequences for the environment and human health which could otherwise be caused by inappropriate waste handling of this product. The recycling of materials will help to conserve natural resources. For more detailed information about recycling of this product, please contact the local city office, household waste disposal service, or the source from which the product was purchased.

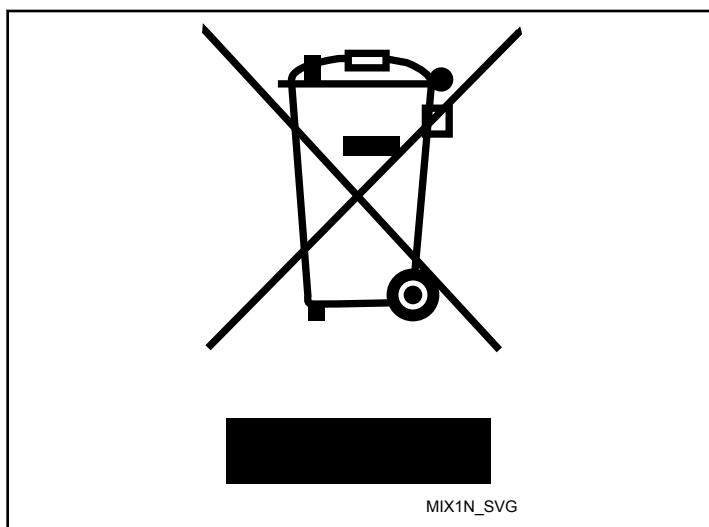



Figure 47

China Restriction of hazardous substances (RoHS)

The Table of Hazardous Substances/Elements and their Content

As required by China's Management Methods for Restricted Use of Hazardous Substances in Electrical and Electronic Products

Hazardous substances						
Part Name	Lead (Pb)	Mercury (Hg)	Cadmium (Cd)	Hexavalent Chromium (CR[VI])	Polybrominated biphenyls (PBB)	Polybrominated diphenyl ethers (PBDE)
PCBs	X	O	O	O	O	O
Electromechanical Parts	O	O	O	O	O	O
Cables and Wires	O	O	O	O	O	O
Metal Parts	O	O	O	O	O	O
Plastic Parts	O	O	O	O	O	O
Batteries	O	O	O	O	O	O
Hoses and Tubing	O	O	O	O	O	O
Timing Belts	O	O	O	O	O	O
Insulation	O	O	O	O	O	O
Glass	O	O	O	O	O	O
Display	O	O	O	O	O	O
<p>This table is prepared in accordance with the provisions of SJ/T-11364.</p> <p>O: Indicates that the content of said hazardous substance in all of the homogenous materials in the component is within the limits required by GB/T 26572.</p> <p>X: Indicates that the content of said hazardous substance exceeds the limits required by GB/T 26572 in at least one homogenous material in the component.</p> <p>All parts named in this table with an "X" are in compliance with the European Union's RoHS Legislation.</p> <p>NOTE: The referenced Environmental Protection Use Period Marking was determined according to normal operating use conditions of the product such as temperature and humidity.</p>						
	This product under normal use, durable years of environmental protection is 15 years.					