

MOE/S series

1,000kg

Medium and High Level Order Picker



- Yale AC technology
- AC motors
- CAN bus
- Fly-by-wire steering
- Enhanced comfort and performance
- Low maintenance features

VDI 2198 General Specifications - MO10E

			Yale	Yale	Yale	Yale	
Distinguishing mark	1.1	Manufacturer (abbreviation)					
	1.2	Manufacturer's type designation	MO10E 7 FC	MO10E 14 FC	MO10E 12	MO10E 12 SL	
	1.3	Drive: electric (battery or mains), diesel, petrol, fuel gas	Electric (battery)	Electric (battery)	Electric (battery)	Electric (battery)	
	1.4	Operator type: hand, pedestrian, standing, seated, order-picker	Order-picker	Order-picker	Order-picker	Order-picker	
	1.5	Rated capacity/Rated load	Q (t)	1.0	1.0	1.0	
	1.6	Load centre distance	c (mm)	600	600	600	
	1.8	Load distance, centre of drive axle to fork ⁽¹⁾	x (mm)	144	144	96	
	1.9	Wheelbase	y (mm)	1390	1390	1390	
	2.1	Service weight ⁽⁹⁾ ⁽¹⁰⁾	kg	1550	1750	1600	
Weights	2.2	Axle loading, laden front/rear	kg	350 / 2200	350 / 2400	350 / 2250	
	2.3	Axle loading, unladen front/rear	kg	900 / 650	950 / 800	900 / 700	
	3.1	Tyres: polyurethane, tophane, vulkollan, front/rear		Vulkollan / Vulkollan	Vulkollan / Vulkollan	Vulkollan / Vulkollan	
Tyres/chassis	3.2	Tyre size, front	ř (mm x mm)	254 x 125	254 x 125	254 x 125	
	3.3	Tyre size, rear	ř (mm x mm)	125 x 94	125 x 94	125 x 94	
	3.5	Wheels, number front/rear (x = driven wheels)		1x / 2	1x / 2	1x / 2	
	3.7	Tread, rear	b ₁₁ (mm)	660	660	660	
	Dimensions	4.2	Height, mast lowered	h ₁ (mm)	1074	1794	1654
		4.4	Lift	h ₃ (mm)	690	1410	1010
4.5		Height, mast extended ⁽²⁾	h ₄ (mm)	-	-	2664	
4.7		Height of overhead guard (cabin) ⁽²⁾	h ₆ (mm)	1957 ⁽¹¹⁾	1957 ⁽¹¹⁾	-	
4.8		Seat height relating to SIP/stand height	h ₇ (mm)	180	180	180	
4.11		Additional lift	h ₉ (mm)	-	-	690	
4.14		Stand height, elevated	h ₁₂ (mm)	-	-	1190	
4.15		Height, lowered	h ₁₃ (mm)	80 ⁽³⁾	80 ⁽³⁾	80	
4.19		Overall length ⁽¹⁾ ⁽⁸⁾	l ₁ (mm)	2907	2907	2874	
4.20		Length to face of forks ⁽¹⁾ ⁽⁸⁾	l ₂ (mm)	1767	1767	1719	
4.21		Overall width ⁽⁴⁾	b ₁ /b ₂ (mm)	796	796	780	
4.22		Fork dimensions DIN ISO 2331 ⁽⁵⁾	s/e/l (mm)	60 / 180 / 1140	60 / 180 / 1140	60 / 180 / 1155	
4.23		Fork carriage ISO 2328, class/type A, B		No	No	No	
4.24		Fork-carriage width ⁽⁶⁾	b ₃ (mm)	700	700	-	
4.25		Distance between fork-arms ⁽⁷⁾	b ₅ (mm)	560	560	526	
4.31		Ground clearance, laden, below mast	m ₁ (mm)	135	135	135	
4.32		Ground clearance, center of wheelbase	m ₂ (mm)	30	30	30	
4.33		Load dimension b ₁₂ x l ₆ lengthwise	b ₁₂ x l ₆ (mm)	800 x 1200	800 x 1200	800 x 1200	
4.34.1		Aisle width for pallets 1000mm x 1200mm crossways ⁽¹⁷⁾	A _{st} (mm)	3256	3256	3277	
4.34.2	Aisle width for pallets 800mm x 1200mm lengthwise ⁽¹⁷⁾	A _{st} (mm)	3224	3224	3245		
4.35	Turning radius	W _a (mm)	1622	1622	1622		
Performance data	5.1	Travel speed, laden/unladen	km/h	10.1 / 10.4	10.1 / 10.4	10.1 / 10.5	
	5.2	Lift speed, laden/unladen (Cab)	m/s	-	-	0.17 / 0.25	
	5.2	Lift speed, laden/unladen (SL)	m/s	0.09 / 0.18	.09 / 0.18	-	
	5.3	Lowering speed, laden/unladen (Cab)	m/s	-	-	0.29 / 0.25	
	5.3	Lowering speed, laden/unladen (SL)	m/s	0.20 / 0.07	.20 / 0.07	-	
	5.7	Gradeability, laden/unladen	%	5 / 8	5 / 8	5 / 8	
	5.8	Max. gradeability, laden/unladen	%	5 / 8	5 / 8	5 / 8	
	5.9	Acceleration time, laden/unladen	s	5.5 / 7.5	5.5 / 7.5	5.5 / 7.5	
	5.10	Service brake		Electromagnetic	Electromagnetic	Electromagnetic	
Electric-engine	6.1	Drive motor S2 60 minute rating	km/h	4	4	4	
	6.2	Lift motor, S3 15% rating	km/h	2	3	3	
	6.3	Battery according to DIN 43531/35/36 A,B,C, no		no	no	no	
	6.4	Battery voltage/nominal capacity K5	(V) / Ah	24 / 500	24 / 500	24 / 620 ⁽¹⁰⁾	
	6.5	Battery weight ⁽⁹⁾	kg	370	370	485	
	6.6	Energy consumption according to VDI cycle	kWh/h @ no. of cycles	2.28	2.35	2.30	
8.1	Type of drive unit		AC-Controller	AC-Controller	AC-Controller		
10.7	Sound pressure level at the driver's seat	dB (A)	< 70	< 70	< 70		

⁽¹⁾ Note for SL model:
With FEM carriage and forks 80 x 30mm + 20mm.
With FEM carriage and forks 100 x 35mm + 25mm

⁽²⁾ Note for models with over head guard:
With Lift Interrupt mounted on OHG h₆ + 80mm

⁽³⁾ Note for SL model: With FEM carriage and forks 80 x 30mm and 100 x 35mm h₁₃ = 40mm

⁽⁴⁾ Note for SL model: With FEM carriage b₂ = 800mm

⁽⁵⁾ Note for SL model:
Available also FEM carriage and fork size 80 x 30mm (600Kg @ 600mm, 800Kg @ 500mm, 1000Kg @ 400mm) and 100 x 35mm with 1000Kg @ 600mm

⁽⁶⁾ Note for SL model: With FEM carriage b₃ = 800mm

⁽⁷⁾ Note for SL model:
With FEM carriage and forks 80 x 30mm b₅ = 753mm.
With FEM carriage and forks 100 x 35mm b₅ = 773mm

⁽⁸⁾ With wire guidance l₁ and l₂ + 40mm

⁽⁹⁾ These values may vary of +/- 5%

⁽¹⁰⁾ Available battery 560Ah. With battery 560Ah service weight -9kg

⁽¹¹⁾ Model without cabin; the value is referred to the overall height, without load backrest

⁽¹²⁾ Models name referred to h₁₂

⁽¹³⁾ Available models MO10E 19 SL

Yale	Yale	Yale	Yale		Manufacturer (abbreviation)	1.1	Distinguishing mark
MO10E 17 SL ⁽¹³⁾	MO10E 17 WP ⁽¹⁴⁾	MO10E 48 SL ⁽¹⁵⁾	MO10E 48 WP ⁽¹⁶⁾		Manufacturer's type designation	1.2	
Electric (battery)	Electric (battery)	Electric (battery)	Electric (battery)		Drive: electric (battery or mains), diesel, petrol, fuel gas	1.3	
Order-picker	Order-picker	Order-picker	Order-picker		Operator type: hand, pedestrian, standing, seated, order-picker	1.4	
1.0	1.0	1.0	1.0	Q (t)	Rated capacity/Rated load	1.5	
600	600	600	600	c (mm)	Load centre distance	1.6	
166	166	157	166	x (mm)	Load distance, centre of drive axle to fork ⁽¹⁾	1.8	
1390	1390	1510	1510	y (mm)	Wheelbase	1.9	
1800	2000	2736	2875	kg	Service weight ⁽⁹⁾ ⁽¹⁰⁾	2.1	
350 / 2450	350 / 2650	1034 / 2702	1223 / 2652	kg	Axle loading, laden front/rear	2.2	
950 / 850	950 / 1050	1523 / 1213	1755 / 1120	kg	Axle loading, unladen front/rear	2.3	
Vulkollan / Vulkollan	Vulkollan / Vulkollan	Vulkollan / Vulkollan	Vulkollan / Vulkollan		Tyres: polyurethane, tophane, vulkollan, front/rear	3.1	Tyres/chassis
254 x 125	254 x 125	254 x 125	254 x 125	ř (mm x mm)	Tyre size, front	3.2	
125 x 94	125 x 94	125 x 94	125 x 94	ř (mm x mm)	Tyre size, rear	3.3	
1x / 2	1x / 2	1x / 2	1x / 2		Wheels, number front/rear (x = driven wheels)	3.5	
660	660	830	830	b ₁₁ (mm)	Tread, rear	3.7	
2270	2270	3075	3075	h ₁ (mm)	Height, mast lowered	4.2	Dimensions
1510	1510	4628	4628	h ₃ (mm)	Lift	4.4	
3800	3800	6898	6898	h ₄ (mm)	Height, mast extended ⁽²⁾	4.5	
2270	2270	2270	2270	h ₆ (mm)	Height of overhead guard (cabin) ⁽²⁾	4.7	
180	180	180	180	h ₇ (mm)	Seat height relating to SIP/stand height	4.8	
690	-	690	-	h ₉ (mm)	Additional lift	4.11	
1710 ⁽¹²⁾	1710 ⁽¹²⁾	4808 ⁽¹²⁾	4808 ⁽¹²⁾	h ₁₂ (mm)	Stand height, elevated	4.14	
80 ⁽³⁾	80	80	80	h ₁₃ (mm)	Height, lowered	4.15	
2929	3099	3040	3220	l ₁ (mm)	Overall length ⁽¹⁾ ⁽⁸⁾	4.19	
1789	1789	1900	1910	l ₂ (mm)	Length to face of forks ⁽¹⁾ ⁽⁸⁾	4.20	
780	780 / 996	950	950 / 996	b ₁ /b ₂ (mm)	Overall width ⁽⁴⁾	4.21	
60 / 180 / 1140	60 / 180 / 1140	60 / 180 / 1140	60 / 180 / 1140	s/e/l (mm)	Fork dimensions DIN ISO 2331 ⁽⁵⁾	4.22	
No	No	No	No		Fork carriage ISO 2328, class/type A, B	4.23	
700	880	700	880	b ₃ (mm)	Fork-carriage width ⁽⁶⁾	4.24	
560	560	560	560	b ₅ (mm)	Distance between fork-arms ⁽⁷⁾	4.25	
135	135	135	135	m ₁ (mm)	Ground clearance, laden, below mast	4.31	
30	30	0	30	m ₂ (mm)	Ground clearance, center of wheelbase	4.32	
800 x 1200	800 x 1200	800 x 1200	800 x 1200	b ₁₂ x l ₆ (mm)	Load dimension b ₁₂ x l ₆ lengthwise	4.33	
3277	-	397	-	A _{st} (mm)	Aisle width for pallets 1000mm x 1200mm crossways ⁽¹⁷⁾	4.34.1	
3245	3377	3365	3497	A _{st} (mm)	Aisle width for pallets 800mm x 1200mm lengthwise ⁽¹⁷⁾	4.34.2	
1622	1622	1742	1742	W _a (mm)	Turning radius	4.35	
10.1 / 10.5	10.1 / 10.5	8.6 / 9.5	8.6 / 9.5	km/h	Travel speed, laden/unladen	5.1	Performance data
0.11 / 0.21	0.15 / 0.20	0.15 / 0.20	0.15 / 0.20	m/s	Lift speed, laden/unladen (Cab)	5.2	
0.09 / 0.18	-	0.09 / 0.18	-	m/s	Lift speed, laden/unladen (SL)	5.2	
0.26 / 0.14	0.28 / 0.24	0.27 / 0.23	0.28 / 0.24	m/s	Lowering speed, laden/unladen (Cab)	5.3	
0.20 / 0.07	-	0.20 / 0.,07	-	m/s	Lowering speed, laden/unladen (SL)	5.3	
5 / 8	5 / 8	5 / 8	5 / 8	%	Gradeability, laden/unladen	5.7	
5 / 8	5 / 8	5 / 8	5 / 8	%	Max. gradeability, laden/unladen	5.8	
5.5 / 7.5	5.5 / 7.5	5.5 / 7.5	5.5 / 7.5	s	Acceleration time, laden/unladen	5.9	
Electromagnetic	Electromagnetic	Electromagnetic	Electromagnetic		Service brake	5.10	
4	4	4	4	km/h	Drive motor S2 60 minute rating	6.1	Electric-engine
3	3	3	3	km/h	Lift motor, S3 15% rating	6.2	
no	no	no	no		Battery according to DIN 43531/35/36 A,B,C, no	6.3	
24 / 620 ⁽¹⁰⁾	24 / 620 ⁽¹⁰⁾	24 / 620 ⁽¹⁰⁾	24 / 620 ⁽¹⁰⁾	(V) / Ah	Battery voltage/nominal capacity K5	6.4	
485	485	485	485	kg	Battery weight ⁽⁹⁾	6.5	
2.40	2.40	2.86	2.90	kWh/h @ no. of cycles	Energy consumption according to VDI cycle	6.6	
AC-Controller	AC-Controller	AC-Controller	AC-Controller		Type of drive unit	8.1	
< 70	< 70	< 70	< 70	dB (A)	Sound pressure level at the driver's seat	10.7	

⁽¹⁴⁾ Available models MO10E 19 WP

⁽¹⁵⁾ Available models MO10E 32/36/40/44 SL

⁽¹⁶⁾ Available models MO10E 32/36/40/44 WP

⁽¹⁷⁾ Transfer aisle widths (lines 4.34.1 & 4.34.2) are based on the VDI standard calculation as shown on illustration.

The British Industrial Truck Association recommends the addition of 100 mm to the total clearance (dimension a) for extra operating margin at the rear of the truck.

All values are nominal values and they are subject to tolerances. For further information, please contact the manufacturer.

Yale products might be subject to change without notice

Lift trucks illustrated may feature optional equipment.

Values may vary with alternative configurations.

Truck Dimensions - MO10E 7 FC

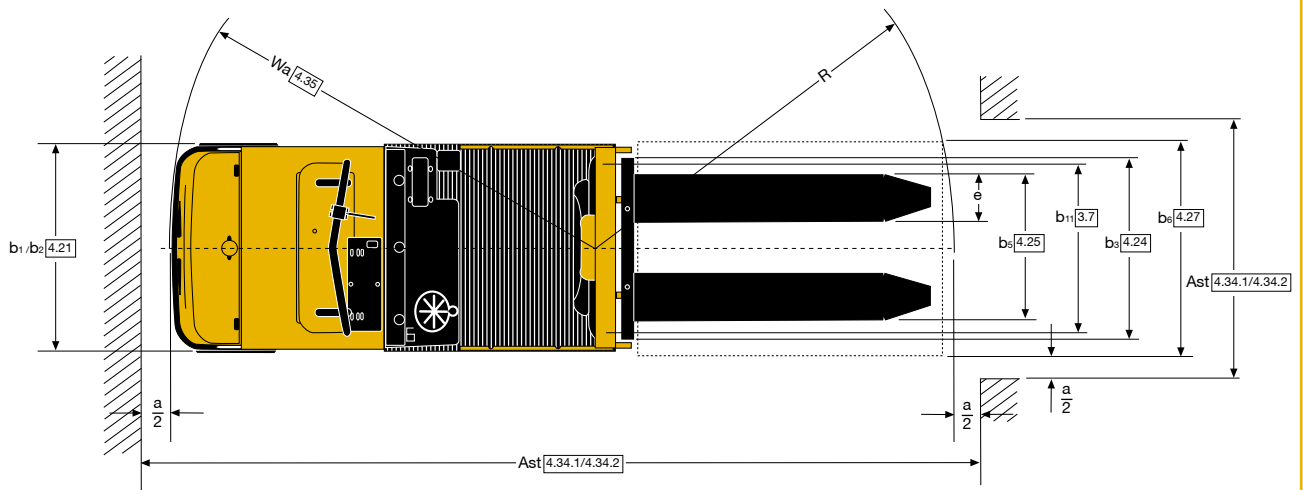
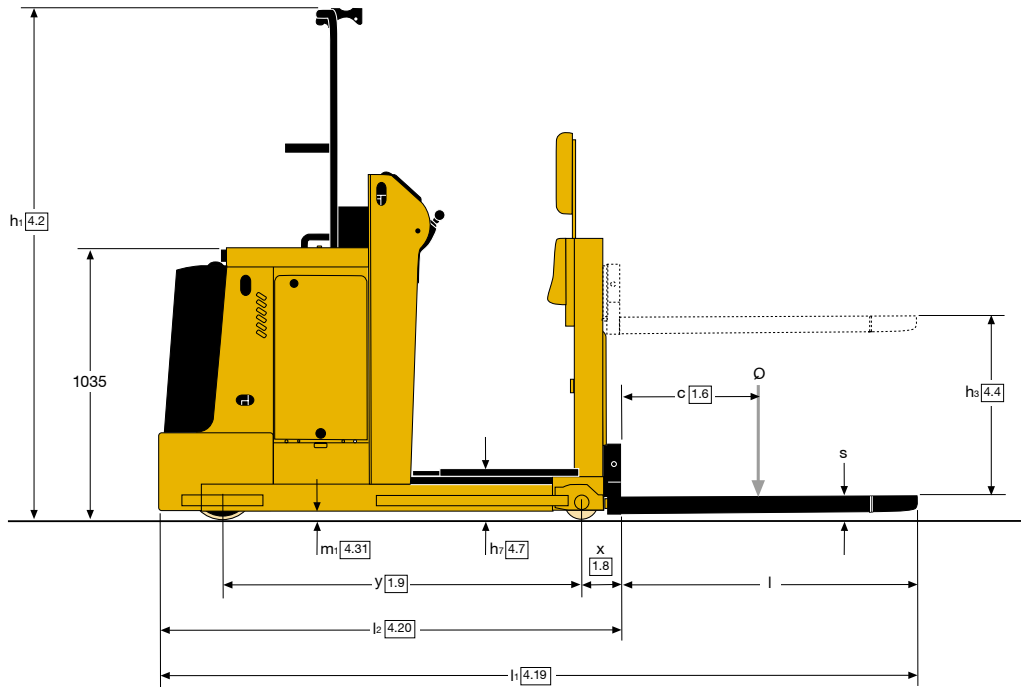

MO10E Mast details - 2 stage SL

Lift height h_3 (mm)	Fork lift H (mm)	Height, mast lowered h_1 (mm)	Height, mast extended h_4 (mm)	Stand height, elevated h_{12} (mm)
1010	1750	1654	2664	1190
1530	2270	2270	3800	1710
1690	2430	2270	3960	1870

Truck Dimensions - MO10E 14 FC

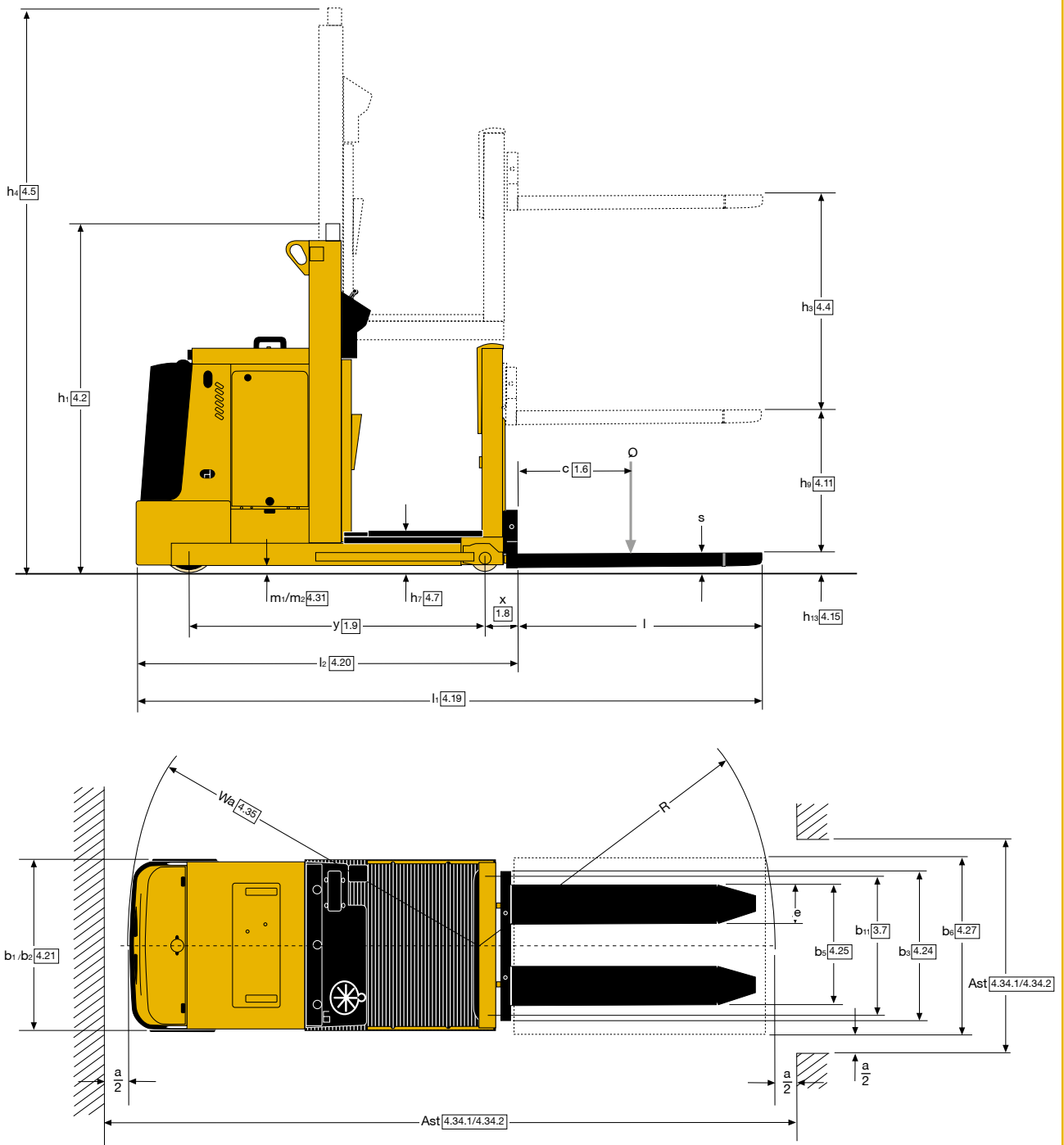

MO10E Mast details - 2 stage WP

Lift height h_3 (mm)	Fork lift H (mm)	Height, mast lowered h_1 (mm)	Height, mast extended h_4 (mm)	Stand height, elevated h_{12} (mm)
3028	3798	2275	5298	3208
3428	4198	2475	5698	3608
3828	4598	2675	6098	4008
4228	4998	2875	6498	4408
4628	5398	3075	6898	4808

Truck Dimensions - MO10E 17SL, MO10E 17WP

Note:

Grey parts of drawing, dimension lines and reference numbers denote MO10E 17WP model.

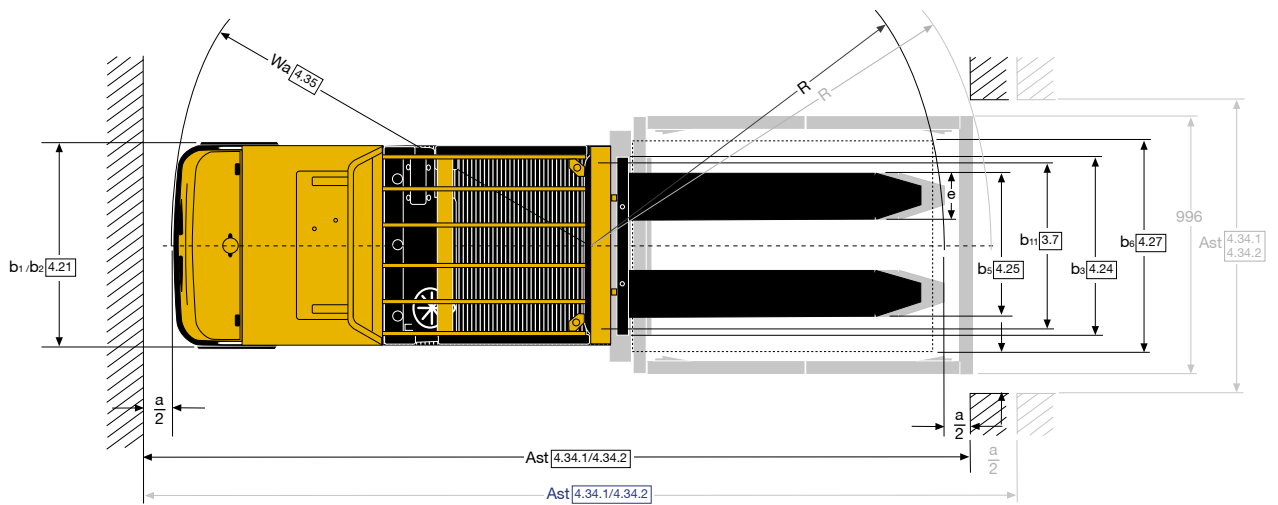
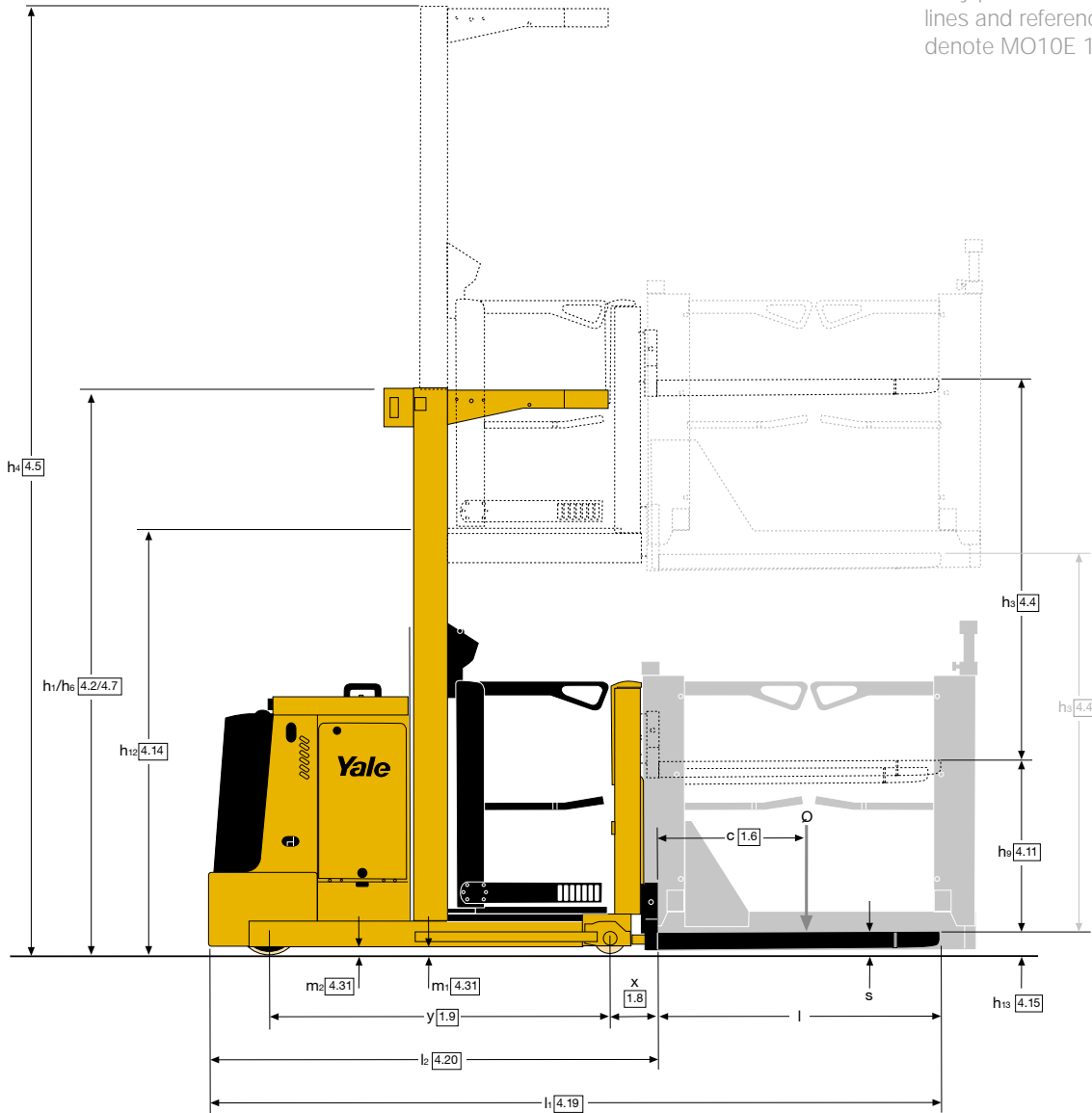

Truck Dimensions - MO10E 48 WP

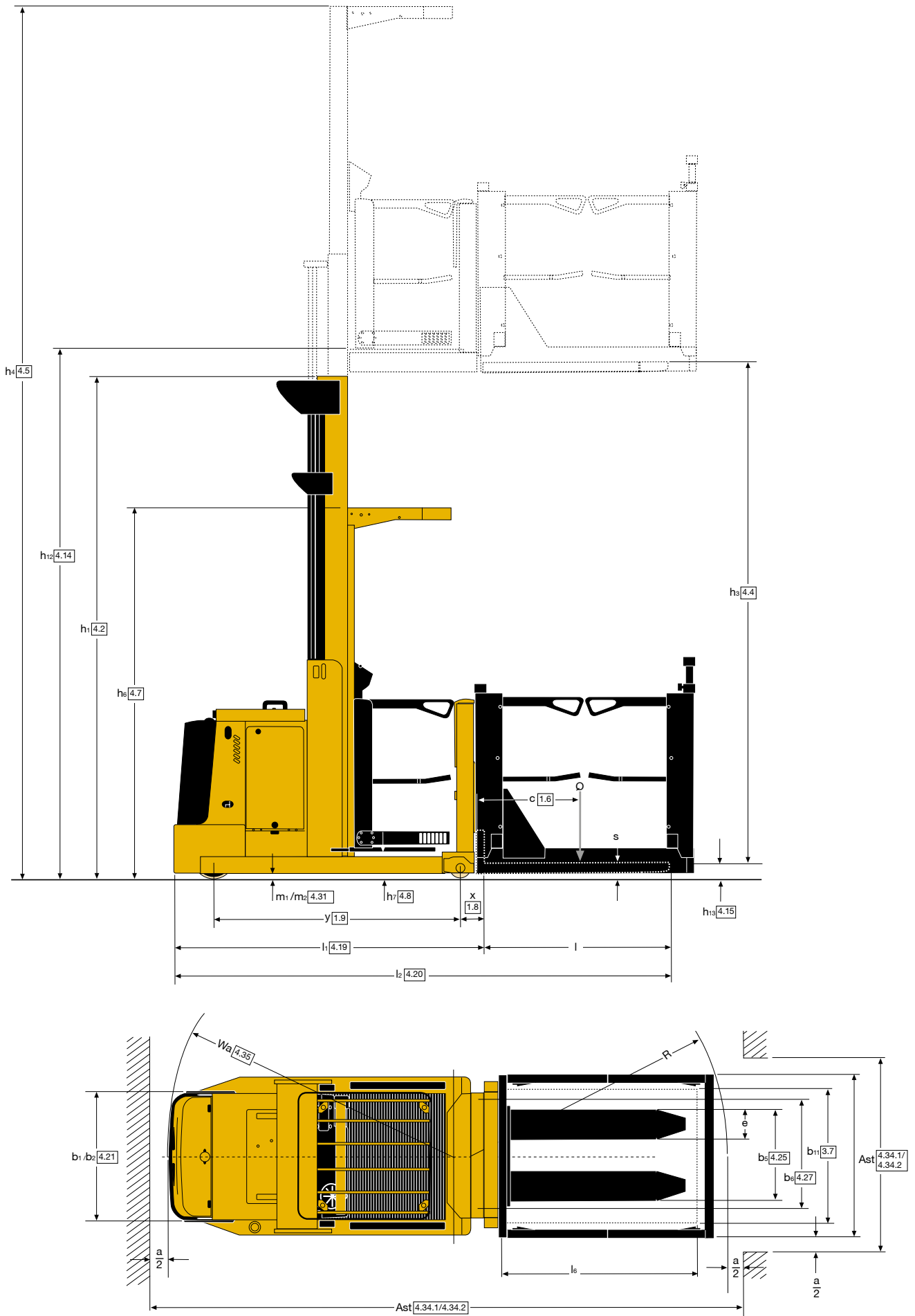

VDI 2198 General Specifications - MO10, MO10S

Distinguishing mark	1.1	Manufacturer (abbreviation)		Yale	Yale	Yale	
	1.2	Manufacturer's type designation		MO10	MO10S	MO10S	
	1.3	Drive: electric (battery or mains), diesel, petrol, fuel gas		Electric (battery)	Electric (battery)	Electric (battery)	
	1.4	Operator type: hand, pedestrian, standing, seated, order-picker		Order-picker	Order-picker	Order-picker	
	1.5	Rated capacity/Rated load	Q (t)	1.0	1.0	1.0	
	1.6	Load centre distance	c (mm)	600	600	600	
	1.8	Load distance, centre of drive axle to fork ⁽¹⁾	x (mm)	190	150 ⁽²⁾	150 ⁽³⁾	
	1.9	Wheelbase	y (mm)	1534.5	1574.5	1674.5	
	Weights	2.1	Service weight ⁽¹⁸⁾	kg	2890	3259	4073
2.2		Axle loading, laden front/rear	kg	1060 / 2830	1509 / 2750	1763 / 3310	
2.3		Axle loading, unladen front/rear	kg	1650 / 1240	1942 / 1317	2204 / 1869	
Tyres/chassis	3.1	Tyres: polyurethane, tophane, vulkollan, front/rear		Vulkollan / Vulkollan	Vulkollan / Vulkollan	Vulkollan / Vulkollan	
	3.2	Tyre size, front	ř (mm x mm)	343 x 140	343 x 140	343 x 140	
	3.3	Tyre size, rear	ř (mm x mm)	200 x 80	200 x 80	200 x 100	
	3.5	Wheels, number front/rear (x = driven wheels)		1 x / 2	1 x / 2	1 x / 2	
	3.7	Tread, rear	b ₁₁ (mm)	877	977	1057	
	Dimensions	4.2	Height, mast lowered	h ₁ (mm)	3070	3320	3720
		4.4	Lift	h ₃ (mm)	4670	5170	8895
4.5		Height, mast extended ^{(4) (5)}	h ₄ (mm)	7040	7540	11265	
4.7		Height of overhead guard (cabin) ^{(4) (5)}	h ₆ (mm)	2370	2370	2370	
4.8		Seat height relating to SIP/stand height	h ₇ (mm)	250	250	250	
4.11		Additional Lift	h ₉ (mm)	770	770	770	
4.14		Stand height, elevated	h ₁₂ (mm)	4920	5420	9145	
4.15		Height, lowered ⁽⁶⁾	h ₁₃ (mm)	80	80	80	
4.19		Overall length ⁽¹⁾	l ₁ (mm)	3087	3087	3242	
4.20		Length to face of forks ⁽¹⁾	l ₂ (mm)	1947	1947	1947	
4.21		Overall width	b ₁ /b ₂ (mm)	1000 / 1000	1100 / 1100	1100 / 1200	
4.22		Fork dimensions ⁽⁷⁾	s/e/l (mm)	60 / 180 / 1140	60 / 180 / 1140	60 / 180 / 1140	
4.23		Fork carriage ISO 2328, class/type A, B		No	No	No	
4.24		Fork-carriage width ⁽⁸⁾	b ₃ (mm)	780 ⁽¹⁴⁾	780 ⁽¹⁴⁾	780 ⁽¹⁴⁾	
4.25		Distance between fork-arms ⁽⁹⁾	b ₅ (mm)	560 ⁽¹⁵⁾	560 ⁽¹⁵⁾	560 ⁽¹⁵⁾	
4.27		Width across guide rollers	b ₆ (mm)	1130 ⁽¹⁶⁾	1230 ⁽¹⁶⁾	1430 ⁽¹⁶⁾	
4.31		Ground clearance, laden, below mast	m ₁ (mm)	80	80	80	
4.32		Ground clearance, centre of wheelbase ⁽¹⁰⁾	m ₂ (mm)	60	60	60	
4.33		Load dimension b ₁₂ x l ₆ lengthwise	b ₁₂ x l ₆ (mm)	800 x 1200	800 x 1200	800 x 1200	
4.34.1	Transfer aisle width for pallets 1000mm x 1200mm lengthwise ⁽¹⁹⁾	A _{st} (mm)	4737	4816	5015		
4.34.2	Transfer aisle width for pallets 800mm x 1200mm lengthwise ⁽¹⁹⁾	A _{st} (mm)	4721	4800	4999		
4.35	Turning radius	W _a (mm)	1757	1797	1897		
Performance data	5.1	Travel speed, laden/unladen	km/h	8.8 / 9	8.8 / 9	8.8 / 9	
	5.2	Lift speed, laden/unladen (Cab)	m/s	0.35 / 0.42	0.31 / 0.42	0.31 / 0.42	
	5.2	Lift speed, laden/unladen (SL)	m/s	0.22 / 0.24	0.2 / 0.24	0.2 / 0.24	
	5.3	Lowering speed, laden/unladen (Cab)	m/s	0.37 / 0.37	0.38 / 0.38	0.38 / 0.38	
	5.3	Lowering speed, laden/unladen (SL)	m/s	0.14 / 0.12	0.14 / 0.12	0.14 / 0.12	
	5.7	Gradeability, laden/unladen	%	6.3	6.2	5.8	
	5.10	Service brake		Electromagnetic	Electromagnetic	Electromagnetic	
Electric engine	6.1	Drive motor S2 60 minute rating	kW	6.4	6.4	6.4	
	6.2	Lift motor, S3 15% rating	kW	12	12	12	
	6.3	Battery according to DIN 43531/35/36 A,B,C, no		no	DIN 43531 B	DIN 43531 B	
	6.4	Battery voltage/nominal capacity K5	(V)/(Ah)	48 / 310 ⁽¹¹⁾	48 / 465 ⁽¹²⁾	48 / 620 ⁽¹³⁾	
	6.5	Battery weight ⁽¹⁸⁾	kg	541	750	945	
	6.6	Energy consumption according to VDI cycle	kWh/h @ no. of cycles	3.27kW	3.27kW	3.27kW	
8.1	Type of drive unit		AC-Controller	AC	AC		
10.7	Sound pressure level at the driver's seat	dB (A)	59	59	59		

⁽¹⁾ With FEM carriage and Forks 100 x 35 add + 25mm
⁽²⁾ With 3 stage mast add 55mm
⁽³⁾ With 2 stage mast reduce 55mm
⁽⁴⁾ With Lift Interrupt mounted on OHG: h₆ and h₄ are increased by 105mm
⁽⁵⁾ With flashing light fitted on Over Head Guard: h₆ and h₄ are increased by 120mm
⁽⁶⁾ With Fem like carriage and Forks 80 x 30 and 100 x 35 h₁₃ = 40mm
⁽⁷⁾ Available also FEM carriage and fork size 100 x 35 with 1000Kg @ 600mm

⁽⁸⁾ With FEM carriage b₃ = 800mm
⁽⁹⁾ With FEM carriage and Forks 100 x 35 b₅ max = 773mm
⁽¹⁰⁾ Sensor height 30mm from the ground
⁽¹¹⁾ Additional battery available: 48/280 (541kg)
⁽¹²⁾ Additional battery available: 48/420 (746kg)
⁽¹³⁾ Additional battery available: 48/560 (937kg)
⁽¹⁴⁾ Available 700mm and 860mm
⁽¹⁵⁾ Available 520mm, 680mm, 830mm
⁽¹⁶⁾ Available 1075mm and 1330mm
⁽¹⁷⁾ Available 1175mm and 1430mm

⁽¹⁸⁾ These values may vary of +/- 5%
⁽¹⁹⁾ Transfer aisle widths (lines 4.34.1 & 4.34.2) are based on the VDI standard calculation as shown on illustration. The British Industrial Truck Association recommends the addition of 100mm to the total clearance (dimension a) for extra operating margin at the rear of the truck.
All values are nominal values and they are subject to tolerances. For further information, please contact the manufacturer.
Yale products might be subject to change without notice.
Lift trucks illustrated may feature optional equipment.
Values may vary with alternative configurations.

VDI 2198 General Specifications - MO10S WP

Distinguishing mark	1.1	Manufacturer (abbreviation)		Yale	Yale
	1.2	Manufacturer's type designation		MO10S WP	MO10S WP
	1.3	Drive: electric (battery or mains), diesel, petrol, fuel gas		Electric (battery)	Electric (battery)
	1.4	Operator type: hand, pedestrian, standing, seated, order-picker		Order-picker	Order-picker
	1.5	Rated capacity/Rated load	Q (t)	1.0	1.0
	1.6	Load centre distance	c (mm)	600	600
	1.8	Load distance, centre of drive axle to fork	x (mm)	162.5	162.5
	1.9	Wheelbase	y (mm)	1574.5	1674.5
	Weights	2.1	Service weight ⁽⁵⁾	kg	3343
2.2		Axle loading, laden front/rear	kg	1539 / 2804	1573 / 3588
2.3		Axle loading, unladen front/rear	kg	19920 / 1351	2154 / 2007
Tyres/chassis	3.1	Tyres: polyurethane, tophane, vulkollan, front/rear		Vulkollan / Vulkollan	Vulkollan / Vulkollan
	3.2	Tyre size, front	ř (mm x mm)	343 x 140	343 x 140
	3.3	Tyre size, rear	ř (mm x mm)	200 x 80	200 x 100
	3.5	Wheels, number front/rear (x = driven wheels)		1 x / 2	1 x / 2
	3.7	Track width, rear	b ₁₁ (mm)	977	1057
Dimensions	4.2	Height, mast lowered	h ₁ (mm)	3320	3470
	4.4	Lift	h ₃ (mm)	5170	8145
	4.5	Height, mast extended ^{(1) (2)}	h ₄ (mm)	7540	10515
	4.7	Height of overhead guard (cabin) ^{(1) (2)}	h ₆ (mm)	2370	2370
	4.8	Seat height relating to SIP/stand height	h ₇ (mm)	250	250
	4.14	Stand height, elevated	h ₁₂ (mm)	5420	8395
	4.15	Height, lowered	h ₁₃ (mm)	80	80
	4.19	Overall length	l ₁ (mm)	3260	3360
	4.20	Length to face of forks	l ₂ (mm)	1960	2060
	4.21	Overall width	b ₁ /b ₂ (mm)	1100 / 1100	1100 / 1200
	4.22	Fork dimensions	s/e/l (mm)	60 / 180 / 1150	60 / 180 / 1150
	4.23	Fork carriage ISO 2328, class/type A, B		No	No
	4.24	Fork-carriage width	b ₃ (mm)	1080	1280
	4.25	Distance between fork-arms	b ₅ (mm)	560	560
	4.27	Width across guide rollers	b ₆ (mm)	1230 ⁽⁶⁾	1430
	4.31	Ground clearance, laden, below mast	m ₁ (mm)	80	80
4.32	Ground clearance, centre of wheelbase	m ₂ (mm)	60	60	
4.33	Load dimension b ₁₂ x l ₆ lengthwise	b ₁₂ x l ₆ (mm)	1000 x 1200	1200 x 1200	
4.34	Transfer aisle width ⁽⁷⁾	A _{st} (mm)	3575	3715	
4.35	Turning radius	W _a (mm)	1798	1898	
Performance data	5.1	Travel speed, laden/unladen	km/h	8.8 / 9	8.8 / 9
	5.2	Lift speed, laden/unladen (Cab)	m/s	0.37 / 0.43	0.37 / 0.43
	5.3	Lowering speed, laden/unladen (Cab)	m/s	0.38 / 0.38	0.38 / 0.38
	5.7	Gradeability, laden/unladen	%	-	-
	5.10	Service brake		Electromagnetic	Electromagnetic
Electric engine	6.1	Drive motor, S2 60 minute rating	kW	6.4	6.4
	6.2	Lift motor S3 15% rating	kW	12	12
	6.3	Battery according to DIN 43531/35/36 A,B,C, no		DIN 43531 B	DIN 43531 B
	6.4	Battery voltage/nominal capacity K5	V/Ah	48 / 465 ⁽³⁾	48 / 620 ⁽⁴⁾
	6.5	Battery weight ⁽⁵⁾	kg	750	945
	6.6	Energy consumption according to VDI cycle	kWh/h	3.27kW	3.27kW
8.1	Type of drive unit		AC-Controller	AC-Controller	
10.7	Sound pressure level at the driver's seat	dB (A)	< 70	< 70	

⁽¹⁾ With Lift Interrupt mounted on Over Head Guard h₆ and h₄ are increased by 105mm

⁽²⁾ With flashing light fitted on Over Head Guard h₆ and h₄ are increased by 120mm

⁽³⁾ Additional battery available: 48/420 (746kg)

⁽⁴⁾ Additional batterie available: 48/560 (937kg)

⁽⁵⁾ These values may vary of +/- 5%

⁽⁶⁾ Available 1175mm and 1430mm

⁽⁷⁾ Transfer aisle widths (lines 4.34.1 & 4.34.2) are based on the VDI standard calculation as shown on illustration. The British Industrial Truck Association recommends the addition of 100 mm to the total clearance (dimension a) for extra operating margin at the rear of the truck.

All values are nominal values and they are subject to tolerances.

For further information, please contact the manufacturer.

Yale products might be subject to change without notice.

Lift trucks illustrated may feature optional equipment. Values may vary with alternative configurations.

MO10, MO10S Mast details - 2 stage SL

Lift height h ₃ (mm)	Fork lift H (mm)	Height, mast lowered h ₁ (mm)	Height, mast extended h ₄ (mm)	Stand height, elevated h ₁₂ (mm)
3270	4130	2370	5640	3520
3370	4230	2420	5740	3620
3470	4330	2470	5840	3720
3570	4430	2520	5940	3820
3670	4530	2570	6040	3920
3770	4630	2620	6140	4020
3870	4730	2670	6240	4120
3970	4830	2720	6340	4220
4070	4930	2770	6440	4320
4170	5030	2820	6540	4420
4270	5130	2870	6640	4520
4370	5230	2920	6740	4620
4470	5330	2970	6840	4720
4570	5430	3020	6940	4820
4670	5530	3070	7040	4920
4770	5630	3120	7140	5020
4870	5730	3170	7240	5120
4970	5830	3220	7340	5220
5070	5930	3270	7440	5320
5170	6030	3320	7540	5420
5270	6130	3370	7640	5520
5370	6230	3420	7740	5620
5470	6330	3470	7840	5720
5570	6430	3520	7940	5820
5670	6530	3570	8040	5920
5770	6630	3620	8140	6020
5870	6730	3670	8240	6120
5970	6830	3720	8340	6220
6070	6930	3770	8440	6320
6170	7030	3820	8540	6420
6270	7130	3870	8640	6520
6370	7230	3920	8740	6620
6470	7330	3970	8840	6720
6570	7430	4020	8940	6820
6670	7530	4070	9040	6920

MO10, MO10S Mast details - 3 stage SL

Lift height h ₃ (mm)	Fork lift H (mm)	Height, mast lowered h ₁ (mm)	Height, mast extended h ₄ (mm)	Stand height, elevated h ₁₂ (mm)
4845	5705 ⁽¹⁾	2370	7215	5095
4995	5855	2420	7365	5245
5145	6005 ⁽¹⁾	2470	7515	5395
5295	6155	2520	7665	5545
5445	6305	2570	7815	5695
5595	6455	2620	7965	5845
5745	6605 ⁽¹⁾	2670	8115	5995
5895	6755	2720	8265	6145
6045	6905	2770	8415	6295
6195	7055	2820	8565	6445
6345	7205 ⁽¹⁾	2870	8715	6595
6495	7355	2920	8865	6745
6645	7505	2970	9015	6895
6795	7655	3020	9165	7045
6945	7805 ⁽¹⁾	3070	9315	7195
7095	7955	3120	9465	7345
7245	8105	3170	9615	7495
7395	8255	3220	9765	7645
7545	8405 ⁽¹⁾	3270	9915	7795
7695	8555	3320	10065	7945
7845	8705	3370	10215	8095
7995	8855	3420	10365	8245
8145	9005 ⁽¹⁾	3470	10515	8395
8295	9155	3520	10665	8545
8445	9305	3570	10815	8695
8595	9455	3620	10965	8845
8745	9605 ⁽¹⁾	3670	11115	8995
8895	9755	3720	11265	9145

⁽¹⁾ For models WP -780mm

Truck Dimensions - MO10, MO10S, MO10S WP

Note:

Grey parts of drawing, dimension lines and reference numbers denote MO10S WP model.

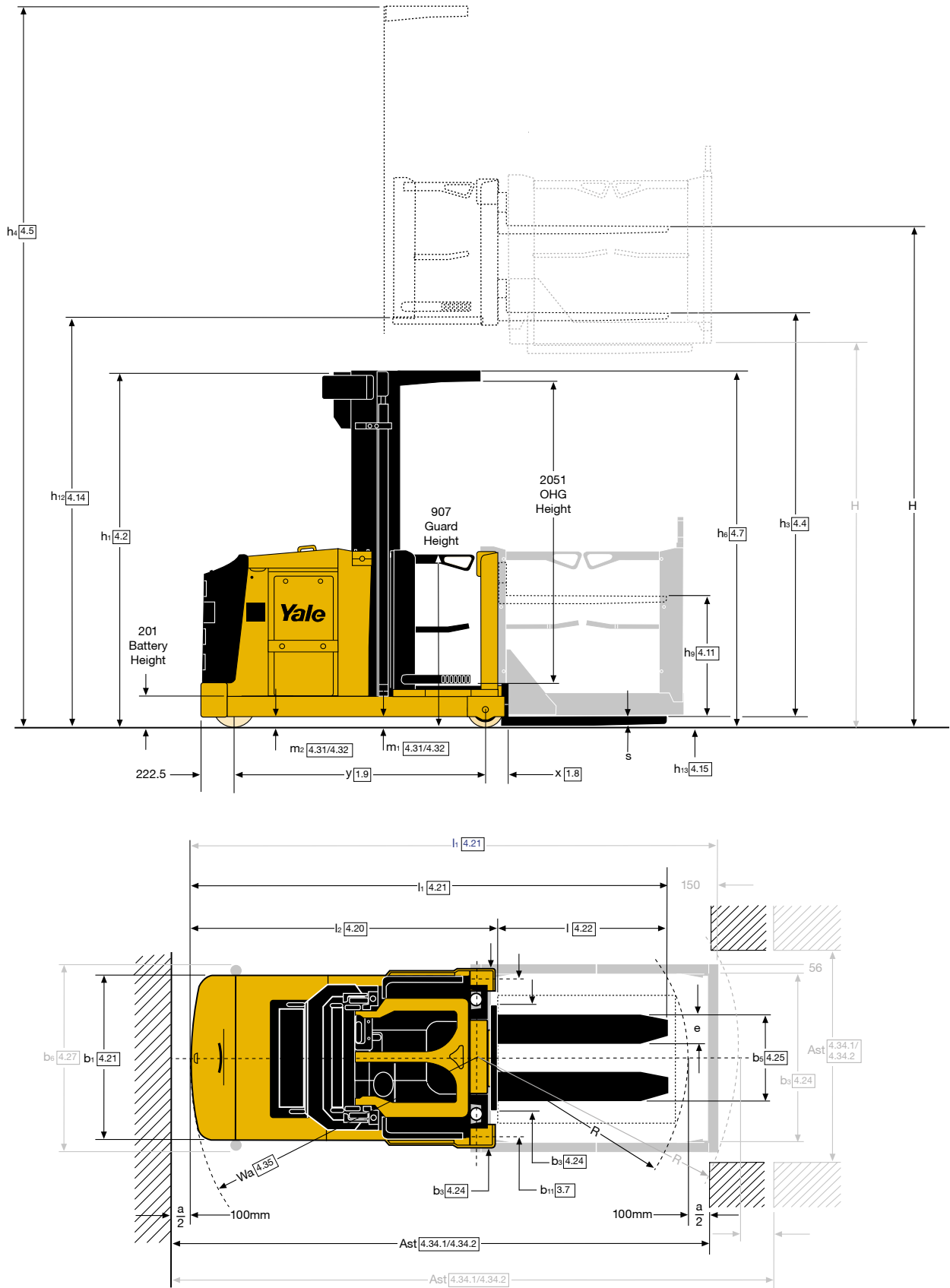

Standard Options and Optional Equipment

Feature	MO10E -7/14 FC	MO10E 12 SL/WP	MO10E 19-48 SL/WP	MO10	MO10 SL/WP
Operator's compartment					
Drive side facing controls	X	X	X	X	X
Dual drive and load side facing controls	-	-	-	o	o
Electric power steering	X	X	X	X	X
Floor integrated operator presence sensing	X	X	X	X	X
Height indicator	X	X	X	X	X
Storage compartments	X	X	X	X	X
Open operator's compartment - raised floor height (h12) < 1200 mm	-	X	-	-	-
Enclosed operator's compartment - front and sides	-	-	X	X	X
Fold-up bottom toe plate on side gates (enclosed compartment only)	-	-	X	X	X
Lift and traction					
Proportional lift/lower control	-	-	X	X	X
Soft stop on lowering	-	-	-	X	X
Emergency lowering from the ground	-	-	X	X	X
Driver select performance settings on traction and lift	X	X	X	X	X
Walk along slow speed advance control from side of truck	X	X	X	X	X
Off board lift / lower control of forks	X	X	X	X	X
Load handling					
Walk-on forks - open	-	X (WP)	-	-	-
Walk-on forks - pallet cage with fold-up side-gates / pallet sensing	-	-	X (WP)	-	o
Welded fixed forks - walk-on pallet option	-	X (WP)	X (WP)	-	o
Supplementary lift - fixed fork width	o (7 FC)	o (SL)	o (SL)	o	o
Supplementary lift - adjustable fork width	o (7 FC)	o (SL)	o (SL)	o	o
Masted lift - adjustable width forks	o (14 FC)	-	-	-	-
Load backrest	o	-	-	-	-
Travel					
Free ranging	X	X	X	X	X
Speed reduction on cornering	X	X	X	X	X
Height / load sensing speed control	-	-	-	X	X
Guide rollers for rail guidance (rail not included)	-	-	o ⁽¹⁾	o	o
Wire guidance (5.2 / 6.25 / 7.0 / 10 kHz)	-	-	o ⁽¹⁾	o	o
End of aisle control options (slow down / stop) via floor magnets	-	-	o ⁽¹⁾	o	o
Options					
Flashing beacon	o	o	o ⁽²⁾	X	X
Dome light	-	-	o	o	o ⁽³⁾
Fan	-	-	o	-	-
Dome light and fan	-	-	-	o	o
Work lights - facing racks	-	-	o	o	o
Work light - over load	-	-	o	o	o
Lexan overhead guard	-	-	o	o	o
Wire mesh overhead guard	-	-	o	o	o
Lift Interrupt with override	-	o	o	o	o
Lift Interrupt on overhead guard	-	-	o	o	o
Autostop on lowering	-	-	-	o	o
Reverse alarm	o	o	o	o	o
Cold store protection	o	o	o	o	o
Clipboard	o	-	o	o	o
RFDT hang -on support	o	o	o	o	o
DC/DC converter 12V	o	o	o	o	o
DC/DC converter 24V	-	-	-	o	o
Antistatic drive tyre	-	-	-	o	o
Configuration					
Cabin width (mm)	796	780	940	950	1050 - 1150 - 1240 ⁽⁴⁾
Chassis width b (mm)	796	780	950	1000	1100 - 1200 ⁽⁶⁾
Fixed cab / supplementary lift - 690 mm	MO10E 7	o	o	-	-
Fixed cab / masted fork lift - 1410 mm	MO10E 14	-	-	-	-
Rising cab 1 stage mast - raised platform height (h12) = 1190 mm	-	X	-	-	-
Rising cab 1 stage mast - raised platform height (h12) = 1690 - 1850mm	-	-	o	-	-
Rising cab 2 stage mast - raised platform height (h12) = 3207 - 4807mm	-	-	o	-	-
Rising cab 2 stage mast - raised platform height (h12) = 3620 - 4920mm	-	-	-	o	-
Rising cab 2 stage mast - raised platform height (h12) = 3620 - 6920mm	-	-	-	-	o
Rising cab 3 stage mast - raised platform height (h12) = 5095 - 9145mm	-	-	-	-	o ⁽⁵⁾
Power					
AC traction	X	X	X	X	X
AC steering	X	X	X	X	X
AC pump motor	-	-	-	X	X
Voltage	24	24	24	48	48
Battery size (Ah)	500	560-620	560-620	280-310	420-620
Regen on lowering	-	-	-	X	X
Battery rollers	X	X	X	X	X
Side battery change table- single bed	o	o	o	o	o
Side battery change table - twin bed	o	o	o ⁽⁶⁾	-	-

⁽¹⁾ With 2 stage mast only (Raised platform height (h12) = 3200mm - 4800 mm)

⁽²⁾ Required option (Raised platform height (h12) > 1200mm)

⁽³⁾ With 2 stage mast only

⁽⁴⁾ With walk-on pallet cage - 1140mm / 1340mm

⁽⁵⁾ From raised platform height (h12) = 8450mm, 1200mm chassis required

⁽⁶⁾ Not with rail guidance

x = Standard

o = Optional

- = Not available

MOE/S series



Models: MO10E 7, MO10E 14FC, MO10E 12, MO10E 12SL, MO10E 19SL, MO10E 19WP, MO10E 48SL, MO10E 48WP, MO10, MO10S SL, MO10S WP

Operator Compartment

The platform is cushioned to absorb vibrations, the bulkhead is angled and padded for access to the load support with a low step height for easy access.

MO10E Fixed Cab models have a non-raising cab open on two sides and forks with a lift height of 1500mm.

MO10E 12 models have a maximum cabin platform lifting height of 1200mm, open on three sides for direct access to the pallet/load with forks welded directly to the cabin floor structure.

MO10E Supplementary Lift (SL) models have a maximum cabin platform lifting height of 4800mm with pallet/load auxiliary lift.

MO10E Walk on Pallet (WP) models have fixed forks, with platform lifting heights of 4800mm. Side gates enclose the cage around the pallet - the cabin has its own spring assisted side gates. An integral toe board lifts up with the side arms to maintain a low step height for access. An abseil device is provided with the truck.

Chassis

Available in different widths, the short narrow chassis enhances manoeuvring facilitating two-way aisle traffic. An overhead guard is supplied for h12 higher than 1200mm.

MO10 model has a maximum cabin platform lifting height of 4920mm with pallet/load auxiliary lift.

MO10S models have a maximum cabin platform lifting height of 9145mm with pallet/load auxiliary lift, 6920mm with fixed forks (WP).

Controls

Controls location maximise the area of the platform for easy picking to either side. The butterfly switch controls travel speed, forward and reverse direction, mini-levers control the main lift/lower.

The CAN bus system with Hall effect sensors enhance truck performance, reduce wiring complexity, simplifying

service maintenance.

Graphic Display

The display shows steer wheel position, cabin platform height, traction speed, lifting-lowering speed, fault code display, battery status and preset performance levels. Additional information is accessible via a password for up to 20 operators

Steering

“Fly-by-wire” technology via the AC motor. The steering wheel is adjustable for feedback, automatically self-centring when the truck is turned on, or when the creep speed mode is activated.

Creep Speed Advance

The “pedestrian mode” creep speed function allows the operator to advance, lift or lower the platform whilst alongside the truck.

Supplementary lift

The supplementary carriage/forks are mounted on a bulkhead fitted to the operator’s compartment for auxiliary lift - control requires two-handed operation. The load can be raised or lowered for a comfortable working height.

Walk on Pallet cage (WP)

The WP model allows direct access to the pallet at heights over 1200mm, via two spring assisted swing-up gates. The metal cage allows full pick access from floor level. A fork-mounted pallet sensor prevents traction/lifting above 1200mm raised platform height with empty forks - interlocked side and cabin gates must be deployed above this height.

Mast

Panoramic design provides excellent visibility, a slack chain detector prevents further lowering if an obstacle is encountered. Lowering speed is automatically reduced as the cab nears the floor. The MO10/MO10S have two stage mast options, three stage on the MO10S and one stage on the MO10E.

Traction Steering Unit

The high torque AC traction motor provides fast acceleration with comparable unladen and laden travel speeds. The fixed, maintenance free motor and vertically mounted drive unit eliminate cable flexing and stress. Electronic combi MOSFET controllers manage traction and hoist, with excellent power management, consumption, acceleration and regenerative braking. Performance parameters are adjustable with an external handset. The controller features self diagnostics and thermal protection.

Hydraulic system

MOSFET control provides proportional handling for lifting and lowering of the cab and supplementary lift. Hose break valves prevent lowering in the event of a line break, a manual lowering valve allows emergency cab lowering to the ground.

Brakes

Releasing the butterfly control automatically brakes the drive motor. An electromagnetic parking brake is activated by a platform sensor. Fingertip control Emergency braking activates powerful reverse direction braking and the electromagnetic brake. If the operator leaves the platform, the emergency brake activates immediately.

Batteries

A flip up cover provides easy access for battery servicing which is mounted on rollers for left side extraction - a roller bed trolley is available as an option.

Guidance Options

Trucks may be free ranging or guided. On guided trucks maximum speed can be maintained to higher heights as the driver can simultaneously travel and lift or lower without having to steer. Options include wire-guidance package (includes sensors and a truck logic module linked to the steering system) or rollers for rail guidance.

Optional Extras

A wide range of options is available.

Yale Pacific

1/23 Rowood Road, Prospect NSW 2145
Tel: +61 (2) 9795 3800 | Fax: +61 (2) 9792 8484

Yale Asia

16 Tuas Avenue 20, Singapore 638827
Tel: +65 6863 3387 | Fax: +65 6863 3349

Yale, and PEOPLE. PRODUCTS. PRODUCTIVITY are trademarks of Hyster-Yale Group, Inc.  is a registered copyright of Hyster-Yale Group, Inc.

©Yale Asia Pacific 2022. All rights reserved. Specifications and details in this brochure are subject to change without prior notification.

www.yale.com



Manufactured in our own ISO 9001 and 14001 Registered Facilities

Trucks may be shown with optional equipment.

Yale 
People. Products. Productivity.™