

## PIPETITE® Standard For new tubing installations

Pipetite Standard is ideal for new tubing installations where the boot can slide over the end of the tubing before it is installed. It forms a flexible, sanitary seal that allows for pipeline movement. Its flexibility and self-sealing design eliminate the headaches that come with metal wall plates. Pre-drilled holes make installation simple, and a large range of sizes are available.

Self-sealing ridges are incorporated into the unique base design to provide excellent surface contact and eliminate the need to "pack" the product off the wall, so sealants and caulks are not required for installation. Pipetite can be adapted to fit most pipe or tube diameters and allows the pipe to move significantly without causing damage or breaking the seal between the wall and the pipe.



### Features

- Available in five sizes to suit 0 – 180mm tube or pipe
- Hygienic white silicone (FDA 21 CFR 177.2600)
- 316 stainless steel support ring
- Total self-sealing - no sealant required
- Seal is flexible to accommodate movement of pipe
- Temperature rating -40°C to +260°C
- No clean-up after installation
- Easily trimmed to size - moulded guide lines
- Materials compatible with cleaning solution
- Predrilled for quick and easy installation

### Industries

- Processed foods
- High-acid foods
- Dairy
- Beverages
- Breweries
- Home & personal care
- Pharmaceutical
- Biotech
- Chemical

Australian Distributors of:



## Specifications

<b>Materials:</b>	Hygienic white silicone 316 stainless steel
<b>Tube OD size range:</b>	0 – 180mm
<b>Minimum temperature:</b>	-40°C
<b>Maximum temperature:</b>	+260°C

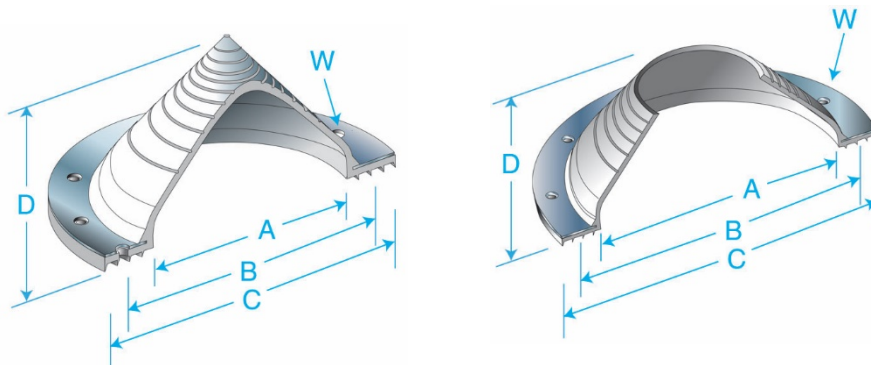

Pipette Standard						
Model	Tube OD mm	A mm	B mm	C mm	D mm	Anchors Needed
PT-0-35	0 - 25	30	57	70	52	4
PT-0-65	0 - 65	64	91	106	60	4
PT-0-95	0 - 95	100	128	147	78	6
PT-70-125	70 - 135	140	168	187	64	6
PT-100-150	100 - 180	180	213	237	84	10

Australian Distributors of:

