

# specifications

## PG800HC

SKOPE Pegasus Horizontal 2/1  
INTEGRAL 3 Door Chiller (JK2303)

### CABINET DIMENSIONS

	External	Internal
<b>Height:</b>	771mm*	565mm
<b>Width:</b>	2435mm	1935mm
<b>Depth:</b>	828mm	650mm
<b>Floor area:</b>	2.02m <sup>2</sup>	

\* Height includes plinth and worktop (excludes castors and adjustable legs).

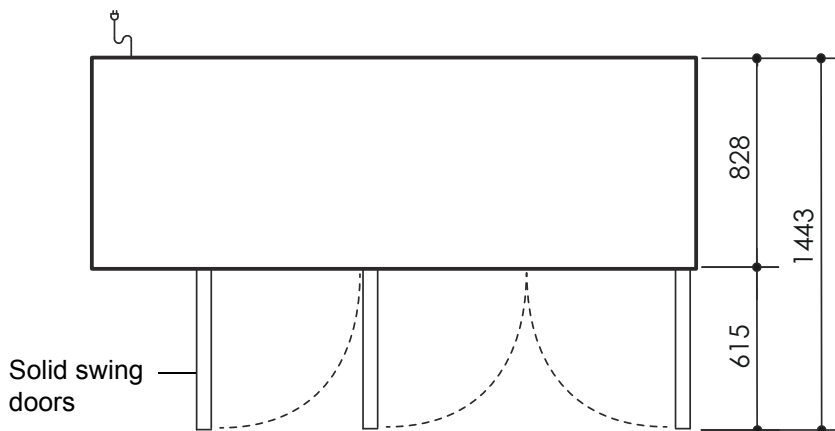

Pictured with optional 50mm stainless steel worktop

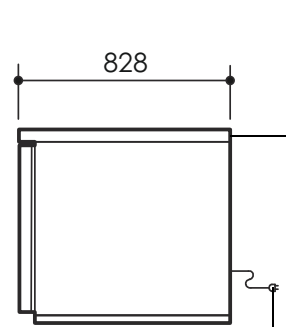
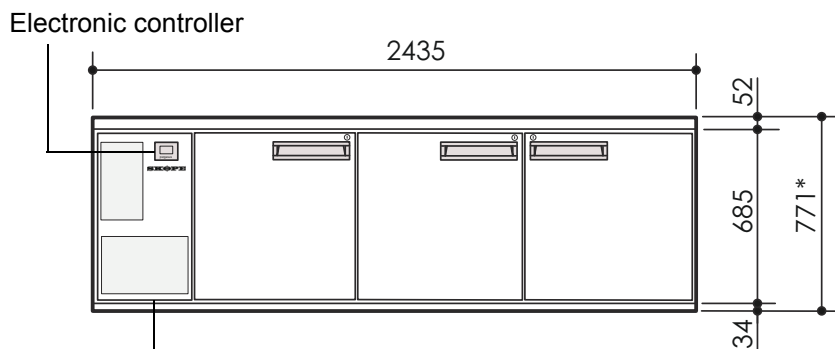

Side mounted integral refrigeration unit

Power cord with 3-Pin plug

Copyright © 2012 SKOPE Industries Limited

### CABINET SPECIFICATIONS

<b>Refrigeration system:</b>	Electronic controlled, side mounted, integral refrigeration unit
<b>Refrigerant:</b>	R134a / 530g
<b>Nominal capacity:</b>	599 Watts @ -10°C SST
<b>Cabinet internal volume:</b>	750 litres
<b>Insulation:</b>	60mm thick, high density cyclo-isopentane polyurethane foam
<b>Cabinet temperature range:</b>	+1°C to +4°C up to 43°C ambient
<b>Drainage:</b>	No plumbing required
<b>Electrical:</b>	230-240 Volts a.c. 50 Hz, 3.67 Amps
<b>Internal lighting:</b>	n.a.
<b>Internal door opening size:</b>	3 door openings: 565mm high x 565mm wide
<b>Door:</b>	Solid stainless steel, self-closing doors (with key lock) - LH & RH hinged
<b>Worktop (optional):</b>	Optional 50mm square edged stainless steel worktop
<b>Shelves:</b>	Two levels of non-tip, adjustable tray slides and/or shelves per door
<b>Weight:</b>	150 kg

SKOPE Industries Limited reserve the right to alter specifications without notice.

PSS0199 Rev 2.1 Mar. 2013



**SKOPE INDUSTRIES LIMITED**



New Zealand Freephone: 0800 947 5673, Fax: (03) 983 3896. Australian Freephone: 1800 121 535, Freefax: 1800 121 533

Email: enquiry@skope.co.nz Website: www.skope.co.nz