

SUR-CUT™ GUILLOTINE KNIFE ASSEMBLY

GH-1000



SUR-CUT™ GUILLOTINE KNIFE ASSEMBLY

GH-1000 TECHNICAL SPECIFICATION

Solid Models & Videos Available Online

AZCO Corp. offers complete, modular guillotine knife assemblies ready to install as stand-alone or in-line units. The GH series is a heavy duty unit that can be mounted in any position for convenient operation and cut a wide variety of flexible materials. Mounting holes allow quick installation. We also offer our GO Series for narrower material and our GC Series for mid-range material.

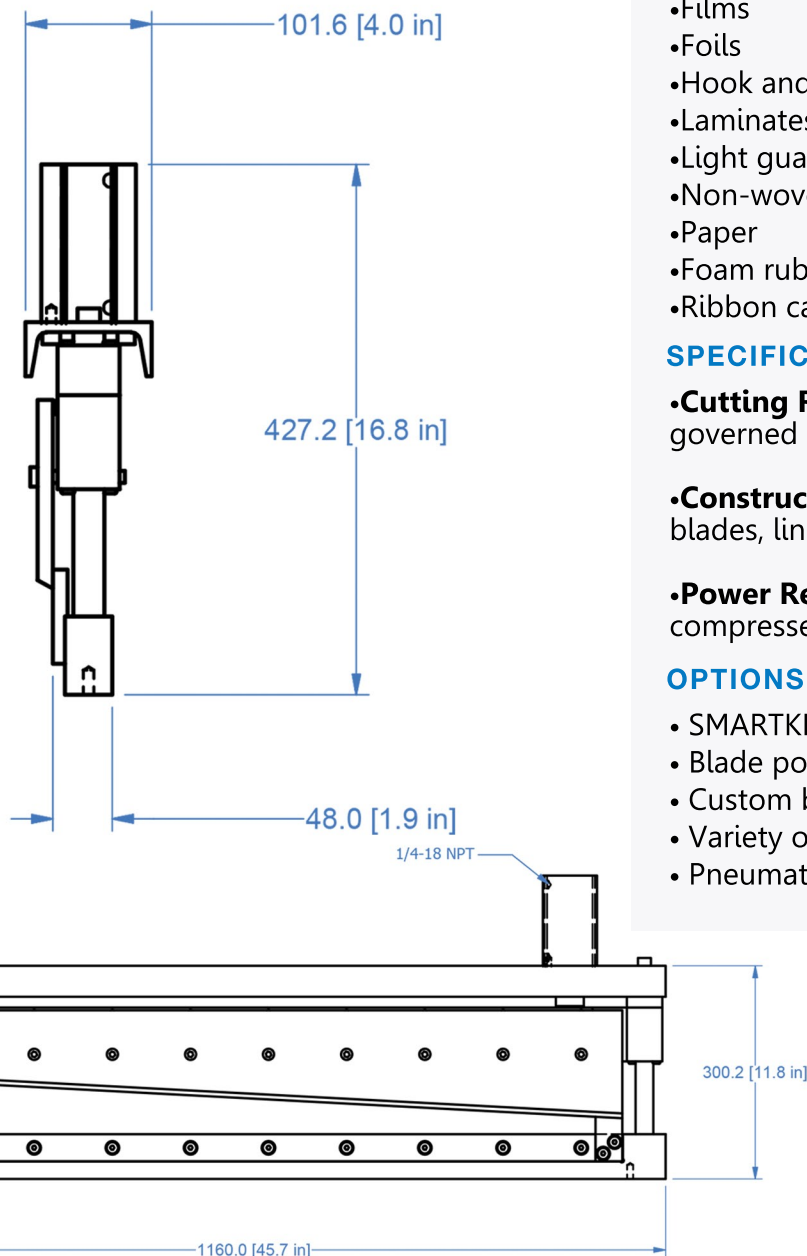

BENEFITS

- Proven off-the-shelf design
- Simple installation and hook-up
- Clean cuts
- Low maintenance
- Holes provided for mounting on flat, single-plane surfaces
- D2 hardened tool steel blades for long life

MATERIALS

- Films
- Foils
- Hook and loop
- Laminates
- Light gauge metals (.25mm/.01 in.)
- Non-wovens
- Paper
- Foam rubber
- Ribbon cables and many others

SPECIFICATIONS

- **Cutting Rate:** Up to 150 cuts per minute. Rate is governed by air pressure and flow rate.
- **Construction:** Aluminum anodized frame, tool steel blades, linear bearings.
- **Power Requirements:** 30-90 psi [2 - 6 bar] compressed air (depending on material).

OPTIONS

- SMARTKNIFE™ package
- Blade position sensors
- Custom blade geometry
- Variety of blade material and coatings
- Pneumatic or Spring hold-down clamp



MADE IN THE USA



WARNING:

EQUIPMENT MUST BE GUARDED IN ACCORDANCE WITH ALL FEDERAL, STATE, AND LOCAL REQUIREMENTS



visit us online!



CUSTOM FEEDING & CUTTING SOLUTIONS

26 Just Road, Fairfield, NJ, 07004 | 973-439-1428 | azcocorp.com