

Nordfab eCONO™ Shaker Dust Collectors

eCONO SERIES

The eCONO is available in 5 models and all have features that normally are only available on much more expensive Dust Collectors. They are ideal for the collection of timber and other similar types of dust. All but 1 model has a Porex electric shaker motor that automatically cleans the filter bags every time the unit is turned off. Waste is deposited directly into either 2 to 4 , 180 L plastic bags or feed directly into a waste bin via a rotary valve (eCONO 6000 HRV).



Specifications

Model	eCONO 3000MS	eCONO 3000S	eCONO 4000S	eCONO 4000WB	eCONO 6000S	eCONO 6000WB	eCONO 6000HRV
Fan Motor	3 kW	3 kW	4 kW	4 kW	7.5 kW	7.5 kW	7.5 kW
Air Flow (max)	3000 m ³ /h	3000 m ³ /h	4000 m ³ /h	4000 m ³ /h	6000 m ³ /h	6000 m ³ /h	6000 m ³ /h
Filter Area	13 m ²	13 m ²	13 m ²	13 m ²	30 m ²	30 m ²	30 m ²
Shaker motor power	0.04 kW	0.04 kW	0.04 kW	0.04 kW	0.04 kW	0.04 kW	0.04 kW
Rotary Valve(s)	-	-	-	-	-	-	1 @ 0.75 kW
Height	3231 mm	3133 mm	3133 mm	4025 mm	3743 mm	4632 mm	5148 mm
Width	1848 mm	1848 mm	1990 mm	1990 mm	2103mm	2103mm	3428 mm
Depth	757 mm	757 mm	757 mm	757 mm	1180 mm	1180 mm	1200 mm
Collection Bags	2 @ 500 mm dia x 1500 mm high	2 @ 500 mm dia x 1500 mm high	2 @ 500 mm dia x 1500 mm high	-	4 @ 500 mm dia x 1500 mm high	-	-
Bin Size	-	-	-	240 L Wheelie Bin	-	240 L Wheelie Bin	Up to 3 m ³

Important note: Fires and dust explosions can be caused by various ignition sources including sparks and optimum dust concentrations etc. We recommend fitting dust collectors with explosion vents and locating them outside of buildings to reduce the risk of damage to property and personnel in the event of an explosion or fire.

Nordfab eCONO™ Shaker Dust Collectors

eCONO™ 3000S 3 kW

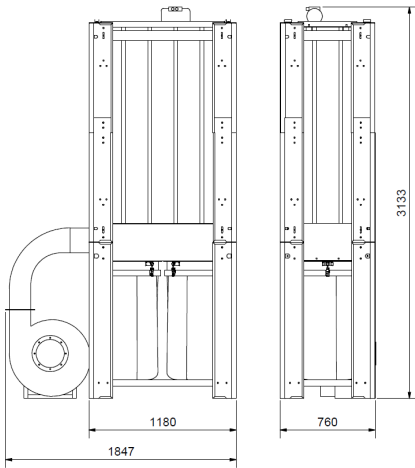

- Compact design
- Powerful 3 kW materials handling fan
- Shaker motor for filter cleaning
- Durable Polyester needlefelt filter bags with large openings for easy dust release
- Large plastic dust bags with retainer collars
- Start-stop controls for the fan
- Automatic timer switch for the shaker motor
- Ideal for timber joinery workshops
- Supplied in kit form

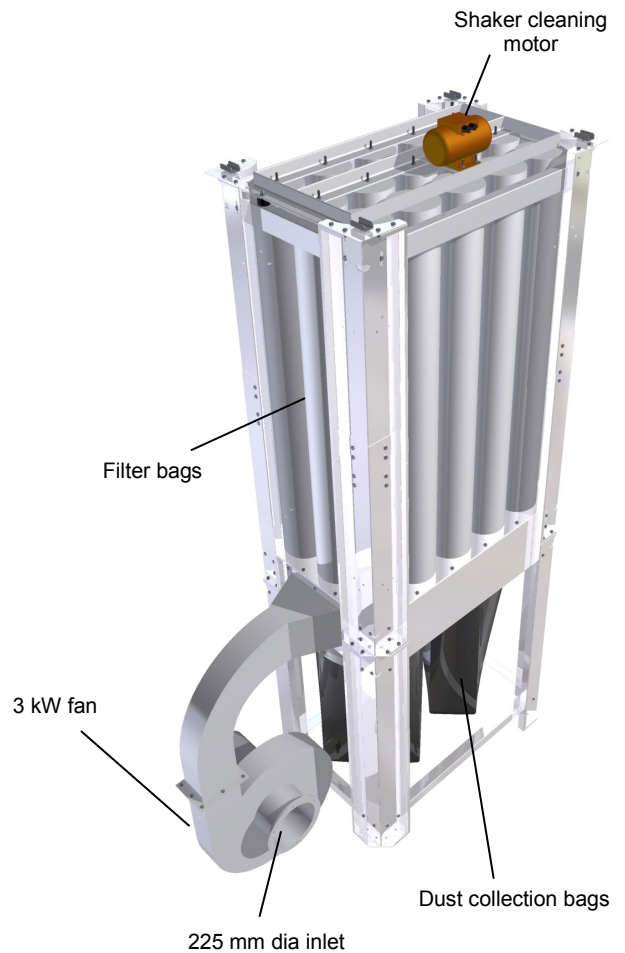

Specifications

Model	eCONO™ 3000S 3 kW
Type	Shaker
Capacity	3,000 m ³ /h @ 2400 Pa (static)
Overall Dimensions	~760 x 1,848 x 3,133 mm high
Inlet Diameter	1 x 225 mm dia
Filters	15 m ² , Cylindrical bag, Antistatic Polyester needlefelt 550 g/m ²
Control panel	Stop/start, D.O.L. fan contactor
Dust bag capacity	2 x 185 L
Motor	3 kW, 2900 rpm, 5.6 A
Construction Material	Galvanised sheet metal
Sound levels	Fan 85 dBA @ 1 m Optional silencer: reduce by 8 dBA Optional acoustic box: reduce by 8 dBA

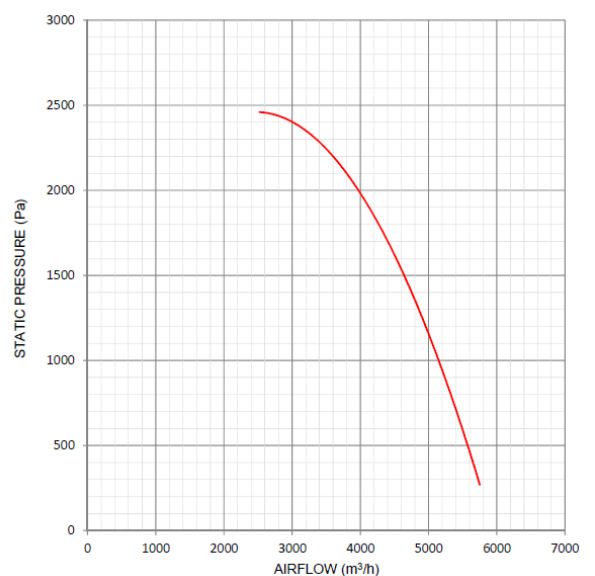

Supplied as flat-pack. Assembly and electrical wiring excluded.

Nordfab eCONO™ Shaker Dust Collectors

eCONO™ 4000S 4 kW

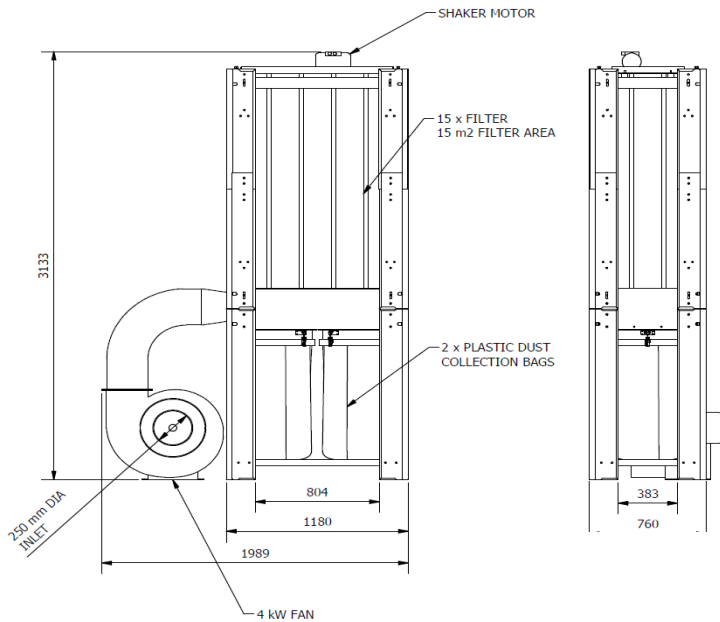

- Compact design
- Powerful 4 kW fan
- Shaker motor for filter cleaning
- Durable Polyester needlefelt filter bags with large openings for easy dust release

- Large plastic dust bags with retainer collars
- Start-stop controls for the fan
- Manual timer switch for the shaker motor
- Ideal for timber joinery workshops
- Supplied in kit form

Specifications

Model	eCONO™ 4000S 4 kW
Type	Shaker
Capacity	4,000 m ³ /h @ 2400 Pa (static)
Overall Dimensions	~760 x 1,990 x 3,133 mm high
Inlet Diameter	1 x 250 mm dia
Filters	15 m ² , Cylindrical bag, Antistatic Polyester needlefelt 550 g/m ²
Control panel	Stop/start, D.O.L. fan contactor
Dust bag capacity	2 x 185 L
Motor	4 kW, 2900 rpm, 7.3 A
Construction Material	Galvanised sheet metal
Sound levels	Fan 85 dBA @ 1 m Optional silencer: reduce by 8 dBA Optional acoustic box: reduce by 8 dBA

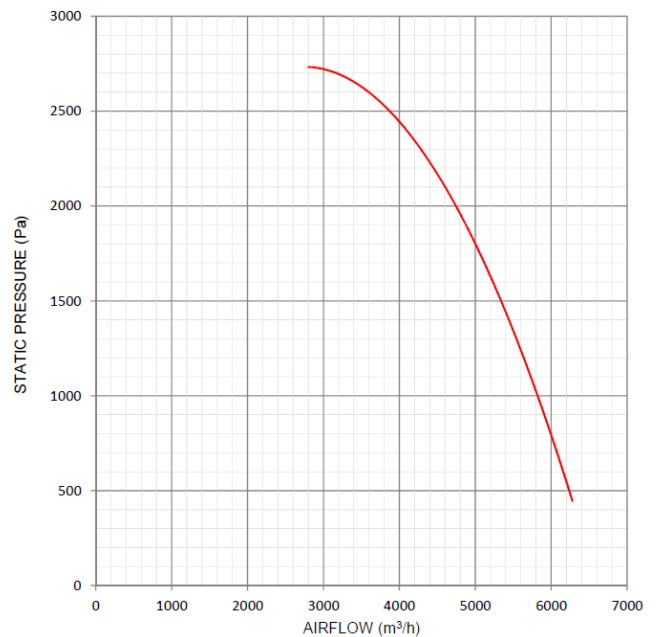

Supplied as flat-pack. Assembly and electrical wiring excluded.

Nordfab eCONO™ Shaker Dust Collectors

eCONO™ 4000WB 4 kW

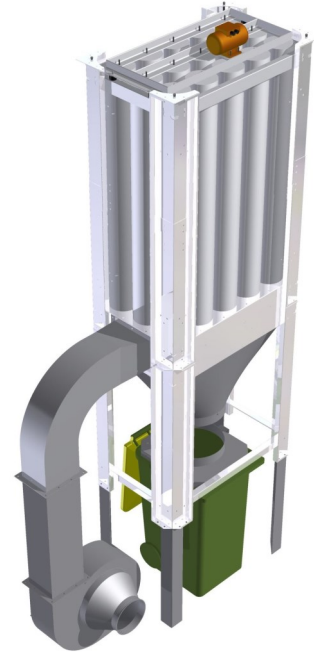
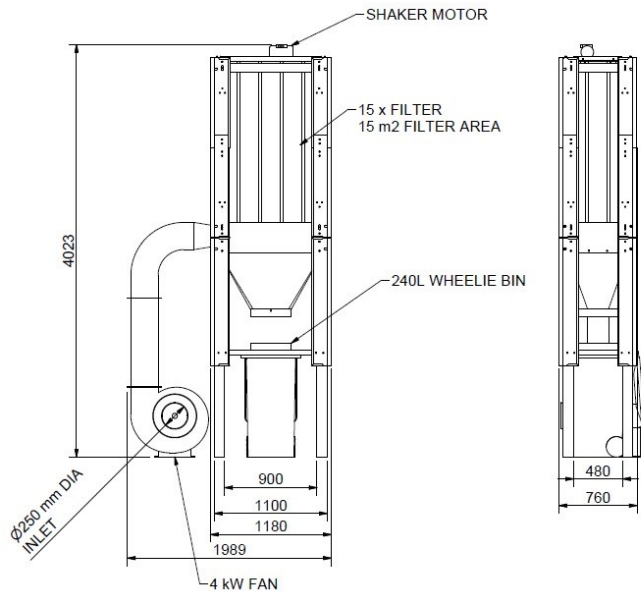

- Compact design
- Powerful 4 kW fan
- Shaker motor for filter cleaning
- Durable Polyester needlefelt filter bags with large openings for easy dust release

- Adapted for 240L wheelie bins
- Start-stop controls for the fan
- Manual timer switch for the shaker motor
- Ideal for timber joinery workshops
- Supplied in kit form

Specifications

Model	eCONO™ 4000WB 4 kW
Type	Shaker
Capacity	4,000 m ³ /h @ 2400 Pa (static)
Overall Dimensions	~760 x 1,990 x 4023 mm high
Inlet Diameter	1 x 250 mm dia
Filters	15 m ² , Cylindrical bag, Antistatic Polyester needlefelt 550 g/m ²
Control panel	Stop/start, D.O.L. fan contactor
Wheelie bin capacity	240L
Motor	4 kW, 2900 rpm, 7.3 A
Construction Material	Galvanised sheet metal
Sound levels	Fan 85 dBA @ 1 m Optional silencer: reduce by 8 dBA Optional acoustic box: reduce by 8 dBA

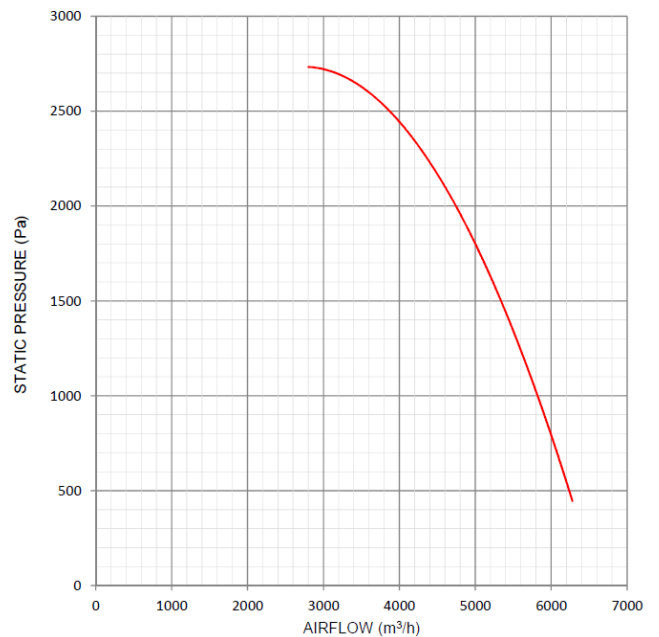

Supplied as flat-pack. Assembly and electrical wiring excluded.

Nordfab eCONO™ Shaker Dust Collectors

eCONO™ 6000S 7.5 kW

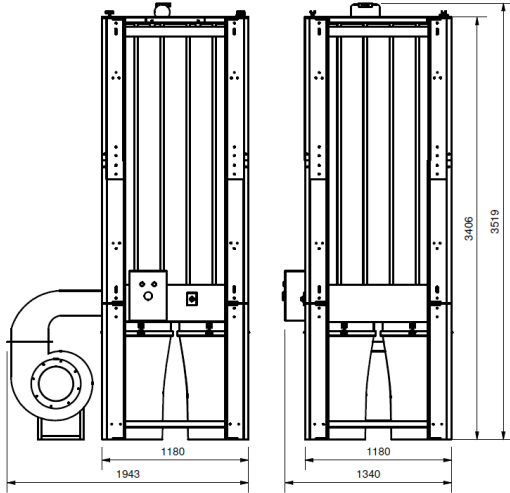

- Compact design
- Powerful 7.5 kW materials handling fan
- Shaker motor for filter cleaning
- Durable Polyester needlefelt filter bags with large openings for easy dust release
- Large plastic dust bags with retainer collars
- Start-stop controls for the fan
- Manual timer switch for the shaker motor
- Ideal for timber joinery workshops
- Supplied in kit form

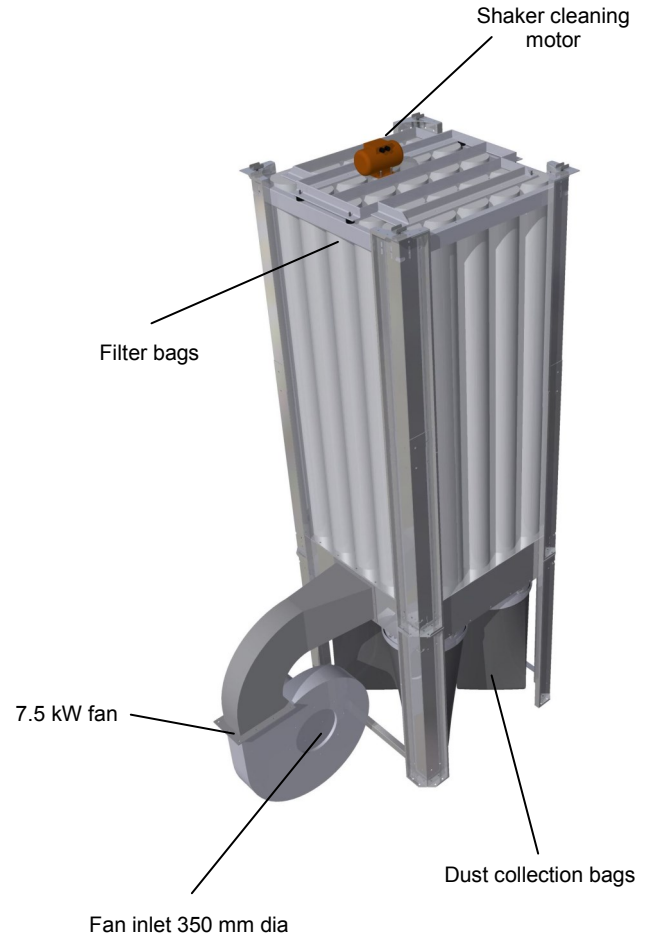

Fan inlet 350 mm dia

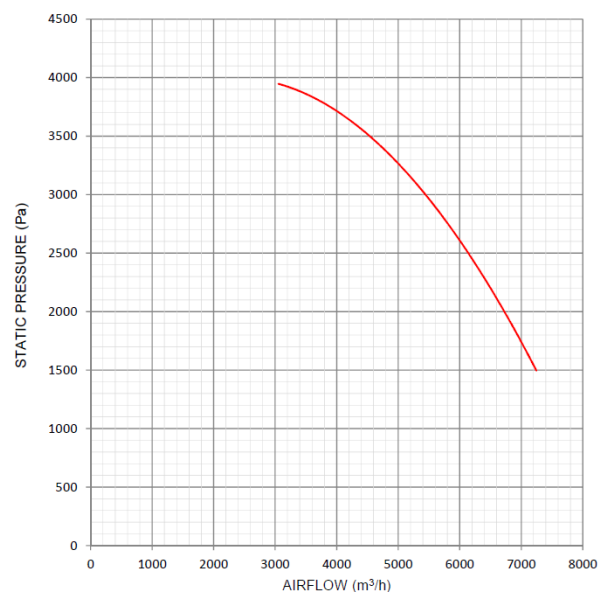

Specifications

Model	eCONO™ 6000S 7.5 kW
Type	Shaker
Capacity	6,000 m ³ /h @ 2500 Pa (static)
Overall Dimensions	~1,180 x 1,180 x 3,519 mm high
Inlet Diameter	1 x 350 mm dia
Filters	30 m ² , Cylindrical bag, Antistatic Polyester needlefelt 550 g/m ²
Control panel	Stop/start, Star-Delta fan contactor
Dust bag capacity	4 x 180 L
Motor	7.5 kW, 2900 rpm, 13.4 A
Construction Material	Mild steel, Galvanised and Powdercoated
Sound levels	Fan 85 dBA @ 1 m Optional silencer: reduce by 8 dBA Optional acoustic box: reduce by 8 dBA

Supplied as flat-pack. Assembly and electrical wiring excluded.